



CAMPING COOKING SET

GB
CAMPING COOKING SET
Instructions for use

CZ
KEMPINKOVÁ SADA NA VAŘENÍ
Návod k použití

SK
KEMPINGOVÁ SÚPRAVA NA
VAŘENIE
Navod na používanie

DE AT CH
CAMPING-KOCHSET
Gebrauchsanweisung

IAN 447955_2307

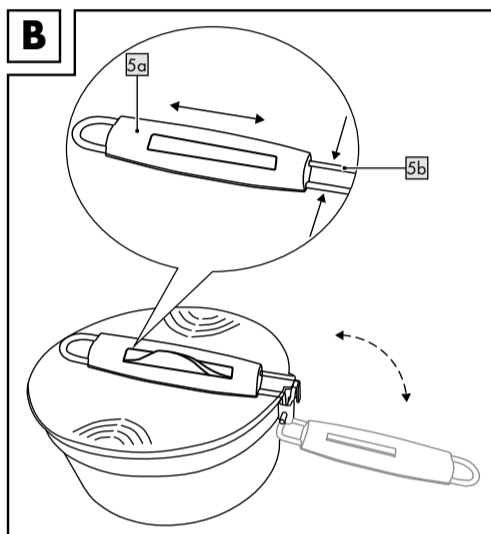
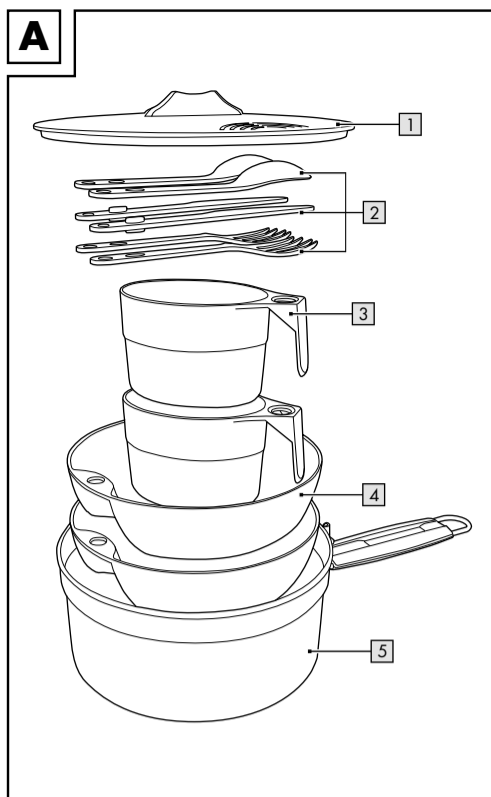

Congratulations!
You have chosen to purchase a high-quality product. Familiarise yourself with the product before using it for the first time.

Read the following instructions for use carefully.

Use the product only as described and only for the given areas of application. Store these instructions for use carefully. When passing the product on to third parties, please also hand over all accompanying documents.

Package contents (Fig. A)

- 1 x lid (1)
- 2 x cutlery set, 3-part (2)
- 2 x cup (3)
- 2 x plate (4)
- 1 x pot with handle (5)
- 1 x instructions for use

Technical data

Camping pot volume: approx. 1600ml
Bowl/plate volume approx. 500ml each
Mug volume approx. 230ml each

Date of manufacture (month/year):
11/2023

Intended use

This product is for private use while camping and is not intended for commercial use. The product is not suitable for deep frying. The pot is suitable for all standard outdoor cooking areas (wood, gas and induction).

The product is not intended for use in the dishwasher! The product is not intended for use in the oven. *The plastic part of the product is heat-resistant up to 100 °C.

- food safe
- not microwave-safe
- not dishwasher-safe
- * temperature resistant up to 100 °C

! Safety information

Important: read these instructions for use carefully and keep them in a safe place!

! Life-threatening hazard!

- Never leave children unattended with the packaging materials. There is a risk of suffocation!

! Risk of injury!

- The product is not break-proof. Do not use the product if it is damaged.
- Check the product for damage or wear before each use. Only use the product if it is in perfect condition!
- Please mind your fingers when assembling the product. There is a risk of injury from crushing.
- The product can become very hot when being used. Use oven gloves.
- Use the pot without a lid when cooking or frying!
- Do not use the cutlery for cooking or frying.
- Exercise caution around hot oil or grease! Do not carry the product if it contains hot oil or grease.
- Do not overheat the product. There is a risk of fire.
- Do not leave the cooking area unattended.
- Do not extinguish flaming grease with water, but instead smother the flames with a blanket or use a fire extinguisher.
- Do not quench the product with cold water.
- Do not heat the product up when it is empty.

! Preventing damage to the product!

- Keep the plastic covering of the handle as far away from the side of the pot as possible when boiling or frying. The plastic handle may melt.

Use (Fig. B)

The product is supplied assembled. To remove the contents from the pot, proceed as follows:

1. Slide the insulation (5a) of the handle out as far as it will go.
2. Press the handle together at the sides (5b).
3. Fold the handle over as shown in Fig. B and slide the insulation back onto the handle.
4. Remove the contents.

Pot

- For optimum energy utilisation, select the cooking area according to the size of the base of the product and place the product in the centre of the cooking area.
- A humming sound may be heard when cooking on induction hobs. This sound is caused by the technology and is not a sign of a defect in your induction hob or the product. This does not affect cooking performance.
- Place the product on a hob that is as big as or smaller than the base of the product. Place the product in the centre of the induction hob.
- Use the lid (1) as a sieve to drain water from the pot.

Note: use oven gloves to pour out hot liquids. The gloves may become hot and wet if carelessly used!
• Use the handle on the pot to close the product using the lid.

Note: do not use any sharp objects on the surface of the pot (5) and do not scratch or cut the surface.

Cutlery

Put the cutlery together when not using it. The knife must be between the spoon and fork.

Closing the pot

1. Let the pot cool down, place the plate, cup (to the side) and the cutlery in the pot and put the lid on the pot.
- Note:** when closing the product, make sure that the bulge on the lid points towards the handle.
2. Slide the insulation (5a) of the handle out as far as it will go.
3. Press the handle together at the sides (5b).
4. Fold the handle over in the direction of the lid and slide the insulation back onto the handle.
5. Position the handle insulation in the centre of the lid to close the product.

Storage, cleaning

The product must be thoroughly cleaned before initial use. When not in use, always store the product clean and dry at room temperature. Clean only with water and a gentle detergent and wipe dry afterwards with a cloth. Use only soft sponges or similar for cleaning. Otherwise, you may damage the surface. **IMPORTANT!** Never clean the product with harsh cleaning agents.

Disposal

Dispose of the product and packaging materials in accordance with current local regulations. Store the packaging materials (foil bags, for example) out of the reach of children. For further information about disposal of the product no longer needed, contact your local council. Dispose of the product and the packaging in an environmentally friendly manner.

The Recycling Code distinguishes different materials to be returned for recycling. The Code consists of the recycling symbol for the recycling process and a number that identifies the material.

Notes on the guarantee and service handling

The product was produced with great care and under continuous quality control. DELTA-SPORT HANDELSKONTOR GmbH gives private end customers a three-year guarantee on this product from the date of purchase (guarantee period) in accordance with the following provisions. The guarantee is only valid for material and manufacturing defects. The guarantee does not cover parts that are subject to normal wear and tear and that are thus considered wear parts (e.g. batteries) and it does not cover fragile parts such as switches or parts that are made of glass.

Claims under this guarantee are excluded if the product has been used incorrectly, improperly, or contrary to the intended purpose, or if the provisions in the instructions for use were not observed, unless the end customer proves that a material or manufacturing defect exists that was not caused by one of the aforementioned circumstances.

Claims under the guarantee can only be made within the guarantee period by presenting the original sales receipt. Please therefore keep the original sales receipt. The guarantee period is not extended by any repairs carried out under the guarantee, under statutory guarantees, or as a gesture of goodwill. This also applies to replaced and repaired parts.



PDF ONLINE
www.lidl-service.com

If you wish to make a claim please first contact the service hotline mentioned below or contact us by e-mail. If there is a guarantee case, then the product will be repaired or replaced free of charge to you or the purchase price will be refunded, depending on our choice. There are no further rights from the guarantee. Your legal rights, in particular guarantee claims against the respective seller, are not limited by this guarantee.

IAN: 447955_2307

GB Service Great Britain
Tel.: 0800 404 7657
E-Mail: deltasport@lidl.co.uk

Srdečně blahopřejeme!

Svým nákupem jste se rozhodli pro kvalitní výrobek. Před prvním použitím se prosím seznamte s tímto výrobkem.

Pozorně si přečtěte následující návod k použití.

Použijte tento výrobek pouze tak, jak je popsáno, a pro uvedené účely. Ušchováte si tento návod k použití pro budoucí použití. Pokud výrobek předáte třetí osobě, předejte jí i veškerou dokumentaci.

Obsah balení (obr. A)

- 1 x poklice (1)
- 2 x sada příborů, 3dílná (2)
- 2 x hrnek (3)
- 2 x talíř (4)
- 1 x hrnec s rukojetí (5)
- 1 x návod k použití

Technické údaje

Objem kempingového hrnce: cca 1 600 ml
Objem misky/talíře cca 500 ml
Objem hrnku cca 230 ml

Datum výroby (měsíc/rok):
11/2023

Použití dle určení

Výrobek je určen pro soukromé účely na kempování a není vhodný pro komerční využití. Výrobek není vhodný pro fritování. Hrnec je vhodný pro všechny standardní venkovní varné plochy (dřevo, plyn a indukce).

Výrobek není určen do myčky nádobí! Výrobek není určen do pečicí trouby.

*Plastové díly výrobku jsou odolné vůči teplotám do 100 °C.

- vhodné pro potraviny
- nevhodné do pečicí trouby
- nevhodné do myčky nádobí
- * teplotní odolnost do 100 °C

! Bezpečnostní pokyny

Důležité: Přečtěte si pozorně návod k použití a bezpodmínečně si jej uschovejte!

! Nebezpečí ohrožení života!

- Nenechávejte děti nikdy bez dozoru s balícím materiálem. Nebezpečí udušení!

! Nebezpečí poranění!

- Výrobek není nerozbitný. Nepoužívejte výrobek, pokud je poškozený.
- Před každým použitím zkontrolujte, zda není výrobek poškozený nebo opoříbovaný. Tento výrobek se smí používat pouze v bezvadném stavu!
- Při sestavování výrobku si dávejte zejména pozor na prsty. Nebezpečí poranění přiskřípnutím.
- Výrobek může být při použití velmi horký. Používejte kuchyňské chňapky.
- Nepoužívejte hrnec při vaření nebo pečení bez poklice!
- Příbory nepoužívejte k vaření nebo pečení.
- Pozor při horkém oleji nebo tuku! Nepřeházejte výrobek s horkým olejem nebo tukem.
- Nepřehívejte výrobek. Hrozí nebezpečí požáru.
- Nenechávejte místo vaření bez dohledu.
- Hořící tuk nikdy nehaste vodou, ale plameny uduste dekou nebo použijte hasicí přístroj.
- Neprovádějte šokové ochlazení výrobku studenou vodou.
- Neohřívajte výrobek bez obsahu.

! Zamezení věcným škodám!

- Při vaření nebo smažení držte plastový kryt rukojetí co nejdále od stěny hrnce. Plastová rukojeť se může tavit.

Použití (obr. B)

Výrobek je dodáván s obsahem uloženým uvnitř. Pro výjmutí obsahu z hrnce postupujte následovně:

1. Vysuňte izolaci rukojetí (5a) až na doraz.
2. Rukojeť po stranách (5b) stiskněte.
3. Překlopte rukojeť podle obr. B a izolaci opět nasuňte na rukojeť.
4. Vyjměte obsah.

Hrnec

- Pro optimální využití energie vyberte varné místo podle velikosti dna výrobku a výrobek umístěte do středu varné plochy.
 - Při vaření na indukčních varných plochách se může objevit bzučivý zvuk. Tento zvuk je technicky podmíněný a není známkou závady indukční varné plochy ani výrobku. Nijak neovlivňuje výkon vaření.
 - Výrobek postavte na varnou plochu, která je stejně velká nebo menší než dno výrobku. Umístěte výrobek na střed indukční plochy.
 - Pro slití vody z hrnce použijte poklici (1) jako sítko.
- Upozornění:** K rozlívání horkých kapalin používejte chňapky. Při neopatrném použití může dojít k promočení a zahřátí rukavic!
• Pro uzavření výrobku poklicí použijte rukojeť na hrnci.

Upozornění: Nepoužívejte na povrch hrnce (5) žádné ostré předměty a neškrábejte nebo nekrájejte na povrchu.

Příbor

Když příbory nepoužíváte, složte je do sebe. Nůž se přitom musí nacházet mezi lžící a vidličkou.

Zavření hrnce

1. Nechte hrnec vychladnout, vložte do něj talíře, šálky (na stranu) a příbory a hrnec přiklopte poklicí.
- Upozornění:** Při uzavření výrobku dbejte na to, aby vykrojení na poklici směřovalo k rukojeti.
2. Vysuňte izolaci rukojetí (5a) až na doraz.
3. Rukojeť po stranách (5b) stiskněte.
4. Sklopte rukojeť směrem k poklici a izolaci opět nasuňte na rukojeť.
5. Izolaci rukojetí vycentrujte na poklici, čímž výrobek uzavřete.

Uskladnění, čištění

Výrobek před prvním použitím důkladně vyčistěte. Pokud výrobek nepoužíváte, skladujte jej vždy suchý a čistý při pokojové teplotě. Čistěte pouze vodou a jemným čisticím prostředkem a následně otřete do sucha hadříkem. K čištění používejte jen měkké houbičky nebo podobně. Povrch výrobku by se mohl poškodit. **DŮLEŽITÉ!** K čištění nikdy nepoužívejte agresivní čisticí prostředky.

Pokyny k likvidaci

Výrobek a obalové materiály likvidujte podle aktuálních místních předpisů. Uchovávejte obalové materiály (jako např. fóliové sáčky) nedostupné pro děti. O možnostech likvidace vysloužilého výrobku se informujte u Vaší obecní nebo městské správy. Výrobek a obaly likvidujte ekologicky.

Recyklační kód slouží ke značení různých materiálů pro proces opětovného zhodnocení (recyklace). Kód sestává ze symbolů recyklace, který má odrážet proces zhodnocení, a čísla, které označuje materiál.

Pokyny k záruce a průběhu služby

Výrobek byl vyroben s velkou péčí a za stálé kontroly. DELTA-SPORT HANDELSKONTOR GmbH poskytuje koncovým privátním zákazníkům na tento výrobek tři roky záruky od data nákupu (záruční lhůta) podle následující ustanovení. Záruka se týká pouze vad materiálu a závad ve zpracování. Záruka se nevztahuje na díly, které podléhají běžnému opotřebení, a proto je třeba je považovat za opotřebitelné díly (např. baterie), ani na křehké díly, jako jsou vypínače nebo díly ze skla. Nároky z této záruky jsou vyloučeny, pokud výrobek byl používán neodborně nebo nedovoleným způsobem nebo nikoli v rámci stanoveného účelu určení nebo předpokládaného rozsahu používání nebo nebyla dodržena zadání v návodu k obsluze, ledaže by koncový zákazník prokázal, že existuje vada materiálu nebo došlo k chybě ve zpracování, které nevyplyvají z některé výše uvedených okolností. Nároky ze záruky lze uplatnit pouze v rámci záruční lhůty po předložení originálního pokladního dokladu. Proto si prosím uschovejte originál pokladního dokladu. Doba záruky se neprodlužuje případnými opravami na základě záruky, zákonné záruky nebo kulance. Totéž platí také pro vyměněné a opravené díly.

Při reklamaciích se prosím obračejte na níže uvedenu horkou linku servisu nebo se s námi spojte e-mailem. Pokud se vyskytne případ reklamacie, výrobek Vám – dle naší volby – bezplatně opravíme, vyměníme nebo Vám vrátíme kupní cenu. Další práva ze záruky nevznikají.

Vaše zákonná práva, zejména nároky na zajištění záruky vůči konkrétnímu prodejci, nejsou touto zárukou omezena.

IAN: 447955_2307

- Servis Česko Tel.: 800 143 873 E-Mail: deltasport@lidl.cz

Blahoželáme!

Svojím nákupom ste sa rozhodli pre kvalitný výrobok. Pred prvým použitím sa s výrobkom dôkladne oboznámte.

Pozorne si prečítajte tento návod na používanie.

Výrobok používajte len uvedeným spôsobom a na uvedený účel. Tento návod na používanie si dobre uschovajte. Pri odovzdávaní výrobku tretej osobe odovzdajte s výrobkom aj všetky podklady.

Rozsah dodávky (obr. A)

1 x pokrievka (1)
2 x súprava príborov, 3-dielna (2)
2 x pohár (3)
2 x tanier (4)

1 x hrniec s rukoväťou (5)
1 x návod na používanie

Technické údaje

Užitočný objem kempingového hrnca: cca 1 600 ml

Užitočný objem misky/taniera po cca 500 ml

Užitočný objem hrnčeka po cca 230 ml

Dátum výroby (mesiac/rok): 11/2023

Určené použitie

Tento výrobok je určený na kempovanie na súkromné použitie a nie je určený na komerčné použitie. Tento výrobok nie je vhodný na fritovanie. Hrniec je vhodný na všetky štandardné vonkajšie varné plochy (na drevo, plyn a indukciu).

Výrobok nie je vhodný do umývačky riadu! Výrobok nie je vhodný do rúry.

*Plastové časti výrobku sú odolné proti teplote do 100 °C.

vhodný pre potraviny

nevhodný do rúry

nevhodný do umývačky riadu

* odolný proti teplote do 100 °C

Herzlichen Glückwuschl
Mit Ihrem Kauf haben Sie sich für einen hochwertigen Artikel entschieden. Machen Sie sich vor der ersten Verwendung mit dem Artikel vertraut.

Lesen Sie hierzu aufmerksam die nachfolgende Gebrauchsanweisung.

Benutzen Sie den Artikel nur wie beschrieben und für die angegebenen Einsatzbereiche. Bewahren Sie diese Gebrauchsanweisung gut auf. Händigen Sie alle Unterlagen bei Weitergabe des Artikels an Dritte ebenfalls mit aus.

Lieferumfang (Abb. A)

1 x Deckel (1)
2 x Besteck-Set, 3-teilig (2)
2 x Becher (3)
2 x Teller (4)

1 x Topf mit Griff (5)

1 x Gebrauchsanweisung

Technische Daten

Nutzvolumen Campingtopf: ca. 1.600 ml

Nutzvolumen Schüssel/Teller je ca. 500 ml

Nutzvolumen Tasse je ca. 230 ml

Herstellungsdatum (Monat/Jahr): 11/2023

Bestimmungsgemäße Verwendung

Dieser Artikel ist für den Campingbereich für den privaten Gebrauch und nicht für den gewerblichen Gebrauch bestimmt. Der Artikel ist nicht zum Frittieren geeignet. Der Topf ist für alle gängigen Outdoor-Kochplätze (Holz, Gas und Induktion) geeignet. Der Artikel ist nicht für den Geschirrspüler geeignet! Der Artikel ist nicht für den Backofen geeignet. *Die Kunststoffteile des Artikels sind bis 100 °C temperaturbeständig.

lebensmittelgeeignet

nicht backofengeeignet

nicht spülmaschinengeeignet