



**STORAGE CABINET / AUFBEWAHRUNGSSCHRANK /  
CABINET DE STOCKAGE**

Nr. Art. 5002970

**DE Aufbewahrungsschrank**  
Kurzanleitung

AT

CH

**FR cabinet de stockage**  
Guide de démarrage rapide

**NL Opbergkast**

Korte montage instructies

BE

**FI Säilytyskaappi**  
Lyhyet kokoonpanoohjeet

**PL Szafka do przechowywania**  
Skrócona instrukcja montażu

**GB Storage cabinet**  
Short manual

IE

**LT Sandėliavimo spinta**  
Trumpos surinkimo instrukcijos

**LV Uzglabāšanas skapis**  
Īsas montāžas instrukcijas

**EE Hoiukapp**

Kiirpaigaldusjuhend

**HU Tárolószekrény**  
Rövid összeszerelési utasítások

**CZ Úložná skříň**  
Průvodce rychlou instalací

**SI Omara za shranjevanje**  
Navodila za kratko montažo

**SK Odkladacia skrinka**  
Krátke pokyny na montáž

**DK Opbevaringsskab**  
Korte monteringsinstruktioner

**IT Armadio di stoccaggio**  
Brevi istruzioni di assemblaggio

**ES Armario de almacenamiento**  
Instrucciones de ensamblaje corta

**PT Armário de armazenamento**  
Instruções de montagem curta

**RS Orman za skladištenje**  
Uputstvo za montažu

**GR ντουλάπα αποθήκευσης**  
Οδηγίες σύντομης συναρμολόγησης

**HR Ormar za skladištenje**  
Kratke upute za montažu

**RO Dulap de depozitare**  
Instrucțiuni de asamblare scurtă

**BG шкаф за съхранение**  
Кратки инструкции за сглобяване

**SE Förvaringsskåp**  
Korta monteringsinstruktioner

IAN 437070\_2304

GB MT IE

This information sheet is an integral part of the assembly instructions.  
Store it in a safe place together with the instruction manual.  
If you hand over the product to third parties, please also hand over all documentation to them.  
Before using the product, read the assembly instructions and pay attention to the safety instructions contained therein.

FR BE CH

Cette fiche d'information fait partie intégrante des instructions de montage.  
Rangez-le dans un endroit sûr avec le manuel d'instructions.  
Si vous remettez le produit à des tiers, veuillez également leur remettre toute la documentation.  
Avant d'utiliser le produit, lisez les instructions de montage et faites attention aux consignes de sécurité qu'elles contiennent.

NL BE

Dit informatieblad maakt integraal deel uit van de montagehandleiding.  
Bewaar het samen met de gebruiksaanwijzing op een veilige plaats.  
Als u het product aan derden overhandigt, dient u ook alle documentatie aan hen te overhandigen.  
Lees voor gebruik van het product de montage-instructies en let op de daarin opgenomen veiligheidsinstructies.

DE AT CH

Dieses Merkblatt ist Bestandteil der Montageanleitung.  
Bewahren Sie es zusammen mit der Bedienungsanleitung an einem sicheren Ort auf.  
Wenn Sie das Produkt an Dritte weitergeben, übergeben Sie diesen bitte auch alle Unterlagen.  
Lesen Sie vor Gebrauch des Produkts die Montageanleitung und beachten Sie die darin enthaltenen Sicherheitshinweise.

PL

Niniejsza karta informacyjna jest integralną częścią instrukcji montażu. Przechowuj go w bezpiecznym miejscu wraz z instrukcją obsługi. Jeśli przekazujesz produkt osobom trzecim, przekaz im również całą dokumentację. Przed użyciem produktu zapoznaj się z instrukcją montażu i zwróć uwagę na zawarte w niej wskazówki dotyczące bezpieczeństwa.

ES

Esta hoja de información es parte integrante de las instrucciones de montaje.  
Guárdelo en un lugar seguro junto con el manual de instrucciones.  
Si entrega el producto a terceros, entrégueles también toda la documentación.  
Antes de utilizar el producto, lea las instrucciones de montaje y preste atención a las instrucciones de seguridad contenidas en el mismo.

DK

Dette informationsblad er en integreret del af monteringsvejledningen.  
Opbevar det et sikkert sted sammen med brugsanvisningen.  
Hvis du afleverer produktet til tredjeparter, bedes du også aflevere al dokumentation til dem.  
Før du bruger produktet, skal du læse monteringsvejledningen og være opmærksom på sikkerhedsinstruktionerne deri.

CZ

Tento informační list je nedílnou součástí montážního návodu.  
Uložte jej na bezpečném místě společně s návodem k použití.  
Pokud výrobek předáte třetím osobám, předejte jim také veškerou dokumentaci.  
Před použitím výrobku si přečtěte montážní návod a věnujte pozornost bezpečnostním pokynům v něm obsaženým.

SK

Tento informačný list je neoddeliteľnou súčasťou montážneho návodu.  
Uchovajte ho na bezpečnom mieste spolu s návodom na použitie.  
Ak odovzdáte výrobok tretím osobám, odovzdajte im aj všetku dokumentáciu.  
Pred použitím výrobku si prečítajte montážny návod a dbajte na bezpečnostné pokyny v ňom uvedené.

IT CH MT

Questa scheda informativa è parte integrante delle istruzioni di montaggio.  
Conservarlo in un luogo sicuro insieme al manuale di istruzioni.  
Se si consegna il prodotto a terzi, consegnare anche tutta la documentazione.  
Prima di utilizzare il prodotto, leggere le istruzioni di montaggio e prestare attenzione alle istruzioni di sicurezza in esse contenute.

PT

Esta folha de informações é parte integrante das instruções de montagem.  
Guarde-o em local seguro junto com o manual de instruções.  
Se você entregar o produto a terceiros, entregue também toda a documentação.  
Antes de utilizar o produto, leia as instruções de montagem e preste atenção às instruções de segurança contidas nas mesmas.

SI

Ta informativni list je sestavni del navodil za montažo.  
Shranite ga na varno mesto skupaj z navodili za uporabo.  
Če izdelek predajate tretji osebi, ji izročite tudi vso dokumentacijo.  
Pred uporabo izdelka preberite navodila za montažo in bodite pozorni na varnostna navodila, ki jih vsebujejo.

SE

Detta informationsblad är en integrerad del av monteringsanvisningen.  
Förvara den på ett säkert ställe tillsammans med bruksanvisningen.  
Om du skänker produkten till en tredje part måste du också lämna över all dokumentation till dem.  
Innan du använder produkten, läs monteringsanvisningen och beakta säkerhetsinstruktionerna som finns däri.

FI

Tämä tietolomake on erottamaton osa asennusohjeita.  
Säilytä sitä turvallisessa paikassa käyttöohjeiden kanssa.  
Jos lahjoitat tuotteen kolmannelle osapuolelle, sinun on myös luovutettava kaikki asiakirjat heille.  
Lue kokoamisohjeet ennen tuotteen käyttöä ja huomioi sen sisältämät turvallisuusohjeet.

EE

See teabeleht on monteerimisjuhendi lahutamatu osa.  
Hoidke seda koos kasutusjuhendiga kindlas kohas.  
Kui annate toote üle kolmandale isikule, peate üle andma ka kogu dokumentatsiooni.  
Enne toote kasutamist lugege kokkupanekujuhendit ja pöörake tähelepanu selles sisalduvatele ohutusjuhisteile.

LT

Šis informacinis lapas yra neatskiriama surinkimo instrukcijos dalis.  
Laikykite jį kartu su naudojimo instrukcija saugioje vietoje.  
Jei prekę perduodate trečiajai šaliai, privalote perduoti ir visą dokumentaciją.  
Prieš naudodami gaminį, perskaitykite surinkimo instrukcijas ir atkreipkite dėmesį į joje pateiktas saugos instrukcijas.

GR CY

Αυτό το φύλλο πληροφοριών αποτελεί αναπόσπαστο μέρος των οδηγιών συναρμολόγησης. Φυλάξτε το μαζί με το εγχειρίδιο λειτουργίας σε ασφαλές μέρος. Εάν παραδώσετε το προϊόν σε τρίτο μέρος, πρέπει να παραδώσετε και όλα τα έγγραφα.  
Πριν χρησιμοποιήσετε το προϊόν, διαβάστε τις οδηγίες συναρμολόγησης και δώστε προσοχή στις οδηγίες ασφαλείας που περιέχονται σε αυτές.

HU

Ez az adatlap az összeszerelési útmutató szerves részét képezi.  
Tartsa biztonságos helyen a használati útmutatóval együtt.  
Ha a terméket harmadik félnek adja át, akkor minden dokumentációt is át kell adnia.  
A termék használata előtt olvassa el az összeszerelési útmutatót, és vegye figyelembe az abban található biztonsági utasításokat.

HR

Ovaj informativni list je sastavni dio uputa za montažu.  
Čuvajte ga zajedno s priručnikom za uporabu na sigurnom mjestu.  
Ukoliko proizvod predate trećoj strani, morate predati i svu dokumentaciju.  
Prije uporabe proizvoda pročitajte upute za montažu i obratite pozornost na sigurnosne upute koje se u njima nalaze.

LV

Šī informācijas lapa ir montāžas instrukcijas neatņemama sastāvdaļa.  
Glabājiet to kopā ar lietošanas instrukciju drošā vietā.  
Ja precī nododat trešajai personai, jums ir jānodod arī visa dokumentācija.  
Pirms izstrādājuma lietošanas izlasiet montāžas instrukciju un pievērsiet uzmanību tajā ietvertajiem drošības norādījumiem.

BG

Този информационен лист е неразделна част от инструкциите за монтаж. Съхранявайте го заедно с ръководството за експлоатация на сигурно място. Ако предадете продукта на трета страна, трябва да предадете и цялата документация. Преди да използвате продукта, прочетете инструкциите за монтаж и обърнете внимание на инструкциите за безопасност, съдържащи се в тях.

RO

Această fișă de informații este parte integrantă a instrucțiunilor de asamblare. Păstrați-l împreună cu manualul de utilizare într-un loc sigur. Dacă predați produsul unei terțe părți, trebuie să predați și toată documentația. Înainte de a utiliza produsul, citiți instrucțiunile de asamblare și acordați atenție instrucțiunilor de siguranță conținute în acestea.

RS

Ovaj informativni list je sastavni deo uputstva za montažu.  
Čuvajte ga zajedno sa uputstvom za upotrebu na bezbednom mestu.  
Ako proizvod predate trećem licu, morate predati i svu dokumentaciju.  
Pre upotrebe proizvoda, pročitajte uputstva za sastavljanje i obratite pažnju na bezbednosna uputstva koja se nalaze u njima.

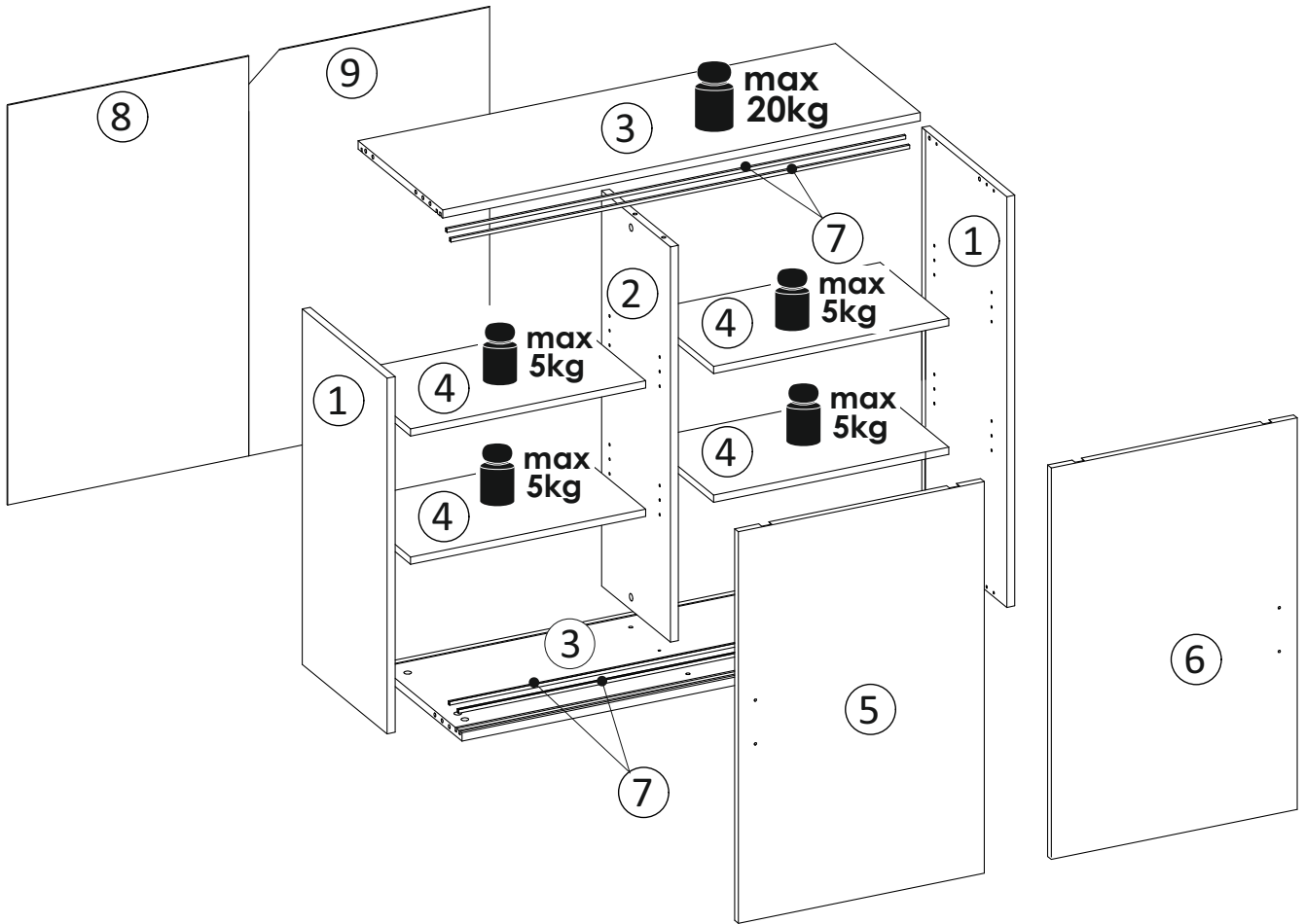

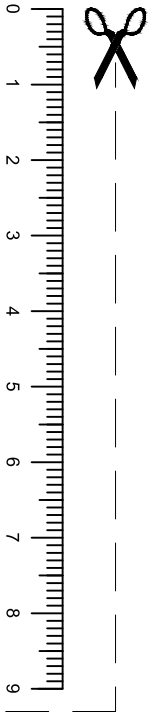

Sie benötigen:	Reikalinga:		
You need:	Tarvitset:		
Potrzebne są:	Nutno mít:		
Vi servono:	Potrebné sú:		
Necesita:	Szükséges:		
Necessita:	Du behøver:		
Benodiggheden:	Trebate:		
Potřebujete:	Необходими са:		
Vous avez besoin de:	Aveți nevoie de:		
Χρειάζονται τα εξής:	Необходими:		
Behövs:	Potrebni su:		

Beschläge / Fittings / Okucia / Raccordi / Herrajes / Ferragens / Beslag / Kovanie / Quincaillerie / Προσαρτήματα επίπλων / Rördelar / Furnitūra / Helat / Kování / Kovania / Vasalatok / Beslag / Oprema / Обков / Fitinguri / Оковки / Okovi

 Ø20 <b>14 x ZMN</b>	 Ø15x12 <b>14 x M1</b>	 Ø3,5x16 <b>1 x W1</b>	 Ø4x30 <b>5 x W16</b>	 Ø3,5x13 <b>8 x W2</b>
 Ø4x16 <b>1 x W5</b>	 4x22 <b>4 x W15</b>	 Ø3x20 <b>5 x W10</b>	 <b>16 x D2</b>	 <b>8 x C1</b>
 77x32x16 <b>1 x BM</b>	 <b>2 x H2</b>	 <b>1 x P9</b>	 <b>5 x C6</b>	 <b>1 x N</b>
 Ø8x30 <b>12 x K2</b>	 <b>5 x E6</b>	 <b>14 x T2</b>	 <b>4 x P5</b>	 <b>4 x P6</b>
 <b>4xS</b>				

Teile / Article / Części / Accessori / Piezas / Peças / Onderdelen / Diely / Éléments / Εξαρτήματα / Delar / Dalys / Osat / Díly / Časti / Alkatrészek / Dele / Dijelovi / Части / Piese / Части / Delovi

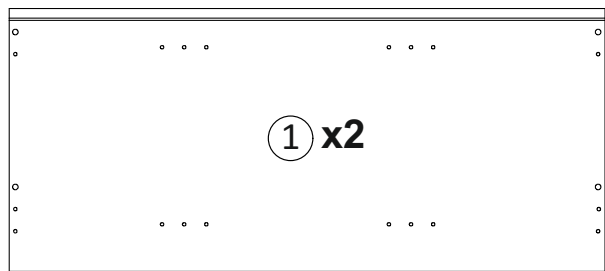

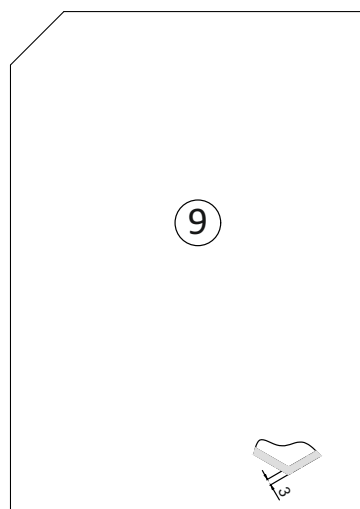
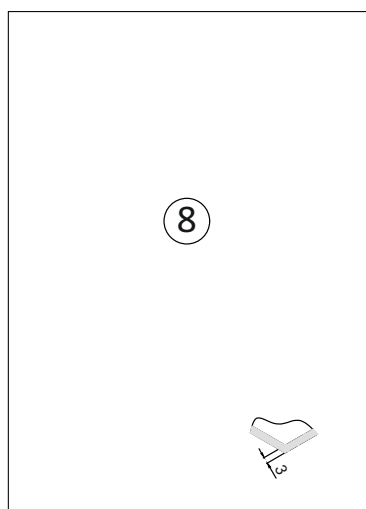
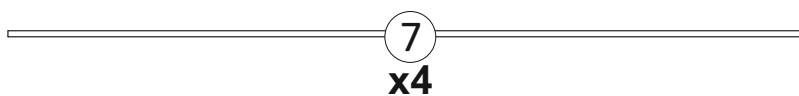
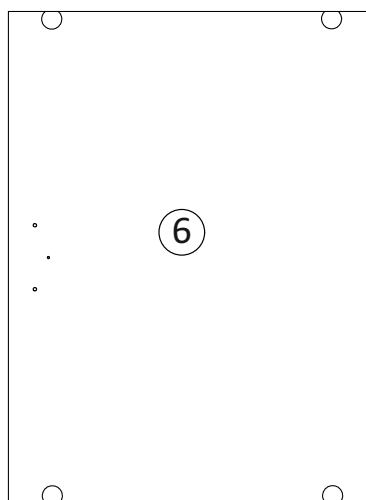
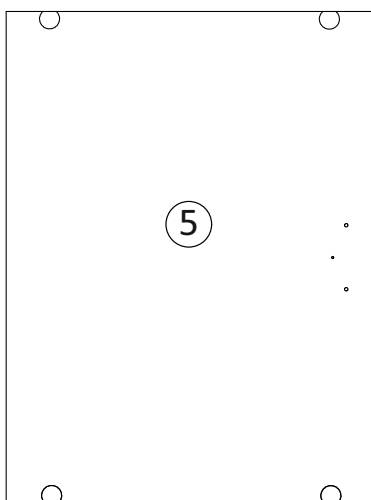
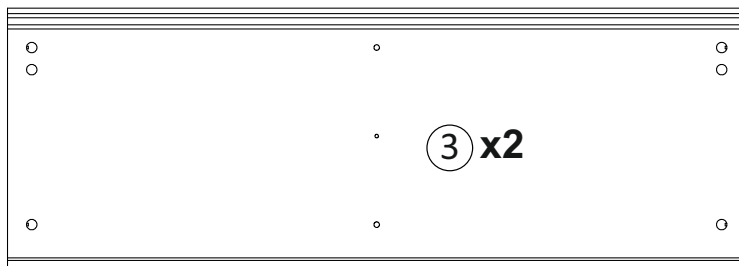
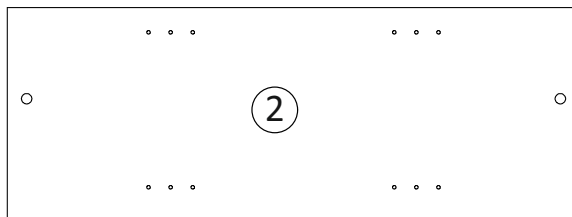
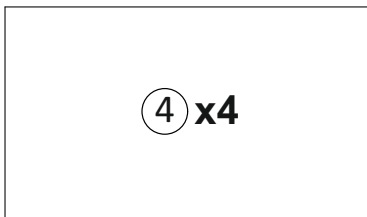

**A**

Ø8x30



8 x K2

Ø15x12



12 x M1

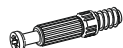

14 x T2



8 x D2

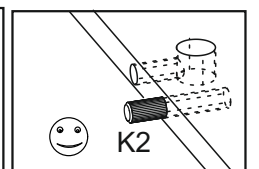
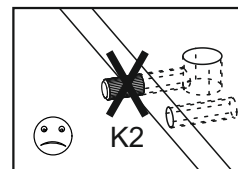
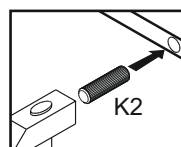
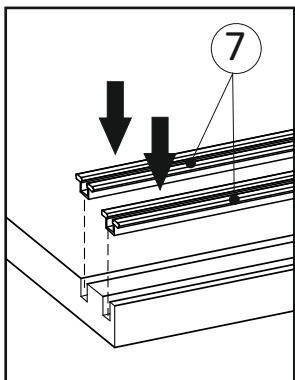
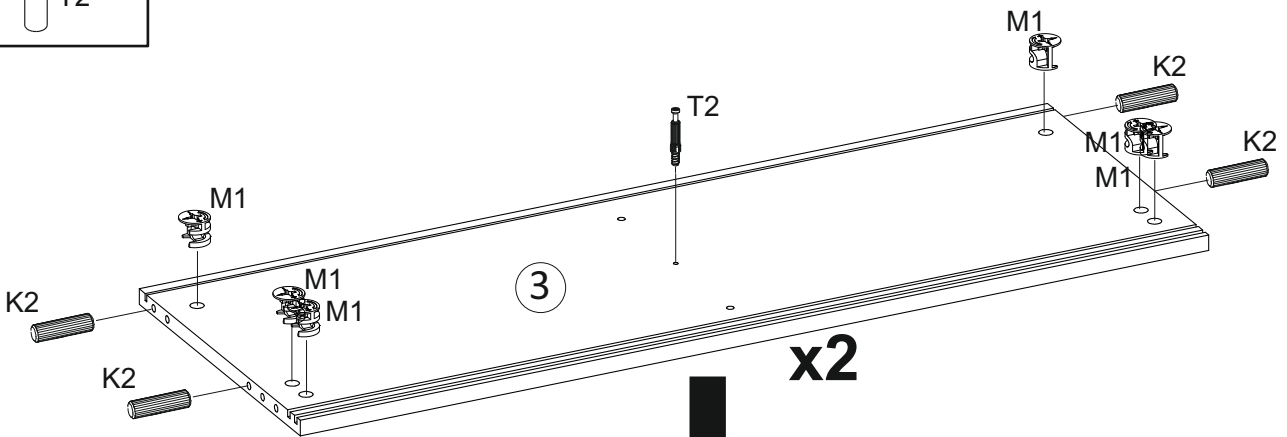
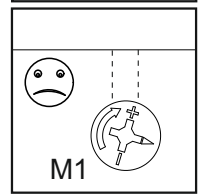
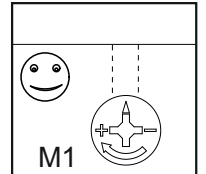
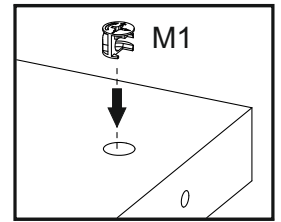
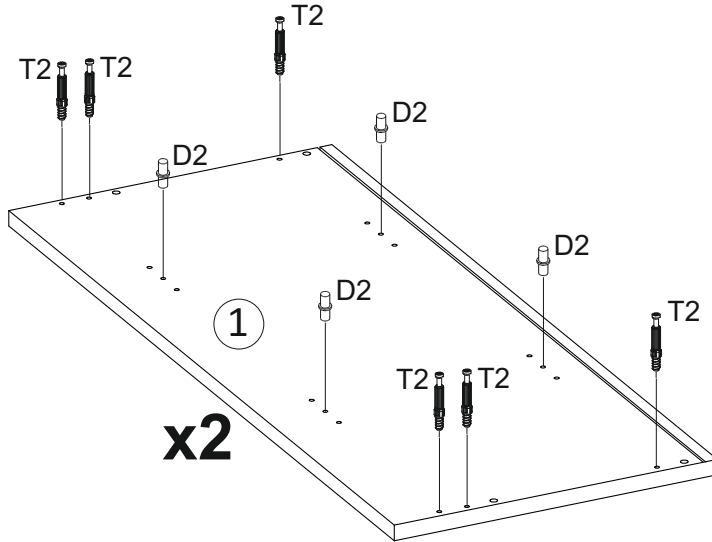
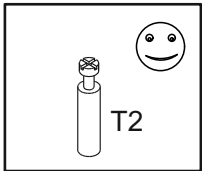
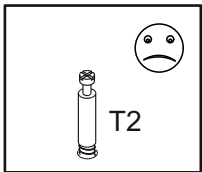
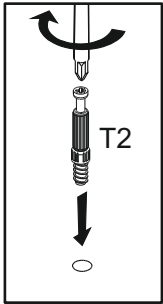
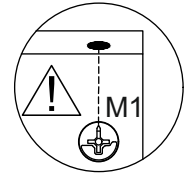



**B**

Ø8x30



4 x K2

Ø15x12



2 x M1

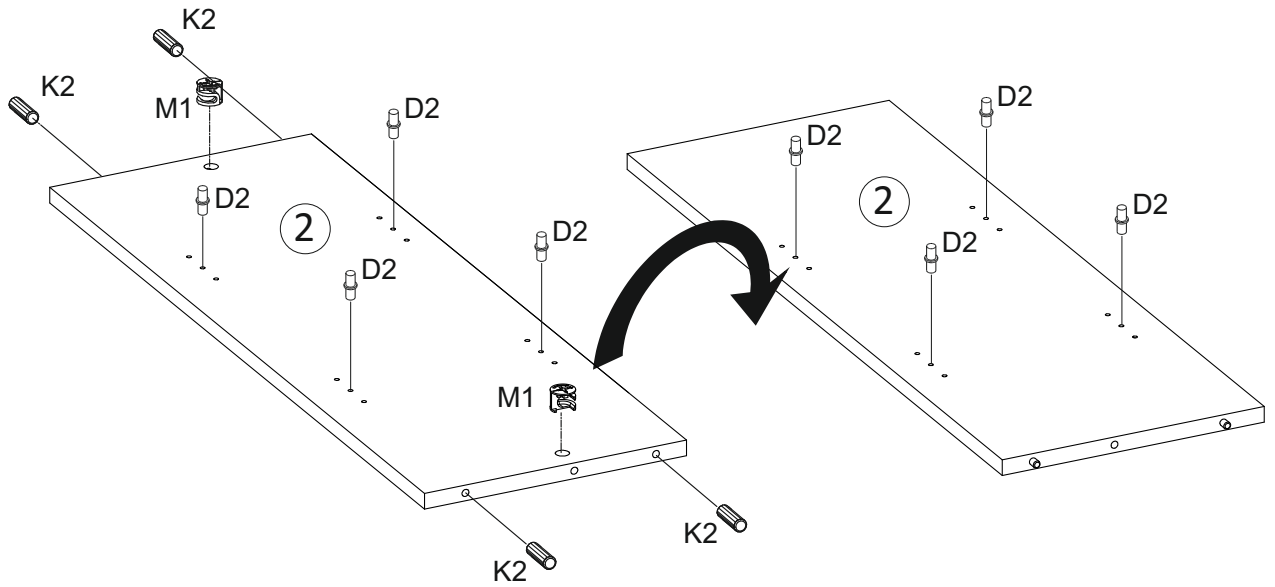

8 x D2

**C**

Ø20



2 x ZMN

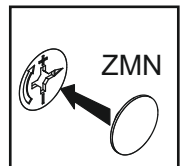
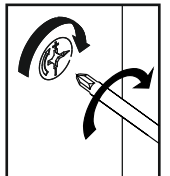
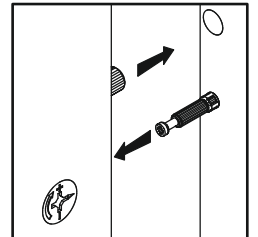
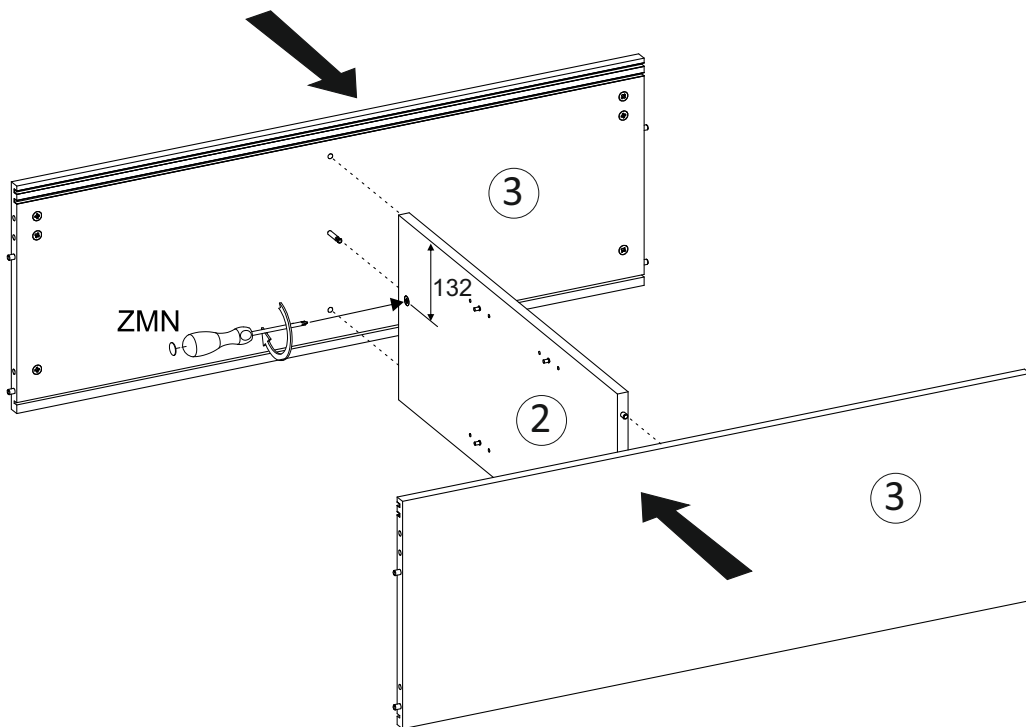

# D

Ø20  
6 x ZMN

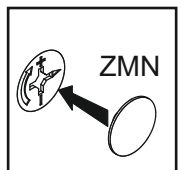
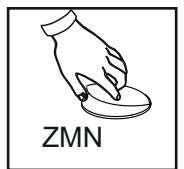
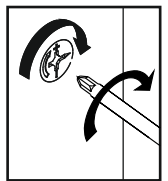
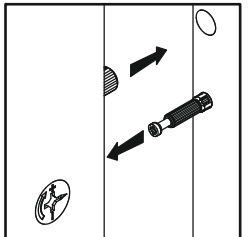
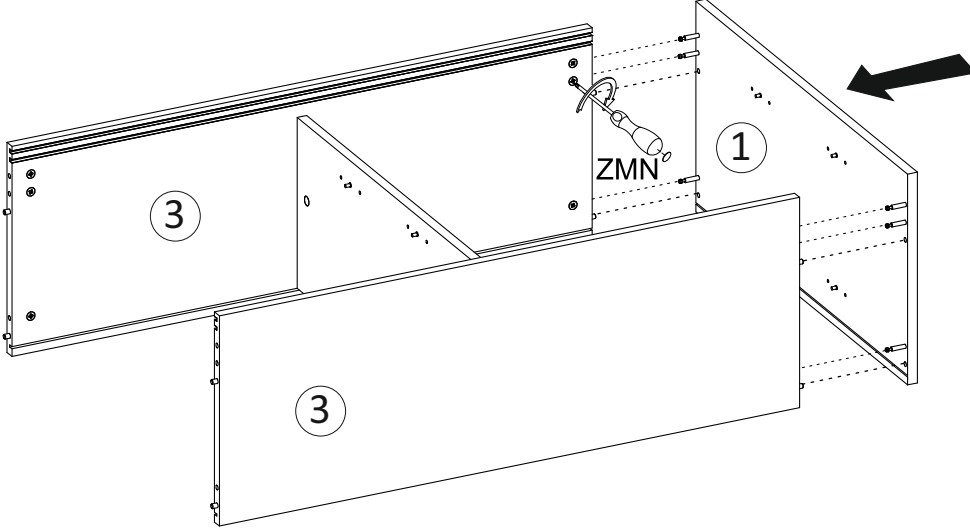

# E

Ø20  
6 x ZMN

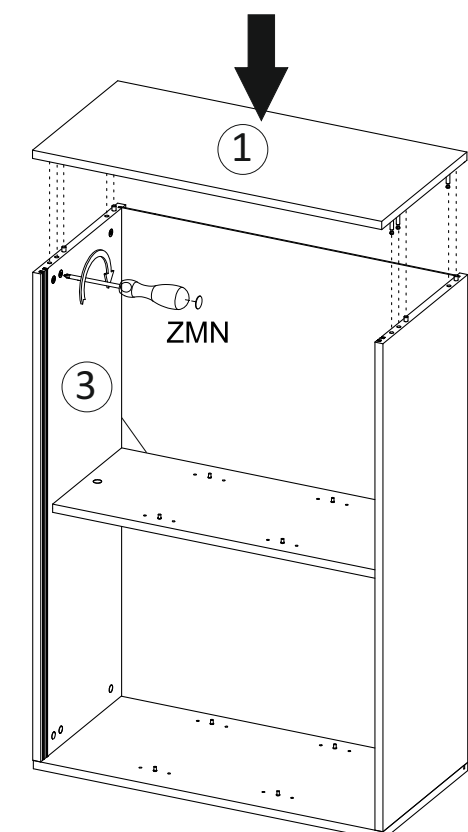
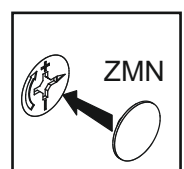
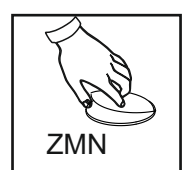
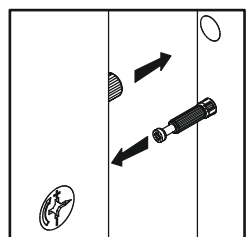
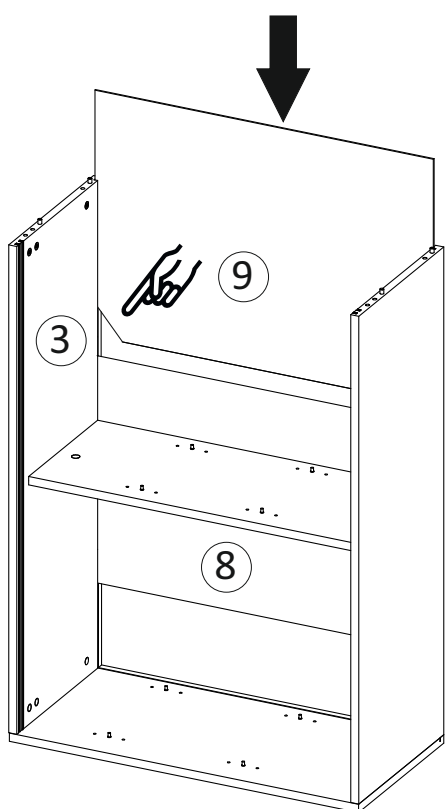

# F

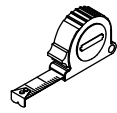
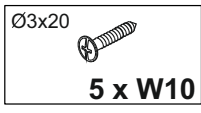
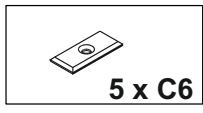
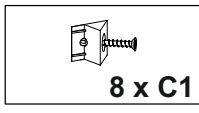

XX=YY≅90°

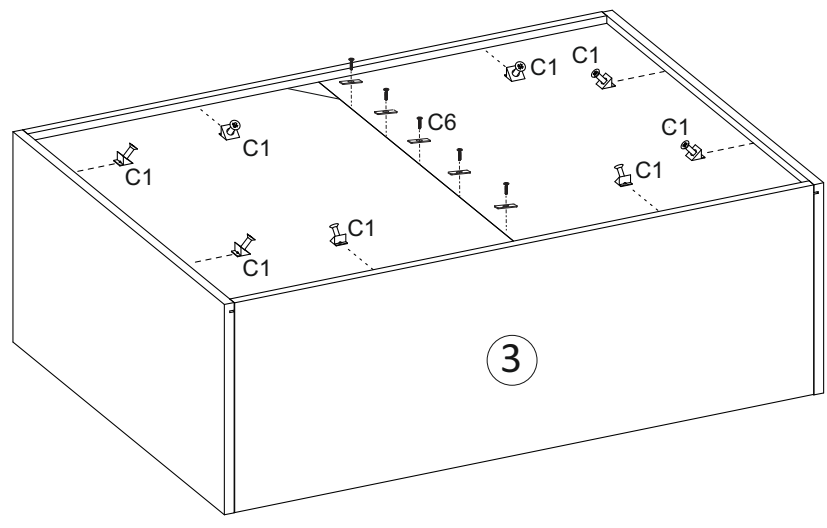
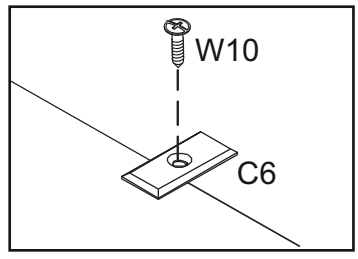
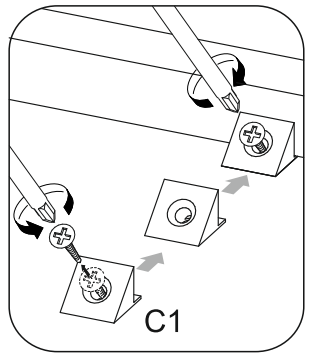
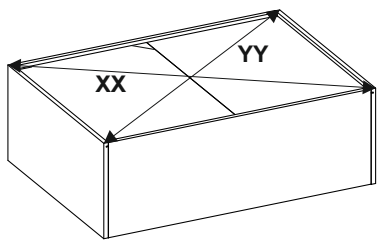

# G

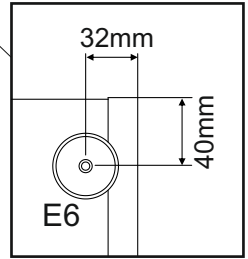
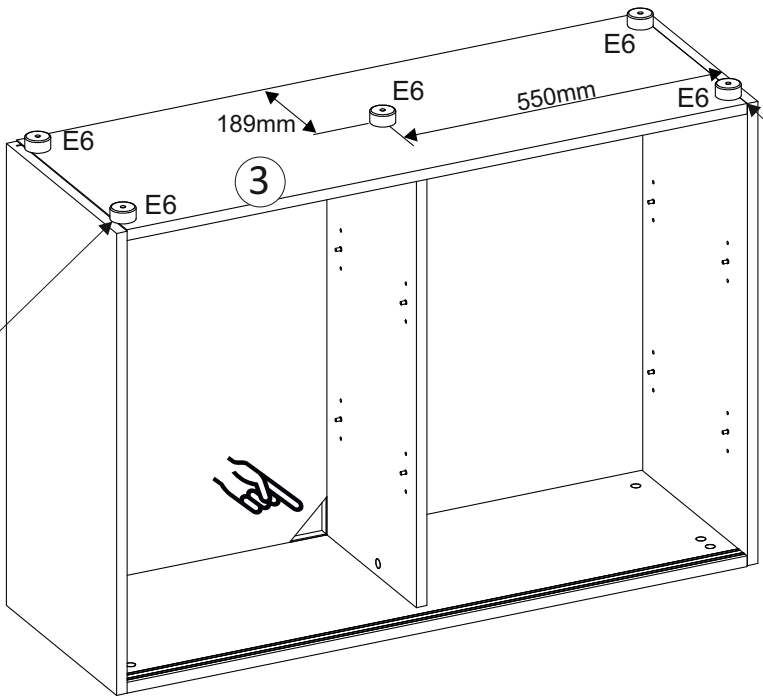
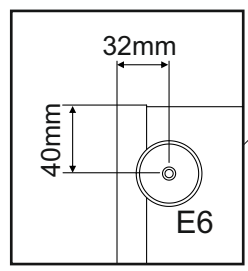
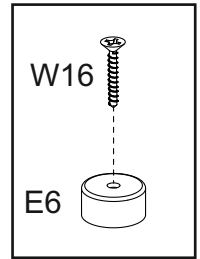
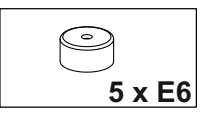
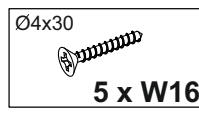

H

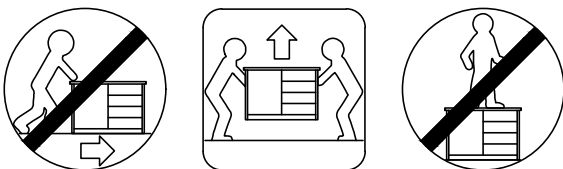
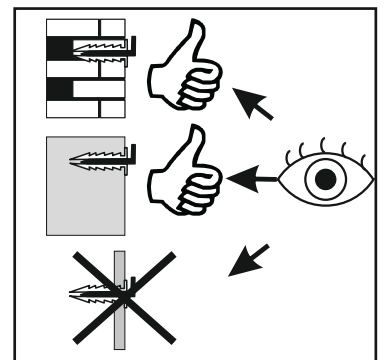
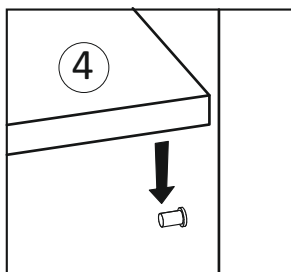
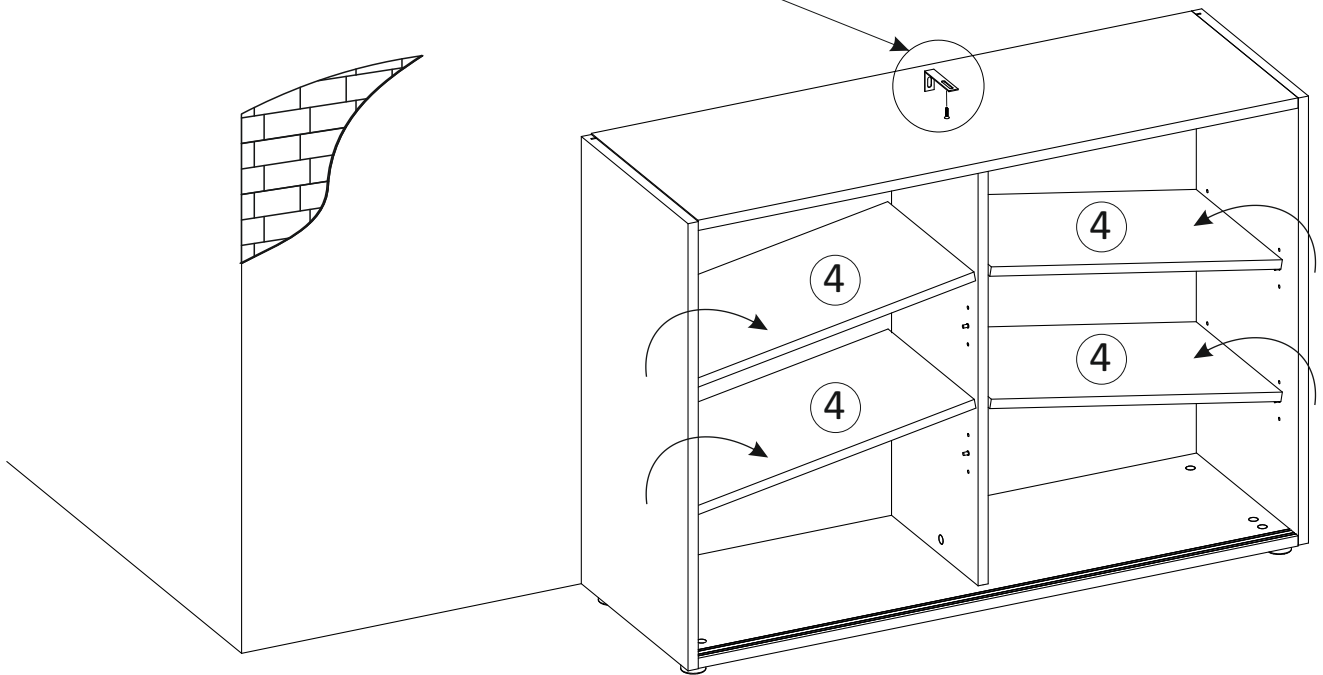
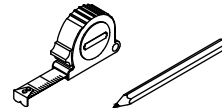
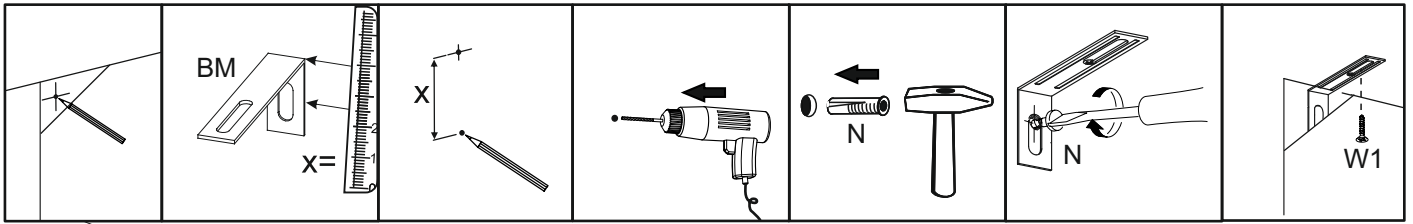
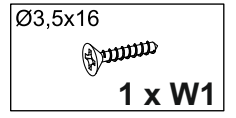
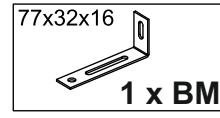
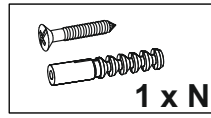

# I

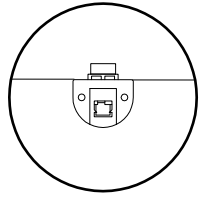
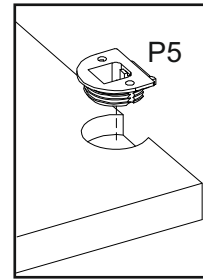
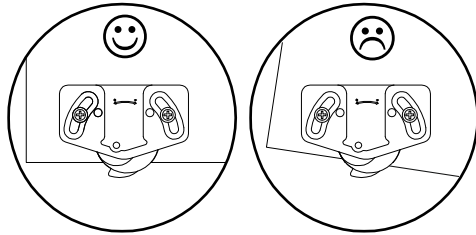
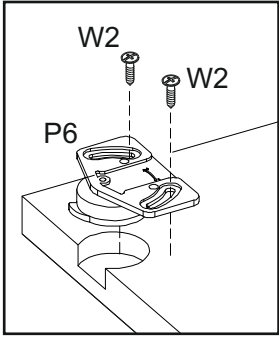
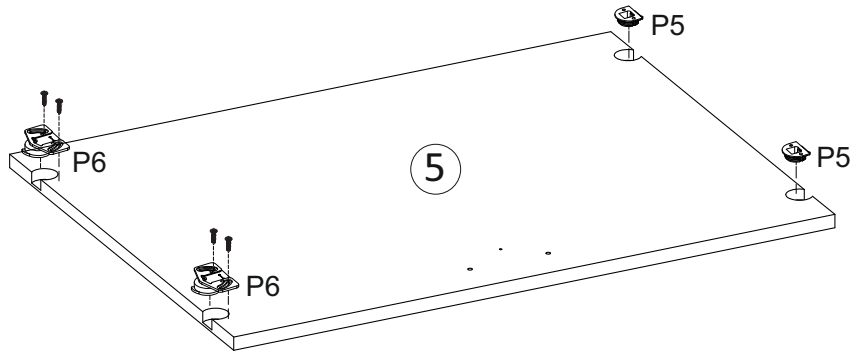
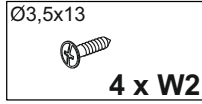
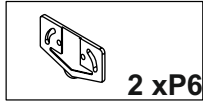
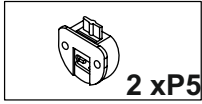

# J

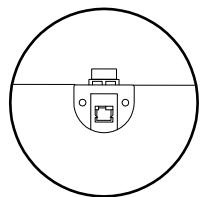
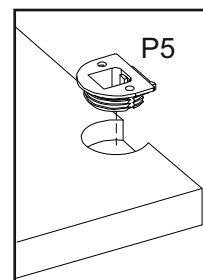
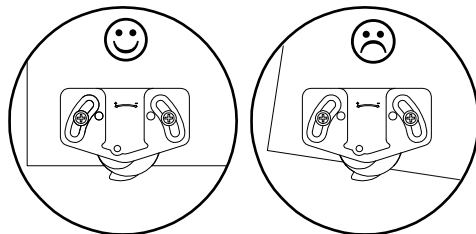
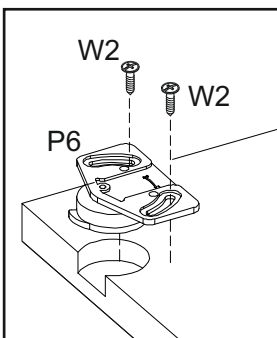
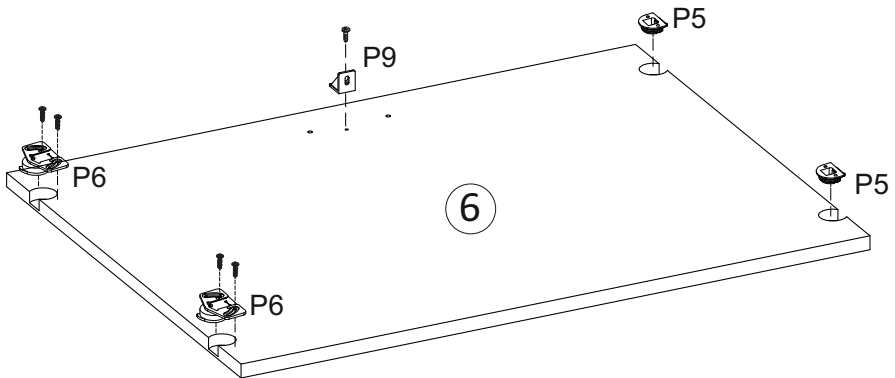
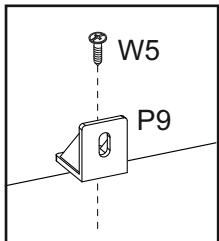
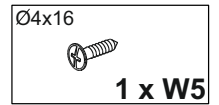
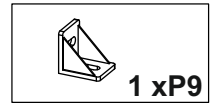
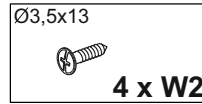
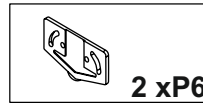
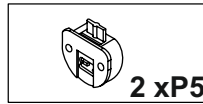

K

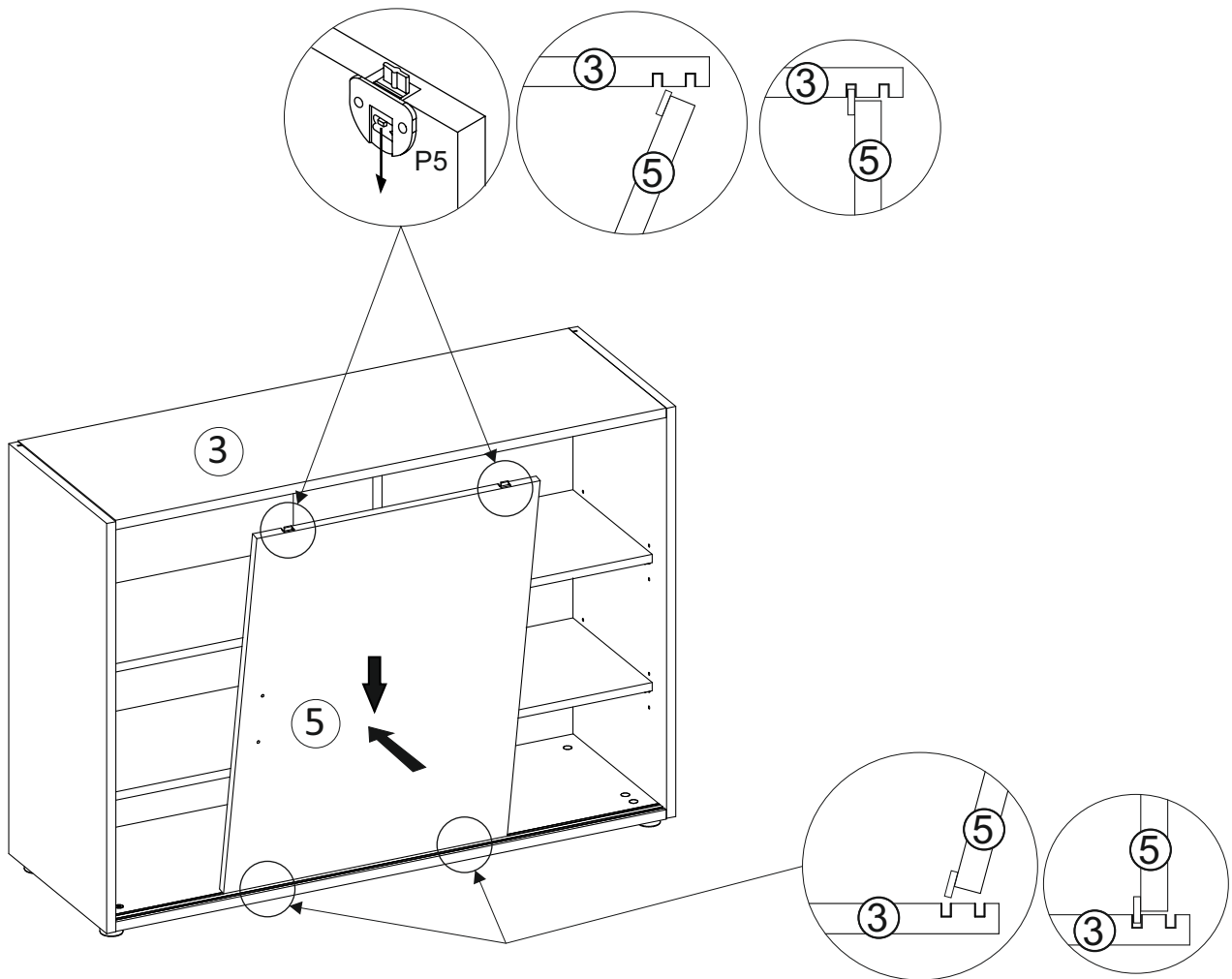

L

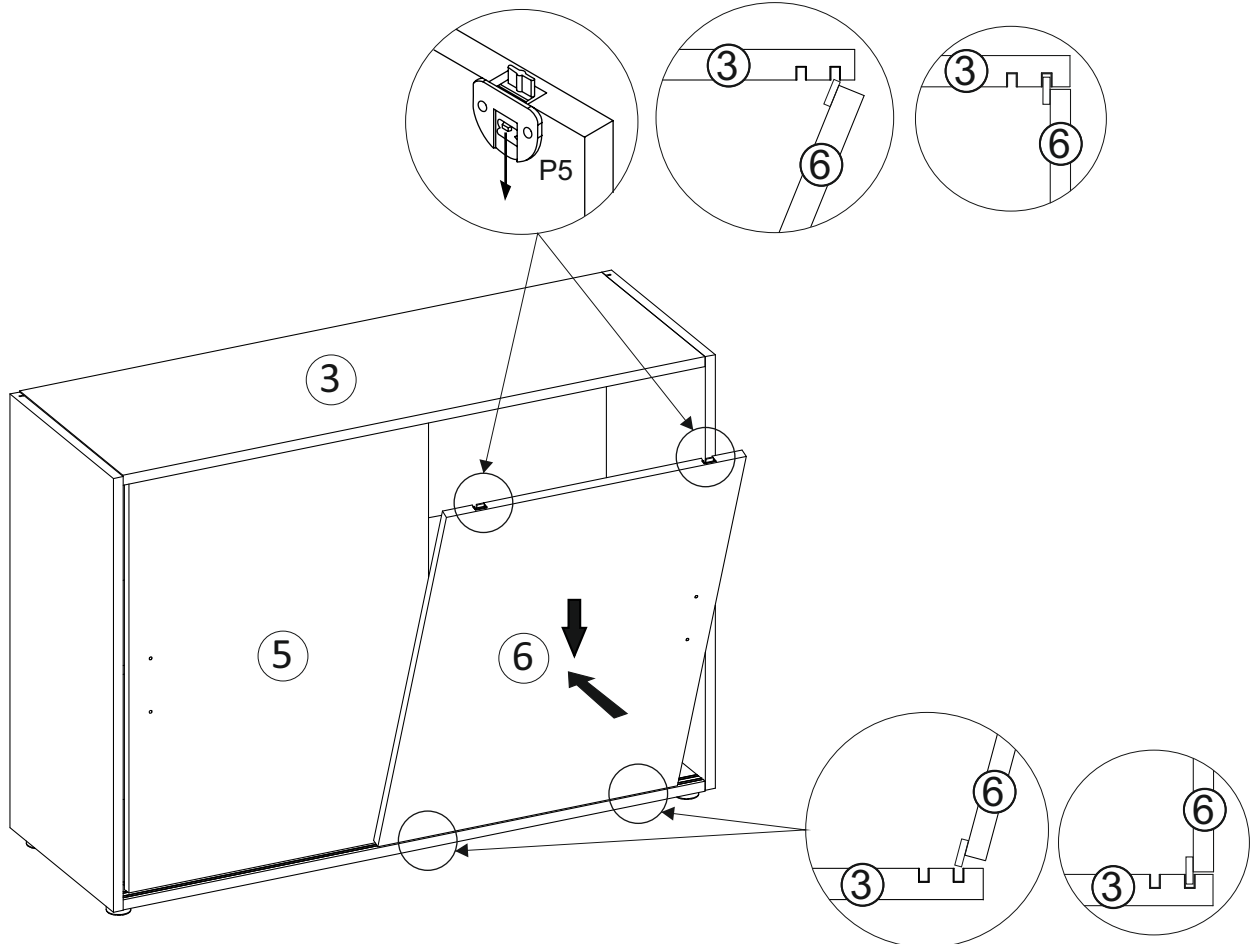

# M

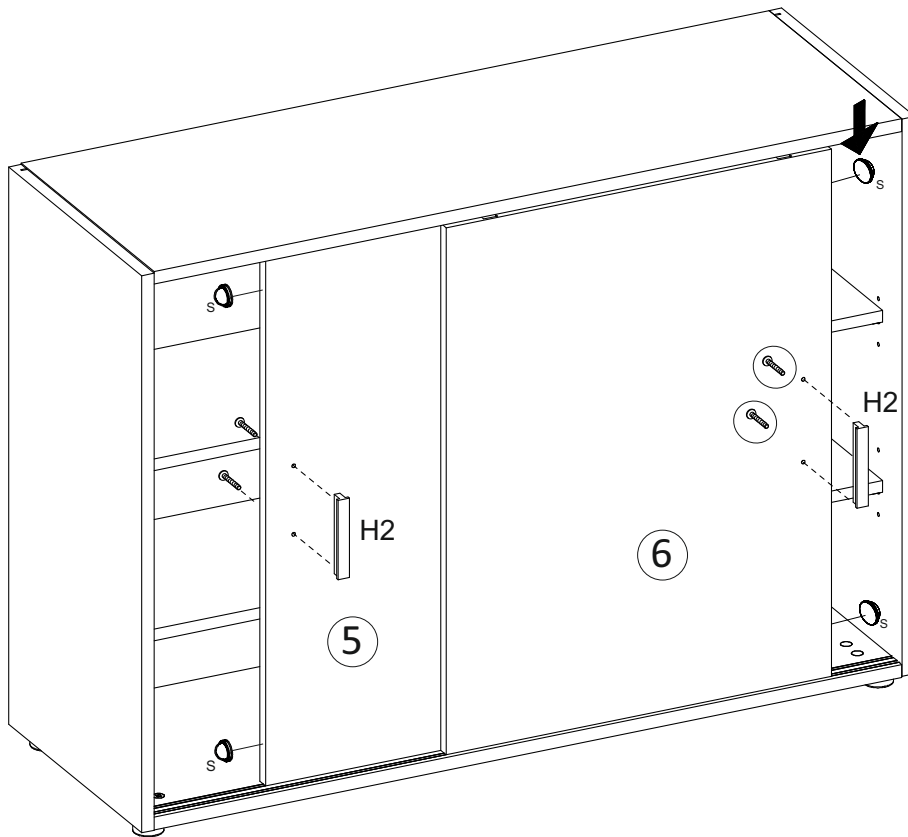
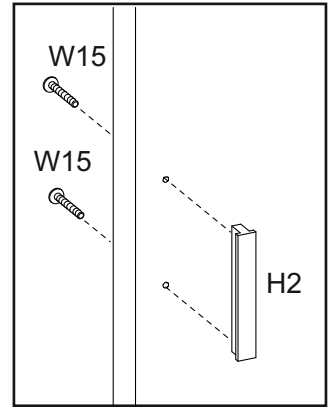
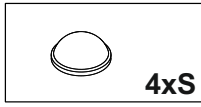
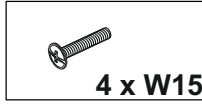
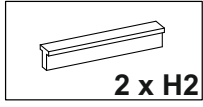

INTERMEBLE Sp. z o.o.  
Sompolinek 18,  
62-610 Sompolno, Poland

@reklamacje@intermeble.com.pl

☎ 0048 63 262 30 33

Nr. Art. 5002970

IAN 437070\_2304

16/16