

## STAPLE GUN SET

GB  IE  NL **STAPLE GUN SET**

Operation and safety notes

DK **HÆFTEPISTOL**

Brugs- og sikkerhedsanvisninger

FR  BE **AGRAFEUSE MANUELLE**

Instructions d'utilisation et consignes de sécurité

NL  BE **NIETPISTOOLSET**

Bedienings- en veiligheidsinstructies

DE  AT  CH **HANDTACKER-SET**

Bedienungs- und Sicherheits Hinweise

GB  IE  NL  DK  NL **IAN 322487\_1901**

OS  BE  OS  NL

**Note:** You can use three different types of staples/ nails in the stapler gun; flat crown staples, round crown staples and T-nails.

- Follow these steps:**
- Press in the staple pusher **3** slightly and then pull it downwards. Then pull the staple pusher **3** completely out of the magazine **5** (see Fig. A).
  - Push the staples or the T-nails into the magazine **5**.
  - CAUTION!** Ensure that the staples or T-nails are correctly inserted (see Figs. B, C, D).
  - Push the staple pusher **3** back into the magazine **5**. Press in the staple pusher **3** slightly and then pull it slightly upwards to fix it in place.

**Examples of use:**

- Attaching coverings to the seating surface of chairs.
- Attaching a skirting at the joint between wall and floor coverings.
- Stretching and stapling canvasses to frames.
- Attaching protective films to insulation materials when installing thermal insulation.
- Attaching decorative materials.

**Removing staples**

- Ensure that the operating handle **2** will not be pressed.
- Push the hook **4** under the staple or nail head (see Fig. F).
- Pull the rear part of the stapler gun upwards to draw out the staple or nail from the workpiece.

**Setting the impact force**





- Never screw the adjusting screw **1** completely out of the stapler gun. This could result in damage to the device.
- Screw out the adjusting screw **1** to reduce the impact force.
- Screw in the adjusting screw **1** to increase the impact force.

- Stapling**
- CAUTION!** Never support yourself by placing your hands near or in front of the stapler gun or the workpiece surface. A slip can result in injury.

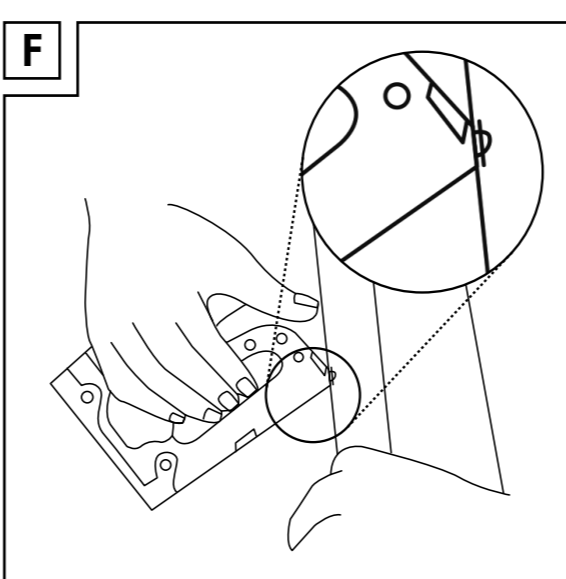
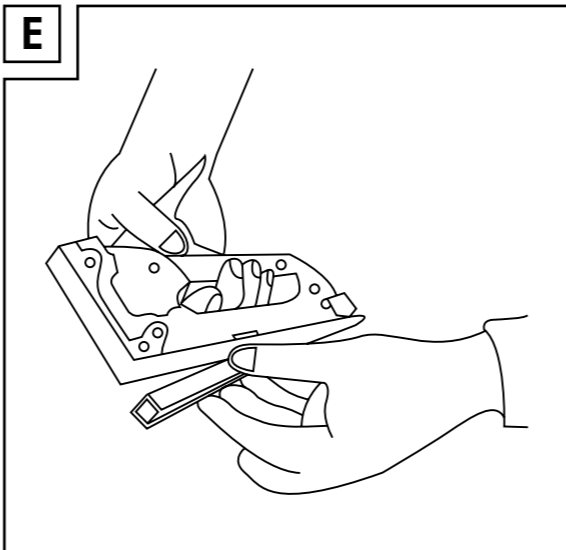
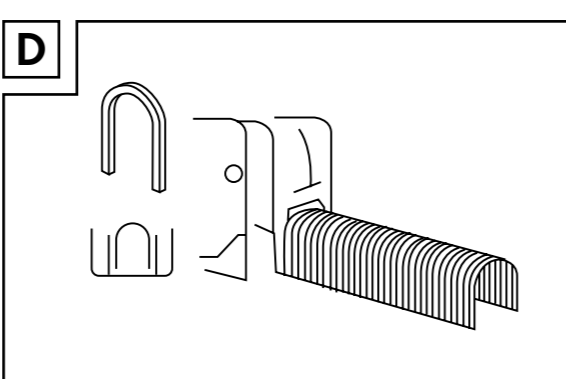
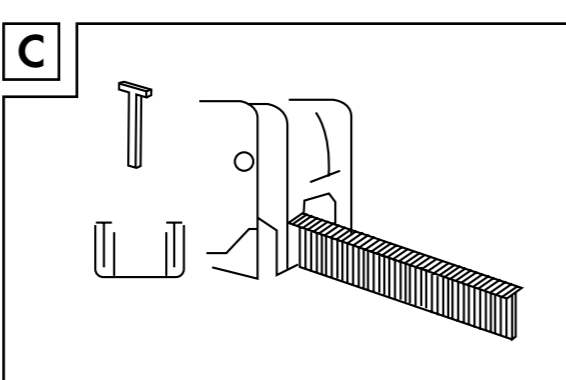
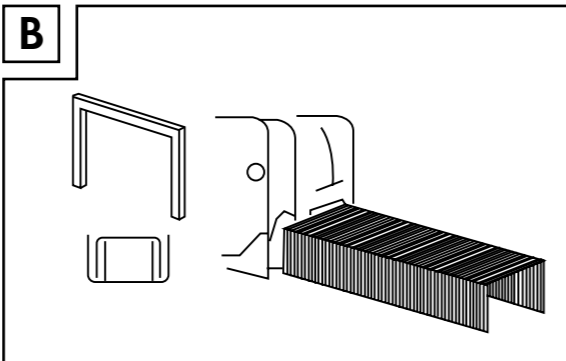
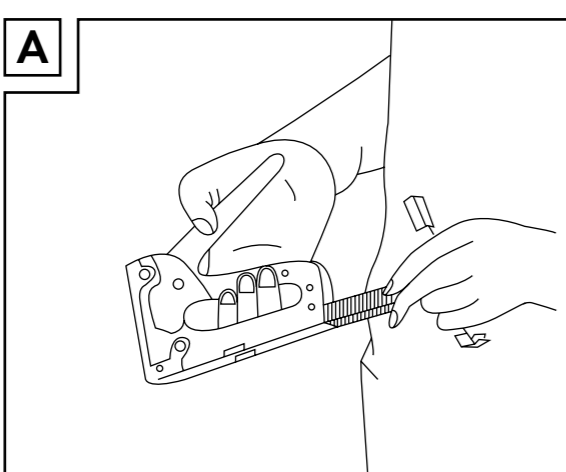
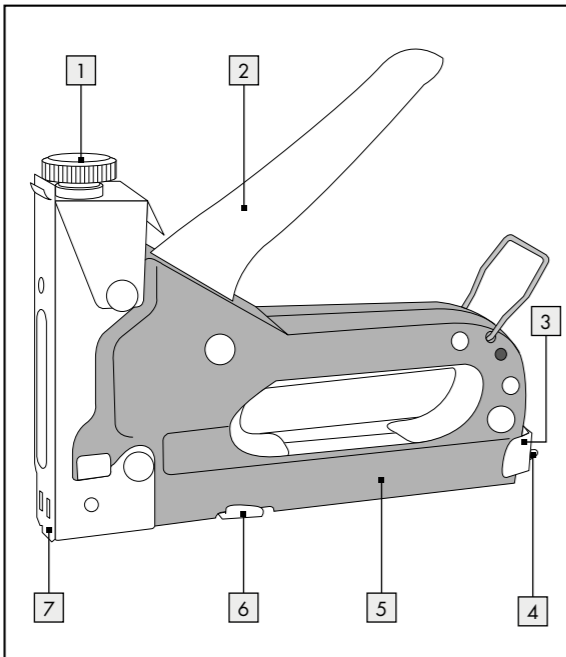
**CAUTION!** Never support yourself by placing your hands near or in front of the stapler gun or the workpiece surface. A slip can result in injury.

- Follow these steps:**
- Press the staple eject opening **7** on the spot where you wish to staple.
  - Adjust the impact force to suit the materials, staples or nails.
  - Press the operating lever **2** down firmly.



<b>List of pictograms used</b>	
	Please read the operating instructions!
	Observe the warnings and safety notices!
	Danger of loss of life and accident to infants and children!
 	Wear personal protective equipment and always wear safety glasses.

- Staple gun set**
- Introduction**
    - We congratulate you on the purchase of your new product. You have chosen a high quality product. Familiarise yourself with the product before using it for the first time. In addition, please carefully refer to the operating instructions and the safety advice below. Only use the product as instructed and only for the indicated field of application. Keep these instructions in a safe place. If you pass the product on to anyone else, please ensure that you also pass on all the documentation with it.

**Proper use**

The stapler gun is intended exclusively for stapling cardboard, leather, cloth (textile or natural fibres) or similar lightweight materials on to hardwood, softwood, chipboard or similar plywood-type materials. Any use other than previously mentioned or any product modification is prohibited and can lead to injuries and/or product damage. The manufacturer is not liable for any

**Proper use**

The stapler gun is intended exclusively for stapling cardboard, leather, cloth (textile or natural fibres) or similar lightweight materials on to hardwood, softwood, chipboard or similar plywood-type materials. Any use other than previously mentioned or any product modification is prohibited and can lead to injuries and/or product damage. The manufacturer is not liable for any

**Proper use**

The stapler gun is intended exclusively for stapling cardboard, leather, cloth (textile or natural fibres) or similar lightweight materials on to hardwood, softwood, chipboard or similar plywood-type materials. Any use other than previously mentioned or any product modification is prohibited and can lead to injuries and/or product damage. The manufacturer is not liable for any

**Proper use**

The stapler gun is intended exclusively for stapling cardboard, leather, cloth (textile or natural fibres) or similar lightweight materials on to hardwood, softwood, chipboard or similar plywood-type materials. Any use other than previously mentioned or any product modification is prohibited and can lead to injuries and/or product damage. The manufacturer is not liable for any

**Proper use**

The stapler gun is intended exclusively for stapling cardboard, leather, cloth (textile or natural fibres) or similar lightweight materials on to hardwood, softwood, chipboard or similar plywood-type materials. Any use other than previously mentioned or any product modification is prohibited and can lead to injuries and/or product damage. The manufacturer is not liable for any

**Proper use**

The stapler gun is intended exclusively for stapling cardboard, leather, cloth (textile or natural fibres) or similar lightweight materials on to hardwood, softwood, chipboard or similar plywood-type materials. Any use other than previously mentioned or any product modification is prohibited and can lead to injuries and/or product damage. The manufacturer is not liable for any

**Proper use**

The stapler gun is intended exclusively for stapling cardboard, leather, cloth (textile or natural fibres) or similar lightweight materials on to hardwood, softwood, chipboard or similar plywood-type materials. Any use other than previously mentioned or any product modification is prohibited and can lead to injuries and/or product damage. The manufacturer is not liable for any

**Proper use**

The stapler gun is intended exclusively for stapling cardboard, leather, cloth (textile or natural fibres) or similar lightweight materials on to hardwood, softwood, chipboard or similar plywood-type materials. Any use other than previously mentioned or any product modification is prohibited and can lead to injuries and/or product damage. The manufacturer is not liable for any

**Proper use**

The stapler gun is intended exclusively for stapling cardboard, leather, cloth (textile or natural fibres) or similar lightweight materials on to hardwood, softwood, chipboard or similar plywood-type materials. Any use other than previously mentioned or any product modification is prohibited and can lead to injuries and/or product damage. The manufacturer is not liable for any

**Proper use**

The stapler gun is intended exclusively for stapling cardboard, leather, cloth (textile or natural fibres) or similar lightweight materials on to hardwood, softwood, chipboard or similar plywood-type materials. Any use other than previously mentioned or any product modification is prohibited and can lead to injuries and/or product damage. The manufacturer is not liable for any

**Proper use**

The stapler gun is intended exclusively for stapling cardboard, leather, cloth (textile or natural fibres) or similar lightweight materials on to hardwood, softwood, chipboard or similar plywood-type materials. Any use other than previously mentioned or any product modification is prohibited and can lead to injuries and/or product damage. The manufacturer is not liable for any

**Proper use**

The stapler gun is intended exclusively for stapling cardboard, leather, cloth (textile or natural fibres) or similar lightweight materials on to hardwood, softwood, chipboard or similar plywood-type materials. Any use other than previously mentioned or any product modification is prohibited and can lead to injuries and/or product damage. The manufacturer is not liable for any

**Proper use**

The stapler gun is intended exclusively for stapling cardboard, leather, cloth (textile or natural fibres) or similar lightweight materials on to hardwood, softwood, chipboard or similar plywood-type materials. Any use other than previously mentioned or any product modification is prohibited and can lead to injuries and/or product damage. The manufacturer is not liable for any

**Proper use**

The stapler gun is intended exclusively for stapling cardboard, leather, cloth (textile or natural fibres) or similar lightweight materials on to hardwood, softwood, chipboard or similar plywood-type materials. Any use other than previously mentioned or any product modification is prohibited and can lead to injuries and/or product damage. The manufacturer is not liable for any

**Proper use**

The stapler gun is intended exclusively for stapling cardboard, leather, cloth (textile or natural fibres) or similar lightweight materials on to hardwood, softwood, chipboard or similar plywood-type materials. Any use other than previously mentioned or any product modification is prohibited and can lead to injuries and/or product damage. The manufacturer is not liable for any

**Proper use**

The stapler gun is intended exclusively for stapling cardboard, leather, cloth (textile or natural fibres) or similar lightweight materials on to hardwood, softwood, chipboard or similar plywood-type materials. Any use other than previously mentioned or any product modification is prohibited and can lead to injuries and/or product damage. The manufacturer is not liable for any

**Proper use**

The stapler gun is intended exclusively for stapling cardboard, leather, cloth (textile or natural fibres) or similar lightweight materials on to hardwood, softwood, chipboard or similar plywood-type materials. Any use other than previously mentioned or any product modification is prohibited and can lead to injuries and/or product damage. The manufacturer is not liable for any

**Proper use**

The stapler gun is intended exclusively for stapling cardboard, leather, cloth (textile or natural fibres) or similar lightweight materials on to hardwood, softwood, chipboard or similar plywood-type materials. Any use other than previously mentioned or any product modification is prohibited and can lead to injuries and/or product damage. The manufacturer is not liable for any

**Proper use**

The stapler gun is intended exclusively for stapling cardboard, leather, cloth (textile or natural fibres) or similar lightweight materials on to hardwood, softwood, chipboard or similar plywood-type materials. Any use other than previously mentioned or any product modification is prohibited and can lead to injuries and/or product damage. The manufacturer is not liable for any

**Proper use**

The stapler gun is intended exclusively for stapling cardboard, leather, cloth (textile or natural fibres) or similar lightweight materials on to hardwood, softwood, chipboard or similar plywood-type materials. Any use other than previously mentioned or any product modification is prohibited and can lead to injuries and/or product damage. The manufacturer is not liable for any

**Proper use**

The stapler gun is intended exclusively for stapling cardboard, leather, cloth (textile or natural fibres) or similar lightweight materials on to hardwood, softwood, chipboard or similar plywood-type materials. Any use other than previously mentioned or any product modification is prohibited and can lead to injuries and/or product damage. The manufacturer is not liable for any

**Proper use**

The stapler gun is intended exclusively for stapling cardboard, leather, cloth (textile or natural fibres) or similar lightweight materials on to hardwood, softwood, chipboard or similar plywood-type materials. Any use other than previously mentioned or any product modification is prohibited and can lead to injuries and/or product damage. The manufacturer is not liable for any

**Proper use**

The stapler gun is intended exclusively for stapling cardboard, leather, cloth (textile or natural fibres) or similar lightweight materials on to hardwood, softwood, chipboard or similar plywood-type materials. Any use other than previously mentioned or any product modification is prohibited and can lead to injuries and/or product damage. The manufacturer is not liable for any

**Proper use**

The stapler gun is intended exclusively for stapling cardboard, leather, cloth (textile or natural fibres) or similar lightweight materials on to hardwood, softwood, chipboard or similar plywood-type materials. Any use other than previously mentioned or any product modification is prohibited and can lead to injuries and/or product damage. The manufacturer is not liable for any

**Proper use**

The stapler gun is intended exclusively for stapling cardboard, leather, cloth (textile or natural fibres) or similar lightweight materials on to hardwood, softwood, chipboard or similar plywood-type materials. Any use other than previously mentioned or any product modification is prohibited and can lead to injuries and/or product damage. The manufacturer is not liable for any

**Proper use**

The stapler gun is intended exclusively for stapling cardboard, leather, cloth (textile or natural fibres) or similar lightweight materials on to hardwood, softwood, chipboard or similar plywood-type materials. Any use other than previously mentioned or any product modification is prohibited and can lead to injuries and/or product damage. The manufacturer is not liable for any

**Proper use**

The stapler gun is intended exclusively for stapling cardboard, leather, cloth (textile or natural fibres) or similar lightweight materials on to hardwood, softwood, chipboard or similar plywood-type materials. Any use other than previously mentioned or any product modification is prohibited and can lead to injuries and/or product damage. The manufacturer is not liable for any

**Proper use**

The stapler gun is intended exclusively for stapling cardboard, leather, cloth (textile or natural fibres) or similar lightweight materials on to hardwood, softwood, chipboard or similar plywood-type materials. Any use other than previously mentioned or any product modification is prohibited and can lead to injuries and/or product damage. The manufacturer is not liable for any

**Proper use**

The stapler gun is intended exclusively for stapling cardboard, leather, cloth (textile or natural fibres) or similar lightweight materials on to hardwood, softwood, chipboard or similar plywood-type materials. Any use other than previously mentioned or any product modification is prohibited and can lead to injuries and/or product damage. The manufacturer is not liable for any

**Proper use**

The stapler gun is intended exclusively for stapling cardboard, leather, cloth (textile or natural fibres) or similar lightweight materials on to hardwood, softwood, chipboard or similar plywood-type materials. Any use other than previously mentioned or any product modification is prohibited and can lead to injuries and/or product damage. The manufacturer is not liable for any

**Proper use**

The stapler gun is intended exclusively for stapling cardboard, leather, cloth (textile or natural fibres) or similar lightweight materials on to hardwood, softwood, chipboard or similar plywood-type materials. Any use other than previously mentioned or any product modification is prohibited and can lead to injuries and/or product damage. The manufacturer is not liable for any

**Proper use**

The stapler gun is intended exclusively for stapling cardboard, leather, cloth (textile or natural fibres) or similar lightweight materials on to hardwood, softwood, chipboard or similar plywood-type materials. Any use other than previously mentioned or any product modification is prohibited and can lead to injuries and/or product damage. The manufacturer is not liable for any

**Proper use**

The stapler gun is intended exclusively for stapling cardboard, leather, cloth (textile or natural fibres) or similar lightweight materials on to hardwood, softwood, chipboard or similar plywood-type materials. Any use other than previously mentioned or any product modification is prohibited and can lead to injuries and/or product damage. The manufacturer is not liable for any

**Proper use**

The stapler gun is intended exclusively for stapling cardboard, leather, cloth (textile or natural fibres) or similar lightweight materials on to hardwood, softwood, chipboard or similar plywood-type materials. Any use other than previously mentioned or any product modification is prohibited and can lead to injuries and/or product damage. The manufacturer is not liable for any

**Proper use**

The stapler gun is intended exclusively for stapling cardboard, leather, cloth (textile or natural fibres) or similar lightweight materials on to hardwood, softwood, chipboard or similar plywood-type materials. Any use other than previously mentioned or any product modification is prohibited and can lead to injuries and/or product damage. The manufacturer is not liable for any

**Proper use**

The stapler gun is intended exclusively for stapling cardboard, leather, cloth (textile or natural fibres) or similar lightweight materials on to hardwood, softwood, chipboard or similar plywood-type materials. Any use other than previously mentioned or any product modification is prohibited and can lead to injuries and/or product damage. The manufacturer is not liable for any

**Proper use**

The stapler gun is intended exclusively for stapling cardboard, leather, cloth (textile or natural fibres) or similar lightweight materials on to hardwood, softwood, chipboard or similar plywood-type materials. Any use other than previously mentioned or any product modification is prohibited and can lead to injuries and/or product damage. The manufacturer is not liable for any

**Proper use**

The stapler gun is intended exclusively for stapling cardboard, leather, cloth (textile or natural fibres) or similar lightweight materials on to hardwood, softwood, chipboard or similar plywood-type materials. Any use other than previously mentioned or any product modification is prohibited and can lead to injuries and/or product damage. The manufacturer is not liable for any

**Proper use**

The stapler gun is intended exclusively for stapling cardboard, leather, cloth (textile or natural fibres) or similar lightweight materials on to hardwood, softwood, chipboard or similar plywood-type materials. Any use other than previously mentioned or any product modification is prohibited and can lead to injuries and/or product damage. The manufacturer is not liable for any

**Proper use**

The stapler gun is intended exclusively for stapling cardboard, leather, cloth (textile or natural fibres) or similar lightweight materials on to hardwood, softwood, chipboard or similar plywood-type materials. Any use other than previously mentioned or any product modification is prohibited and can lead to injuries and/or product damage. The manufacturer is not liable for any

**Proper use**

The stapler gun is intended exclusively for stapling cardboard, leather, cloth (textile or natural fibres) or similar lightweight materials on to hardwood, softwood, chipboard or similar plywood-type materials. Any use other than previously mentioned or any product modification is prohibited and can lead to injuries and/or product damage. The manufacturer is not liable for any

damages caused by any use other than for the intended purpose. The product is not intended for commercial use.

**Description of parts**

- Description of parts**
- |                         |                         |
|-------------------------|-------------------------|
| <b>1</b> Adjusting knob | <b>5</b> Staple channel |
| <b>2</b> Trigger        | <b>6</b> Side wings     |
| <b>3</b> Carriage       | <b>7</b> Driver         |
| <b>4</b> Hook           |                         |

**Supply scope**

Immediately after unpacking, check that the delivery is complete and that the product and all its parts are in perfect condition. Do not under any circumstances assemble the product if the delivery is incomplete.

- Hand-held stapler set
- 500 Staples (8 mm)
- 500 U-staples (12 mm)
- 500 T-nails (10 mm)
  - Instructions for use

**Staples/ nails**

**Note:** The precision components of the device are designed to use the following standard, widely available staples and nails:

**Staples/ nails**

**Staples/ nails**

**Staples/ nails**

**Staples/ nails**

**Staples/ nails**

**Staples/ nails**

**Staples/ nails**

**Staples/ nails**

**Staples/ nails**

**Staples/ nails**

**Staples/ nails**

**Staples/ nails**

**Staples/ nails**

**Staples/ nails**

**Staples/ nails**

**Staples/ nails**

**Staples/ nails**

**Staples/ nails**

**Staples/ nails**

**Staples/ nails**

**Staples/ nails**

**Staples/ nails**

**Staples/ nails**

**Staples/ nails**

**Staples/ nails**

**Staples/ nails**

**Staples/ nails**

**Staples/ nails**

**Staples/ nails**

**Staples/ nails**

**Staples/ nails**

**Staples/ nails**

**Staples/ nails**

**Staples/ nails**

**Staples/ nails**

**Staples/ nails**

**Staples/ nails**

**Staples/ nails**

**Staples/ nails**

**Staples/ nails**

Type	A (mm)	B (mm)	C (mm)
Flat crown staples	4 to max. 14	11,3	1,2 to max. 1,3
Round crown staples	10 to max. 12	6,3	1,2 to max. 1,3
T-nails	10 to max. 14	1,8 to 2,0	1,2 to max. 1,3

**Safety advice**

**KEEP ALL THE SAFETY ADVICE AND INSTRUCTIONS IN A SAFE PLACE FOR FUTURE REFERENCE!**

- WARNING! DANGER OF LOSS OF LIFE AND ACCIDENT TO INFANTS AND CHILDREN!** Never leave children unsupervised with the packaging materials. Danger of suffocation. Keep out of the reach of children. It is not a toy.

- This appliance can be used by children aged from 8 years and above and persons with reduced physical, sensory or mental capabilities or lack of experience and knowledge

**Safety advice**

**Safety advice**

**Safety advice**

**Safety advice**

**Safety advice**

**Safety advice**

**Safety advice**

**Safety advice**

**Safety advice**

**Safety advice**

**Safety advice**

**Safety advice**

**Safety advice**

**Safety advice**

**Safety advice**

**Safety advice**

**Safety advice**

**Safety advice**

**Safety advice**

**Safety advice**

**Safety advice**

**Safety advice**

**Safety advice**

**Safety advice**

**Safety advice**

**Safety advice**

**Safety advice**

**Safety advice**

**Safety advice**

**Safety advice**

**Safety advice**

**Safety advice**

**Safety advice**

**Safety advice**



**Safety advice**

**Safety advice**

**Safety advice**

**Safety advice**

if they have been given supervision or instruction concerning use of the appliance in a safe way and understand the hazards involved. Children shall not play with the appliance. Cleaning and user maintenance shall not be made by children without supervision.

- Always keep the product out of reach of children. Children often underestimate danger. Store the device indoors in an enclosed, dry place where it cannot be reached by children.
- Ensure that staples and nails cannot under any circumstances strike people or animals. Failure to observe this advice may lead to injury.
-    Wear personal protective equipment and always wear safety glasses. This also applies to people who may be helping with the work by supporting or holding the workpiece.
- CAUTION!** Do not support yourself with your hands under any circumstances near or in front of the stapler gun or on the surface being tacked. One slip may result in injury.
- Every time before you use the device, check that it is in perfect condition. Damage to any of its components may lead to injury.
- Check that all parts have been assembled and fitted properly. Incorrect assembly or fitting may lead to injury.
- Remain alert at all times and always watch what

