



**BLUETOOTH®-KAPSELGEHÖRSCHUTZ/ BLUETOOTH®  
EAR DEFENDERS/ CASQUE ANTIBRUIT BLUETOOTH®  
PKB 5 A1**

(DE) (AT) (CH)

**BLUETOOTH®-KAPSELGEHÖRSCHUTZ**

Kurzanleitung

(GB) (IE)

**BLUETOOTH® EAR DEFENDERS**

Quick Start Guide

(FR) (BE)

**CASQUE ANTIBRUIT BLUETOOTH®**

Mode d'emploi rapide

(NL) (BE)

**BLUETOOTH®-OORKAPPEN**

Korte handleiding

(PL)

**NAUSZNIKI BLUETOOTH®**

Krótki instrukcja

(CZ)

**CHRÁNIČE SLUCHU S BLUETOOTH®**

Krátký návod

(SK)

**CHRÁNIČE SLUCHU S BLUETOOTH®**

Krátky návod

DE/AT/CH	Kurzanleitung	Seite	3
GB/IE	Quick start guide	Page	5
FR/BE	Guide de démarrage rapide	Page	7
NL/BE	Snelstartgids	Pagina	9
PL	Skrócona instrukcja obsługi	Strona	11
CZ	Stručná příručka	Strana	13
SK	Návod na rýchle spustenie	Strana	15

Diese Kurzanleitung ist fester Bestandteil der Bedienungsanleitung. Bewahren Sie diese zusammen mit der Bedienungsanleitung gut auf. Händigen Sie alle Unterlagen bei Weitergabe des Produkts an Dritte mit aus. Lesen Sie vor der Verwendung die Bedienungsanleitung und beachten Sie insbesondere die darin enthaltenen Sicherheitshinweise..

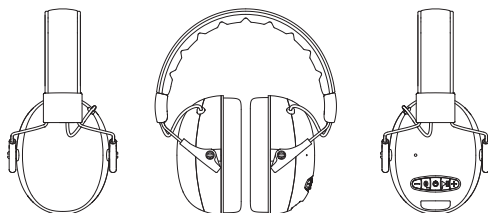

1

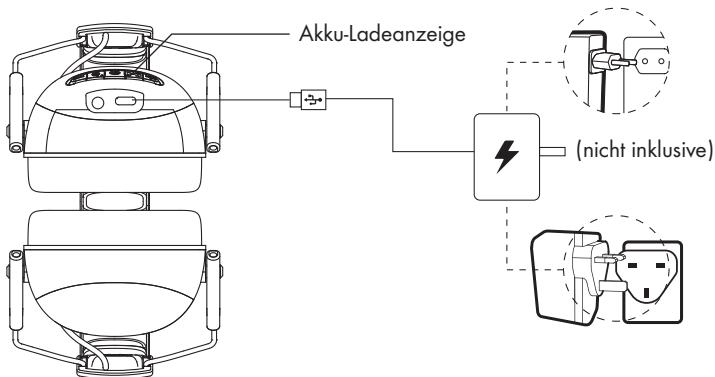

2

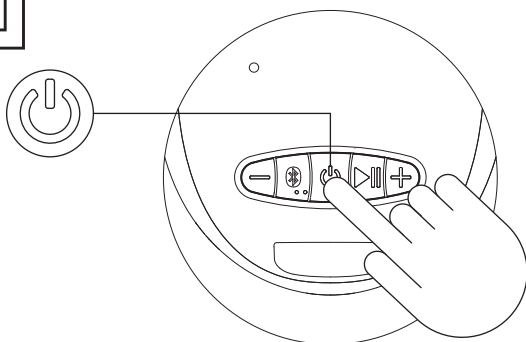

Drücken und halten Sie für ca. 3 Sekunden bis ein Signalton erklingt. Der Kopfhörer befindet sich nun im Pairing-Modus und die blaue / weiße LED blinkt.

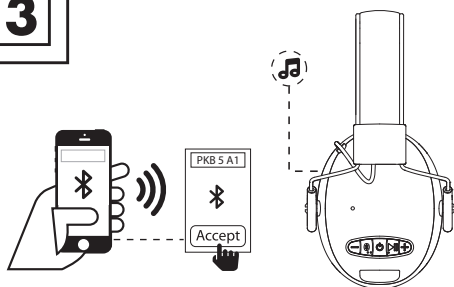
**3**

Wählen Sie „PKB 5 A1“ aus der Liste der Kommunikationsgeräte und bestätigen Sie die Verbindung.

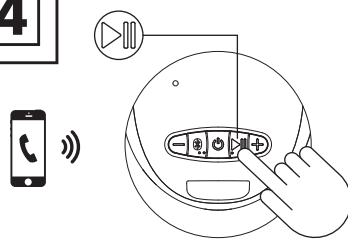
**4**

Drücken Sie die ►►-Taste, wenn Sie einen Anruf annehmen / beenden möchten.

### Kopfhörer-Status



Pairing Modus



Verbundener Modus



niedriger Batteriestand

### LED-Anzeige



Weiß



Blau

Die LED blinkt einmal pro Sekunde weiß und blau.



Blau

Blinkt zweimal alle 5 Sekunden



Weiß

Blinkt einmal alle 3 Sekunden

This quick reference guide is a fixed part of the operating instructions. Keep both this and the operating instructions in a safe place. When passing this product on to third parties, please be sure to include all documentation. Read the operating instructions before use, and pay particular attention to the safety instructions included in the operating instructions.

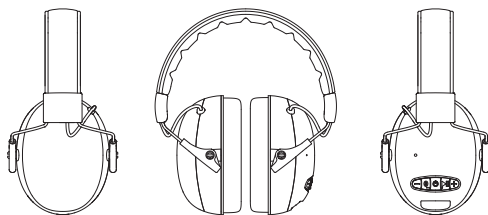

1

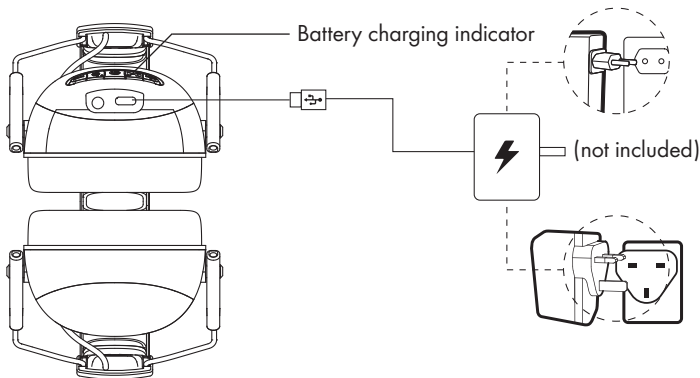

2

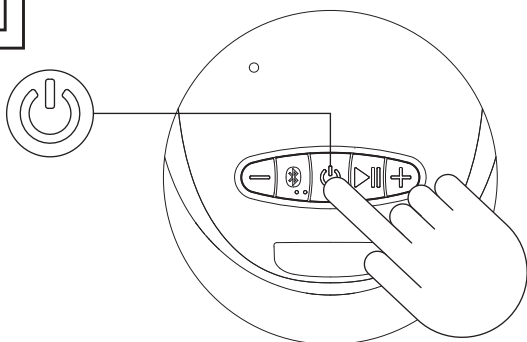

Press and hold for approx. 3 seconds until you hear an acoustic sound. It means the headphones are in pairing mode and the blue / white LED will flash.

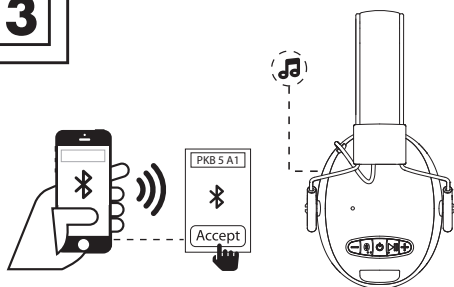
**3**

Select "PKB 5 A1" from the list of communication devices and confirm the connection.

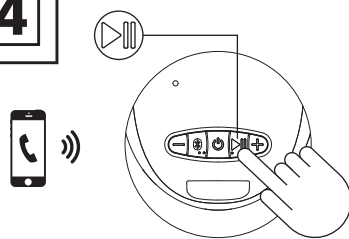
**4**

To answer/end incoming call, press the ►|| button.

### Headphone Status



Pairing mode



Paired mode



Low battery

### LED Display



White



Blue

The LED flashes once per second in white and blue.



Blue

Flashes twice every 5 seconds.



White

Flashes once every 3 seconds.

Ce guide rapide fait partie intégrante du mode d'emploi. Conservez-le soigneusement avec le mode d'emploi. Lorsque vous remettez le produit à d'autres utilisateurs, veuillez également leur transmettre tous les documents liés à celui-ci. Lisez avant l'utilisation le mode d'emploi et respectez tout particulièrement les consignes de sécurité qui y figurent.

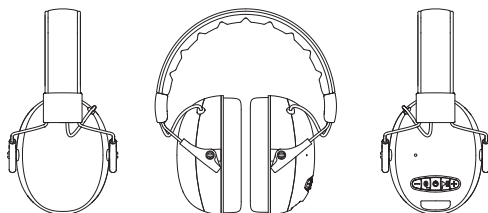
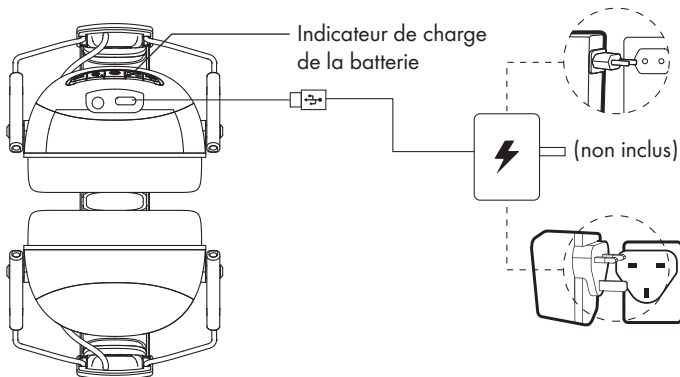
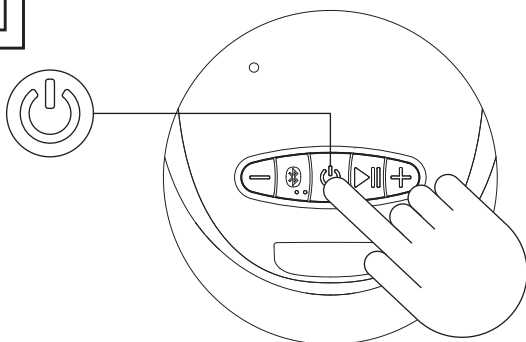
**1****2**

Appuyez et maintenez pendant environ 3 secondes jusqu'à ce que vous entendiez un son. Cela indique que les écouteurs sont en mode d'appairage ; le voyant LED bleu/blanc clignotera.

3

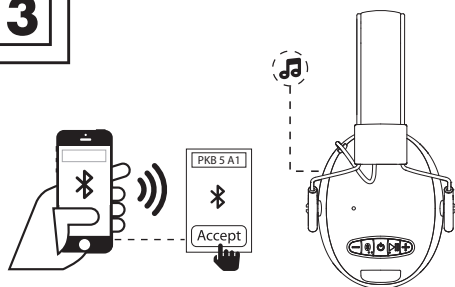

Sélectionnez « PKB 5 A1 » dans la liste des appareils de communication et confirmez la connexion.

4

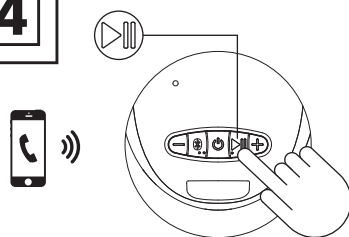

Pour répondre/terminer l'appel entrant, appuyez sur le bouton ►||

### État du casque



Mode d'appairage



Mode appairé



Batterie faible

### Affichage LED



Blanc



Bleu

Le voyant LED clignote une fois par seconde en blanc et bleu.



Bleu

Clignote deux fois toutes les 5 secondes.



Blanc

Clignote une fois toutes les 3 secondes.



Deze beknopte handleiding is vast bestanddeel van de gebruiksaanwijzing. Bewaar hem samen met de gebruiksaanwijzing goed. Overhandig alle documenten bij doorgifte van het product aan derden. Lees voor het gebruik de gebruiksaanwijzing en neem in het bijzonder de hierin vermelde veiligheidsvoorschriften in acht.

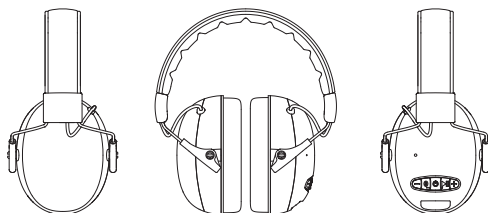

1

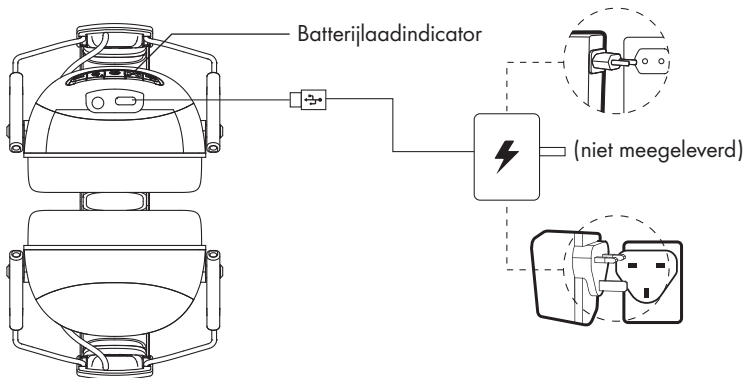

2

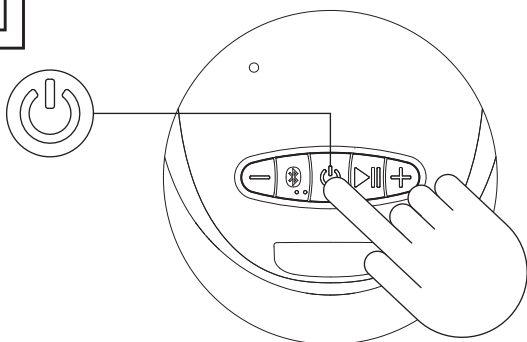

Houd ongeveer 3 seconden ingedrukt totdat u een akoestisch geluid hoort. Dit betekent dat de koptelefoons in de koppelmodus staan en het blauwe / witte LED-lampje zal knipperen.

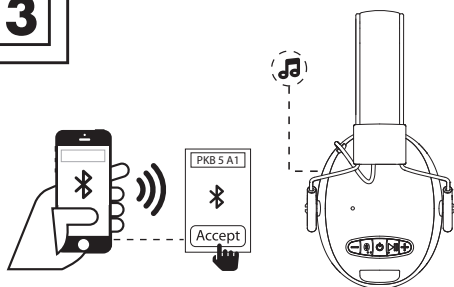
**3**

Selecteer "PKB 5 A1" in de lijst met communicatie-apparaten en bevestig de verbinding.

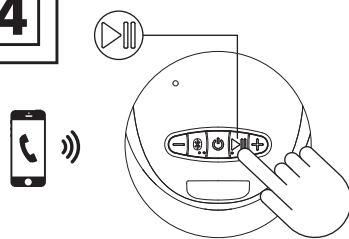
**4**

Voor het beantwoorden/beeindigen van een binnenkomende oproep, drukt u op de knop .

### Status koptelefoon



Koppelmodus



Gekoppelde modus



Batterij bijna leeg

### LED-display



Wit



Blauw

Het LED-lampje knippert eenmaal per seconde wit en blauw.



Blauw

Knippert tweemaal om de 5 seconden.



Wit

Knippert eenmaal om de 3 seconden.

## PL Krótka instrukcja

Ta krótka instrukcja obsługi jest stałą częścią składową instrukcji obsługi. Należy ją zachować wraz z instrukcją obsługi. W przypadku przekazania produktu innej osobie należy dołączyć do niego całą jego dokumentację. Przed użyciem należy przeczytać instrukcję obsługi i szczególnie przestrzegać zawartych w niej wskazówek dotyczących bezpieczeństwa.

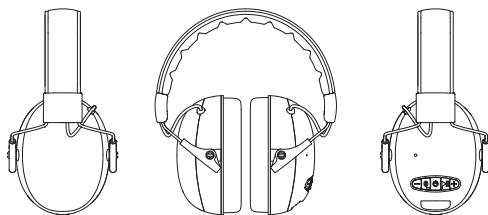

1

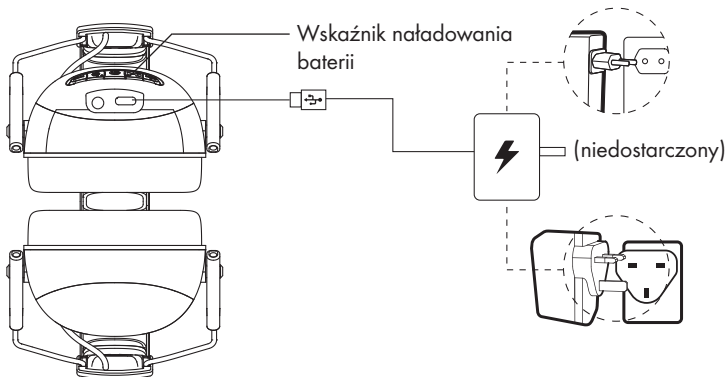

2

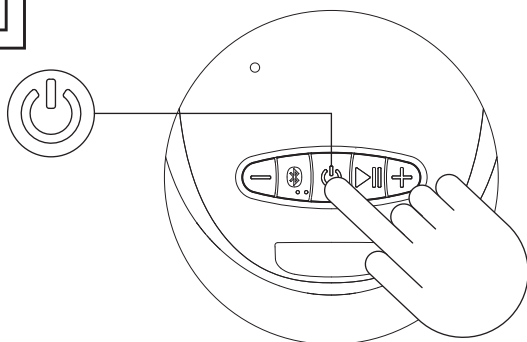

Naciśnij i przytrzymaj na około 3 sekundy, aż do usłyszenia dźwięku sygnału akustycznego. Oznacza to, że słuchawki znajdują się w trybie parowania i zacznie migać niebieskie / białe światło LED.

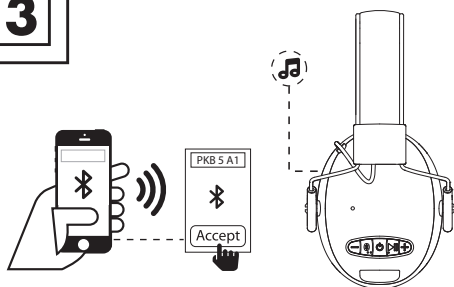
**3**

Wybierz "PKB 5 A1" z listy urządzeń komunikacyjnych i potwierdź połączenie.

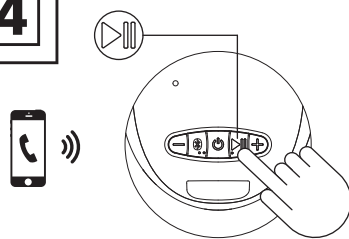
**4**

W celu odpowiedzi/zakończenia przychodzącego połączenia, naciśnij przycisk .

### Stan słuchawek



Tryb parowania



Tryb wykonania parowania



Słabe naładowania baterii

### Wyświetlacz LED



Biały



Niebieski

Pojedyncze mignięcie białym i niebieskim światłem LED, co sekundę.



Niebieski

Dwukrotne mignięcie, co 5 sekund.



Biały

Dwukrotne mignięcie, co 3 sekundy.

## CZ Krátký návod

Tento stručný návod je nedílnou součástí návodu k obsluze. Uložte jej společně s návodem k obsluze. Při předávání výrobku třetí osobě současně předávejte i všechny související podklady. Před použitím si přečtěte návod k obsluze a dodržujte především bezpečnostní předpisy, které jsou v něm obsaženy.

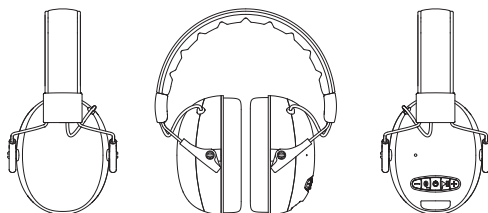

1

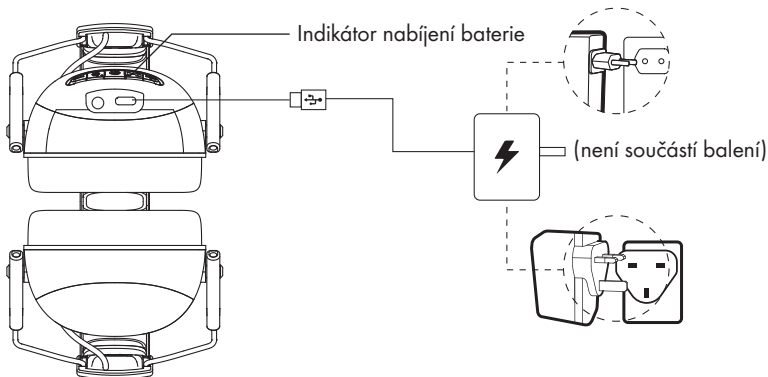

2

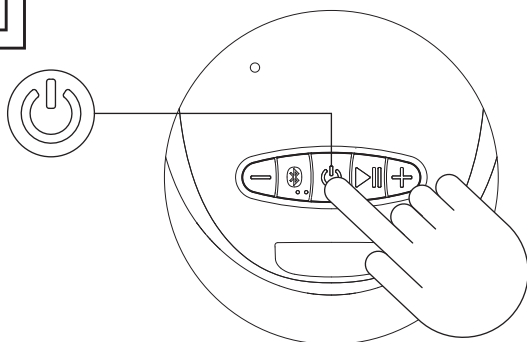

Stiskněte a přibližně 3 sekundy podržte, dokud neuslyšíte zvuk. Znamená to, že sluchátka jsou v režimu párování, a bude blikat modrý/bílý indikátor.

3

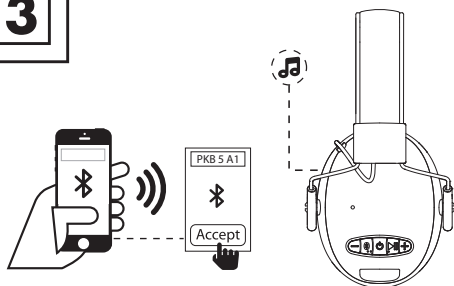

V seznamu komunikačních zařízení vyberte položku „PKB 5 A1“ a potvrďte připojení.

4

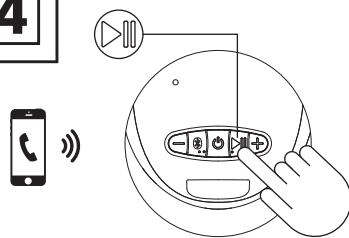

Pokud chcete přijmout nebo ukončit příchozí hovor, stiskněte tlačítko ►||

### Stav sluchátek



Režim párování



Spárovaný režim



Nízké napětí baterie

### Stav indikátoru



Bílá



Modrá

Indikátor bliká jednou za sekundu bílou a modrou barvou.



Modrá

Bliká dvakrát každých 5 sekund.



Bílá

Bliká jednou každé 3 sekundy.

Tento krátky návod je pevnou súčasťou návodu na obsluhu. Dobro ho uschovajte spolu s návodom na obsluhu. Ak odovzdávate výrobok ďalšej osobe, priložte k nemu aj všetky podklady. Pred používaním si pozorne prečítajte návod na obsluhu a dodržiavajte najmä v ňom uvedené bezpečnostné pokyny.

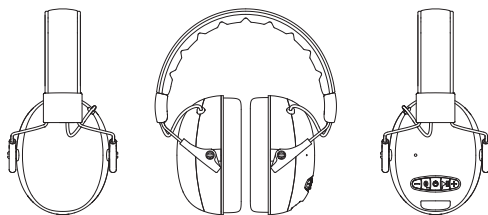
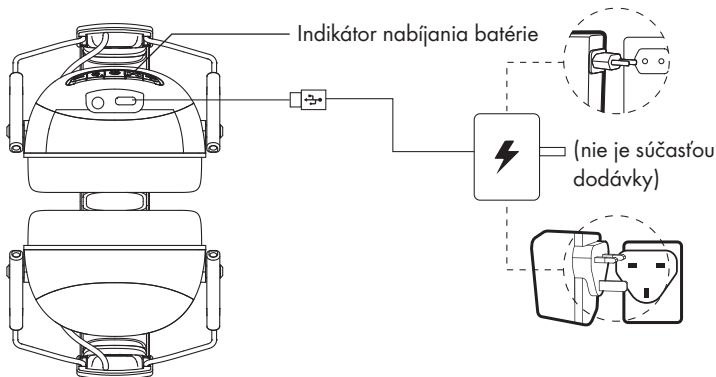
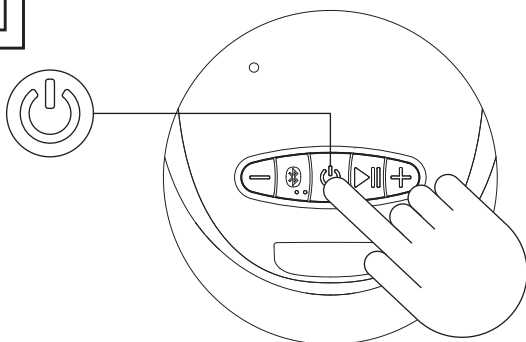
**1****2**

Podržte stlačené tlačidlo približne na 3 sekundy dovedy, kým sa nezvoze akustický signál. To znamená, že sa slúchadlá nachádzajú v režime párovania a bude blikaf modrý/biely LED indikátor.

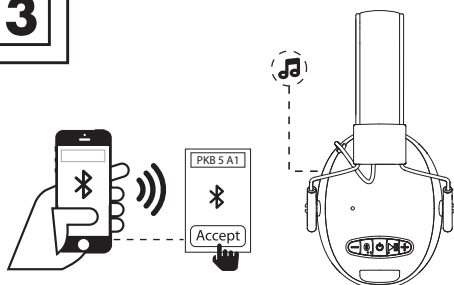
**3**

Zvoľte „PKB 5 A1“ zo zoznamu komunikačných zariadení a potvrdte pripojenie.

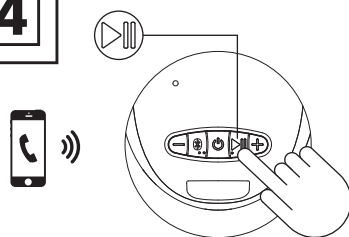
**4**

Ak chcete prijať/ukončiť prichádzajúcu hovor, stlačte tlačidlo ►||

### Stav slúchadiel



Režim párovania



Režim spárovania



Takmer vybitá batéria

### LED displej



Biela



Modrá

LED indikátor bliká raz za sekundu bielou a modrou farbou.



Modrá

Bliká dvakrát každých 5 sekúnd.



Biela

Bliká raz každé 3 sekundy.





**OWIM GmbH & Co. KG**

Stiftsbergstraße 1  
74167 Neckarsulm  
GERMANY

Model No.: HG06608A/ HG06608B

Version: 07/2020

IAN 346570\_2001