

# crelândo®

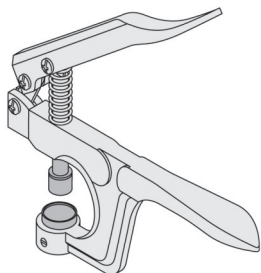

Style No.: 1142



## DRUCKKNOPF-SET MIT ZANGE

(DE) (AT) (CH)

### DRUCKKNOPF-SET MIT ZANGE

Gebrauchsanleitung

(FR) (CH)

### SET DE BOUTONS- PRESSION AVEC PINCE

Instructions d'installation

(IT) (CH)

### SET BOTTONI A PRESSIONE CON PINZA

Istruzioni per l'installazione

















































































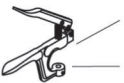



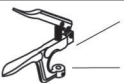









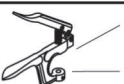

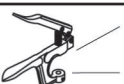

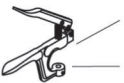



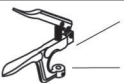









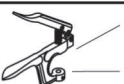

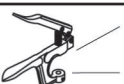

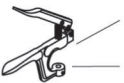



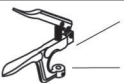



(GB)

### PRESS STUD SET WITH PLIERS

Assembly instructions

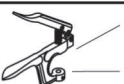
IAN 354162\_2010

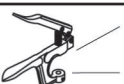
(DE) (AT) (CH)  
(FR) (IT) (GB)

<p>Sie benötigen:          Auxiliaires nécessaires:          Occorrente:          You will need:</p> 	<p>Werkzeug:          Outil:          Strumento:          Tool:</p> 																
<p>Druckknöpfe:          Boutons:          Pulsanti:          Buttons:</p>	<table border="1"> <tr> <td data-bbox="498 262 681 326"> <b>A</b>   </td> <td data-bbox="684 262 864 326"> <b>a</b>   </td> </tr> <tr> <td data-bbox="498 330 681 395"> <b>M</b>   </td> <td data-bbox="684 330 864 395"> <b>P3</b>   </td> </tr> <tr> <td data-bbox="498 399 681 463"> <b>5</b>   </td> <td data-bbox="684 399 864 463"> <b>P5</b>   </td> </tr> <tr> <td data-bbox="498 467 681 532"> <b>8</b>   </td> <td data-bbox="684 467 864 532"> <b>P8</b>   </td> </tr> </table> <table border="1"> <tr> <td data-bbox="498 522 681 587"> <b>1</b>  20x         </td> <td data-bbox="684 522 864 587"> <b>2</b>  20x         </td> </tr> <tr> <td data-bbox="498 591 681 655"> <b>3</b>  20x         </td> <td data-bbox="684 591 864 655"> <b>4</b>  20x         </td> </tr> <tr> <td data-bbox="498 659 681 714"> <b>5</b>  160x         </td> <td data-bbox="684 659 864 714"> <b>6</b>  80x         </td> </tr> <tr> <td data-bbox="684 659 864 714"> <b>7</b>  80x         </td> <td></td> </tr> </table>	<b>A</b>  	<b>a</b>  	<b>M</b>  	<b>P3</b>  	<b>5</b>  	<b>P5</b>  	<b>8</b>  	<b>P8</b>  	<b>1</b>  20x	<b>2</b>  20x	<b>3</b>  20x	<b>4</b>  20x	<b>5</b>  160x	<b>6</b>  80x	<b>7</b>  80x	
<b>A</b>  	<b>a</b>  																
<b>M</b>  	<b>P3</b>  																
<b>5</b>  	<b>P5</b>  																
<b>8</b>  	<b>P8</b>  																
<b>1</b>  20x	<b>2</b>  20x																
<b>3</b>  20x	<b>4</b>  20x																
<b>5</b>  160x	<b>6</b>  80x																
<b>7</b>  80x																	
<p>Kombinationen:          Combinaisons:          Combinazioni:          Combinations:</p>	<table border="1"> <tr> <td data-bbox="498 718 681 810">  </td> <td data-bbox="684 718 864 810"> <b>A</b>  = <b>3</b>   <b>a</b>  = <b>4</b>  </td> </tr> <tr> <td data-bbox="498 814 681 906">  </td> <td data-bbox="684 814 864 906"> <b>M</b>  = <b>2</b>   <b>P5</b>  = <b>1</b>  </td> </tr> <tr> <td data-bbox="498 911 681 1002">  </td> <td data-bbox="684 911 864 1002"> <b>5</b>  = <b>6/7</b>  <math>\cong</math> <b>T5</b>  <b>P5</b>  = <b>5</b>  <math>\cong</math> <math>\varnothing 12\text{mm}</math> </td> </tr> <tr> <td data-bbox="498 1007 681 1098">  </td> <td data-bbox="684 1007 864 1098"> <b>5</b>  = — <math>\cong</math> <b>T3</b>  <b>P3</b>  = — <math>\cong</math> <math>\varnothing 10\text{mm}</math> </td> </tr> <tr> <td data-bbox="498 1103 681 1201">  </td> <td data-bbox="684 1103 864 1201"> <b>8</b>  = — <math>\cong</math> <b>T8</b>  <b>P8</b>  = — <math>\cong</math> <math>\varnothing 15\text{mm}</math> </td> </tr> </table>		<b>A</b>  = <b>3</b>  <b>a</b>  = <b>4</b> 		<b>M</b>  = <b>2</b>  <b>P5</b>  = <b>1</b> 		<b>5</b>  = <b>6/7</b>  $\cong$ <b>T5</b> <b>P5</b>  = <b>5</b>  $\cong$ $\varnothing 12\text{mm}$		<b>5</b>  = — $\cong$ <b>T3</b> <b>P3</b>  = — $\cong$ $\varnothing 10\text{mm}$		<b>8</b>  = — $\cong$ <b>T8</b> <b>P8</b>  = — $\cong$ $\varnothing 15\text{mm}$						
	<b>A</b>  = <b>3</b>  <b>a</b>  = <b>4</b> 																
	<b>M</b>  = <b>2</b>  <b>P5</b>  = <b>1</b> 																
	<b>5</b>  = <b>6/7</b>  $\cong$ <b>T5</b> <b>P5</b>  = <b>5</b>  $\cong$ $\varnothing 12\text{mm}$																
	<b>5</b>  = — $\cong$ <b>T3</b> <b>P3</b>  = — $\cong$ $\varnothing 10\text{mm}$																
	<b>8</b>  = — $\cong$ <b>T8</b> <b>P8</b>  = — $\cong$ $\varnothing 15\text{mm}$																

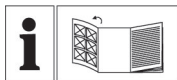

**DE** **AT** **CH**

Klappen Sie vor dem Lesen die Seite mit den Abbildungen aus und machen Sie sich anschließend mit allen Funktionen des Gerätes vertraut.

**FR** **CH**

Avant de lire le mode d'emploi, ouvrez la page contenant les illustrations et familiarisez-vous ensuite avec toutes les fonctions de l'appareil.

**IT** **CH**

Prima di leggere aprire la pagina con le immagini e prendere confidenza con le diverse funzioni dell'apparecchio.

**GB**

Before reading, unfold the page containing the illustrations and familiarise yourself with all functions of the device.

DE / AT / CH	Bedienungs- und Sicherheitshinweise	Seite	2
FR / CH	Instructions d'utilisation et consignes de sécurité	Page	5
IT / CH	Indicazioni per l'uso e per la sicurezza	Pagina	8
GB	Operation and Safety Notes	Page	11

## Inhalt

Lieferumfang.....	Seite	II
Einleitung.....	Seite	3
Bestimmungsgemäßer Gebrauch.....	Seite	3
Sicherheitshinweise.....	Seite	3
Sonstige Hinweise.....	Seite	3
Stempel wechseln.....	Seite	14
Vorbereitung des Stoffgewebes.....	Seite	16
Befestigung von Metallknöpfen.....	Seite	17
Befestigung von Kunststoffknöpfen.....	Seite	18
Reinigung und Pflege.....	Seite	3
Entsorgung.....	Seite	4
Service.....	Seite	4

## **Einleitung**

Wir beglückwünschen Sie zum Kauf Ihres neuen Produkts. Sie haben sich damit für ein hochwertiges Produkt entschieden. Die Bedienungsanleitung ist Teil dieses Produkts. Sie enthält wichtige Hinweise für Sicherheit, Gebrauch und Entsorgung.

Machen Sie sich vor der Benutzung des Produkts mit allen Bedien- und Sicherheitshinweisen vertraut. Benutzen Sie das Produkt nur wie beschrieben und für die angegebenen Einsatzbereiche. Bei einer Weitergabe des Produkts geben Sie die Gebrauchsanleitung mit.

## **Bestimmungsgemäßer Gebrauch**

Das Druckknopfzangen-Set ist ausschließlich zur Befestigung von Druckknöpfen in Stoffgeweben bis ca. 2,5 mm Dicke geeignet. Das Produkt ist nicht für den gewerblichen Einsatz oder für andere Einsatzbereiche bestimmt.

## **Sicherheitshinweise**

- Kein Spielzeug! Halten Sie Kinder von dem Produkt fern.
- Achten Sie darauf, dass Sie Ihre Finger beim Gebrauch der Zange nicht klemmen.

## **Sonstige Hinweise**

Die Druckknöpfe sind maschinenwaschbar bis 60°C. Geeignet für Stoffe bis ca. 2,5 mm Dicke (z.B. Jersey oder Fleece). Bei dünnen oder elastischen Stoffen beidseitig Vliesline zur Verstärkung einarbeiten.

## **Reinigung und Pflege**

Reinigen Sie das Produkt nur äußerlich mit einem weichen, trockenen oder leicht angefeuchteten Tuch. Verwenden Sie zum Reinigen keine scheuernden oder ätzenden Mittel bzw. Bürsten oder ähnliches.

## **Entsorgung**

Für die Entsorgung sind die örtlichen, behördlichen Vorschriften zu beachten.

Entsorgen Sie die Verpackung sortenrein in den dafür vorgesehenen Sammelbehältern.

## **Service**

Dieses Produkt unterliegt einer strengen Qualitätssicherung. Sollte dennoch ein Mangel auftreten, so bitten wir um Kontaktaufnahme mit unserem Kundendienst. Für die kostenlose Bearbeitung einer Garantieleistung ist es unbedingt erforderlich den Kaufbeleg aufzubewahren.

Qsource GmbH, Auguste-Baur-Str. 1, D-22587 Hamburg,

Tel.: 0049/40/87932653, Fax: 0049/40/87932637,

E-Mail: [service@qsource.de](mailto:service@qsource.de)

Sie erreichen uns Montag – Freitag von 8.00 – 16.00 Uhr.

## Conten

Livraison.....	Page	II
Introduction.....	Page	6
Usage prévu.....	Page	6
Sécurité.....	Page	6
Autres notes.....	Page	6
Changer de tampon.....	Page	14
Préparation du tissu.....	Page	16
Fixation des boutons en métal.....	Page	17
Fixation de boutons en plastique.....	Page	18
Nettoyage et entretien.....	Page	6
Disposition.....	Page	7
Service.....	Page	7

## Introduction

Nous vous félicitons pour l'achat de votre nouveau produit. Vous avez choisi un produit de haute qualité. Les instructions d'utilisation font partie de ce produit. Il contient des instructions importantes pour la sécurité, l'utilisation et la mise au rebut.

Avant d'utiliser le produit, familiarisez-vous avec toutes les commandes. Consignes de sécurité familières. Utilisez le produit uniquement comme décrit et pour le domaines d'application spécifiés. Lors de la distribution du produit, veuillez inclure les instructions d'utilisation.

## Usage prévu

La pince à boutons convient uniquement à la fixation de boutons-pression en tissu jusqu'à 2,5 mm d'épaisseur. Le produit n'est pas pour le commercial

Utilisez ou pour d'autres applications.

## Sécurité

- Pas de jouets! Gardez les enfants à l'écart du produit.
- Veillez à ne pas vous pincer les doigts lorsque vous utilisez la pince.

## Autres notes

Les boutons-poussoirs sont lavables en machine à 60° C.

Convient aux tissus jusqu'à 2,5 mm d'épaisseur (par exemple, jersey ou polaire). Pour les tissus minces ou élastiques, travaillez en non-tissé des deux côtés pour renforcer.

## Nettoyage et entretien

Nettoyez le produit uniquement à l'extérieur avec un chiffon doux, sec ou léger chiffon humide. N'utilisez pas d'agents abrasifs ou corrosifs, ni de brosses, etc., pour le nettoyage.



## **Disposition**

Pour l'élimination, les règlements locaux et officiels doivent être observés.

Jetez l'emballage dans les conteneurs de collecte désignés.

## **Service**

Ce produit est soumis à une assurance qualité stricte. Devrait encore être un défaut veuillez contacter notre service clientèle.

Pour le Traitement gratuit d'un service de garantie, la preuve d'achat est indispensable magasin.

Qsource GmbH, Auguste-Baur-Str. 1, D-22587 Hamburg,

tél. : 0049/40/87932653, fax 0049/40/87932637,

e-mail : [service@qsource.de](mailto:service@qsource.de)

Vous pouvez nous joindre du lundi au vendredi entre  
8 h et 16 h.

## Contenuto

Consegna.....	Pagina	II
Introduzione.....	Pagina	9
Uso previsto.....	Pagina	9
Sicurezza.....	Pagina	9
Altre note.....	Pagina	9
Cambia timbro.....	Pagina	14
Preparazione del tessuto.....	Pagina	16
Bottoni metallici di fissaggio.....	Pagina	17
Attacco di bottoni in plastica.....	Pagina	18
Pulizia e cura.....	Pagina	9
Disposizione.....	Pagina	10
Servizio.....	Pagina	10

## Introduzione

Ci congratuliamo per l'acquisto del tuo nuovo prodotto. Hai scelto un prodotto di alta qualità. Le istruzioni per l'uso fanno parte di questo prodotto. Contiene importanti istruzioni per la sicurezza, l'uso e lo smaltimento.

Prima di utilizzare il prodotto, familiarizzare con tutti i controlli Istruzioni di sicurezza familiari. Utilizzare il prodotto solo come descritto e per il specifiche aree di applicazione. Quando si distribuisce il prodotto, si prega di includere le istruzioni per l'uso.

## Uso previsto

Il set di pinze a pulsante è adatto solo per fissare bottoni automatici in tessuto fino a 2,5 mm di spessore. Il prodotto non è per lo spot.

Usa o per altre applicazioni.

## Sicurezza

- Nessun giocattolo! Tenere i bambini lontani dal prodotto.
- Fare attenzione a non schiacciarsi le dita mentre si usano le pinze..

## Altre note

I pulsanti sono lavabili in lavatrice fino a 60° C.

Adatto per tessuti fino a 2,5 mm di spessore (ad es. Jersey o pile).

Per tessuti sottili o elastici, lavorare su tessuto non tessuto su entrambi i lati per il rinforzo.

## Pulizia e cura

Pulire il prodotto solo esternamente con un panno morbido, asciutto o leggero panno inumidito Non utilizzare agenti abrasivi o corrosivi o spazzole o simili per la pulizia.

## **Disposizione**

Per lo smaltimento, è necessario osservare le normative locali locali.

Smaltire l'imballaggio ordinato nei contenitori di raccolta designati.

## **Service**

Questo prodotto è soggetto a rigorose garanzie di qualità.

Dovrebbe essere ancora un difetto si prega di contattare il nostro servizio clienti. Per il Elaborazione gratuita di un servizio di garanzia, è assolutamente necessaria la prova d'acquisto negozio.

Qsource GmbH, Auguste-Baur-Str. 1, D-22587 Amburgo,

Tel.: 0049/40/87932653, Fax 0049/40/87932637,

e-mail: [service@qsource.de](mailto:service@qsource.de)

Può contattarci da lunedì a venerdì dalle 8.00 alle 16.00.

## Content

Delivery.....	Page	11
Introduction.....	Page	12
Intended Use.....	Page	12
Safety instructions.....	Page	12
Other notes.....	Page	12
Change stamp.....	Page	14
Preparation of the fabric.....	Page	16
Fixing metal buttons.....	Page	17
Attachment of plastic buttons.....	Page	18
Cleaning and care.....	Page	12
Disposal.....	Page	13
Service.....	Page	13

## Introduction

We congratulate you on the purchase of your new product. You have chosen a high quality product. The operating instructions are part of this product. It contains important instructions for safety, use and disposal.

Before using the product, familiarize yourself with all controls Safety instructions familiar. Use the product only as described and for the specified areas of application. When hand over the product to another person, please include the instructions for use.

## Intended Use

The push-button pliers set is only suitable for fastening press studs in fabric up to 2.5 mm thick. The product is not for the commercial use or for other applications.

## Safety instructions

- No toy! Keep children away from the product.
- Be careful not to pinch your fingers while using the pliers.

## Other notes

The push buttons are machine washable up to 60° C. Suitable for fabrics up to 2.5 mm thick (for example jersey or fleece). For thin or elastic fabrics, work in non-woven fabric on both sides for reinforcement.

## Cleaning and care

Clean the product only externally with a soft, dry or light moistened cloth. Do not use abrasive or corrosive agents or brushes or the like for cleaning.

## **Disposal**

For disposal, the local, official regulations must be observed. Dispose of the packaging sorted in the designated collection containers..

## **Service**

This product is subject to strict quality assurance. Should still be a defect please contact our customer service. For the free processing of a warranty service, it is absolutely necessary the proof of purchase store.

Qsource GmbH, Auguste-Baur-Str. 1, D-22587 Hamburg,

Tel. +49-40-87932653, Fax +49-40-87932637,

E-Mail: [service@qsource.de](mailto:service@qsource.de)

You can reach us Monday to Friday from 8:00 AM to 4:00 PM.

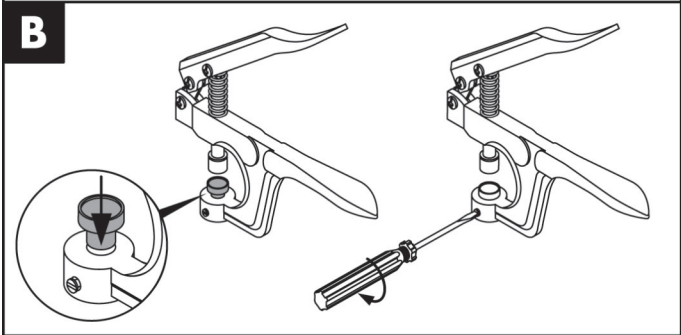
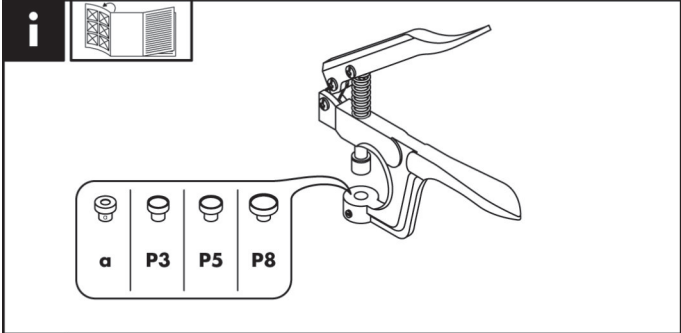
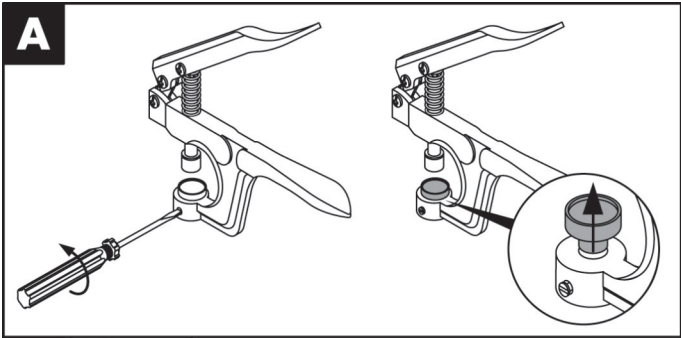

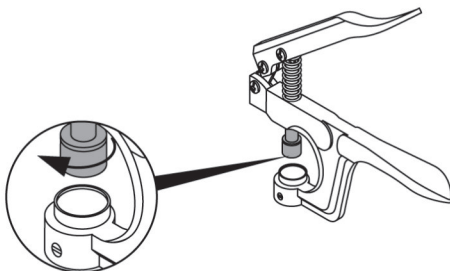
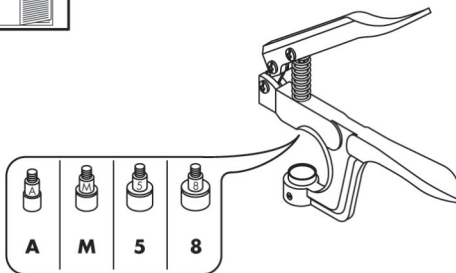
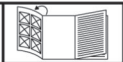
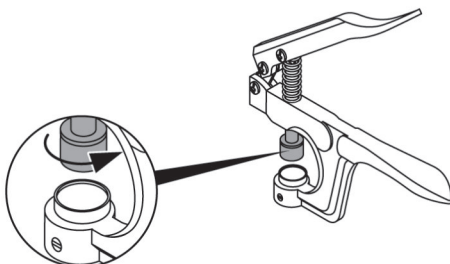

**C****i****D**



DE / AT / CH

Gehen Sie sorgfältig vor. Druckknöpfe können nicht zerstörungsfrei versetzt werden.

FR / CH

Soyez prudent. Les boutons-poussoirs ne peuvent pas être déplacés de manière non destructive.

IT / CH

Stai attento. I pulsanti non possono essere spostati in modo distruttivo.

GB

Be careful. Push buttons cannot be moved non-destructively.

**E**

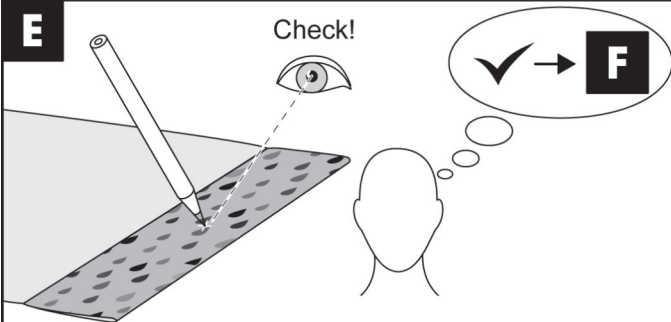

**F**

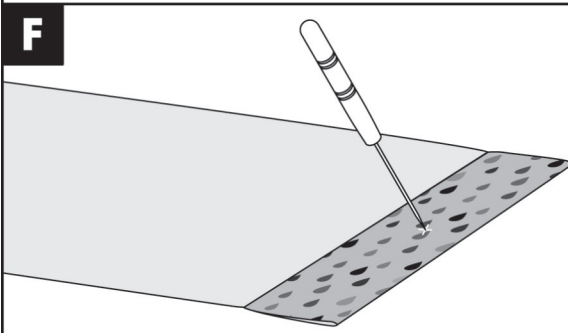

**i**

**G**

**H**

Metall  
Metal  
Métal  
Metallo

**G**

1



2

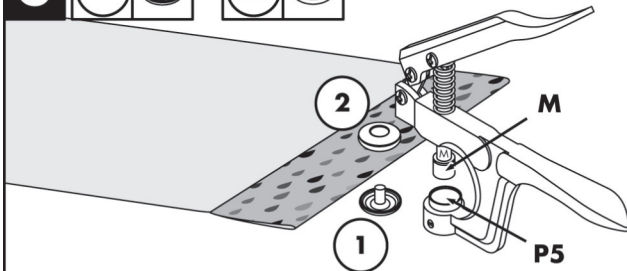

**H**

3



4

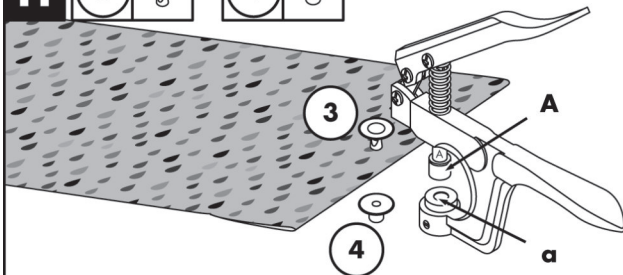

**i**

**I**

**J**

Kunststoff  
Plastic  
Plastique  
Plastica

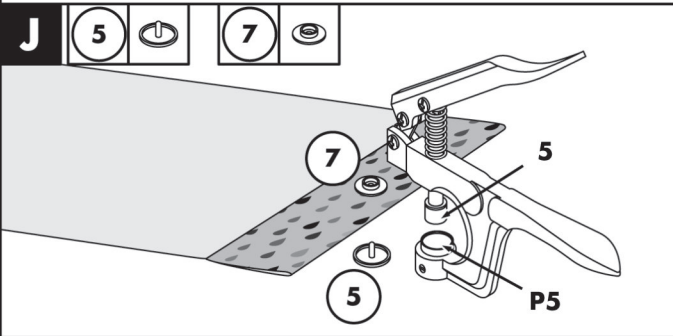
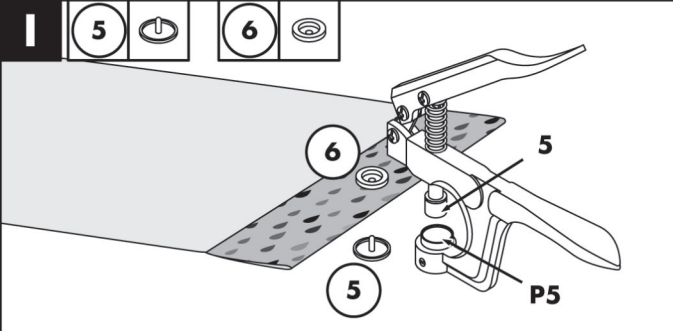

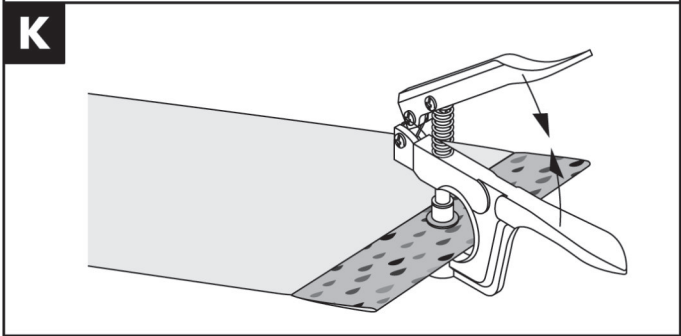
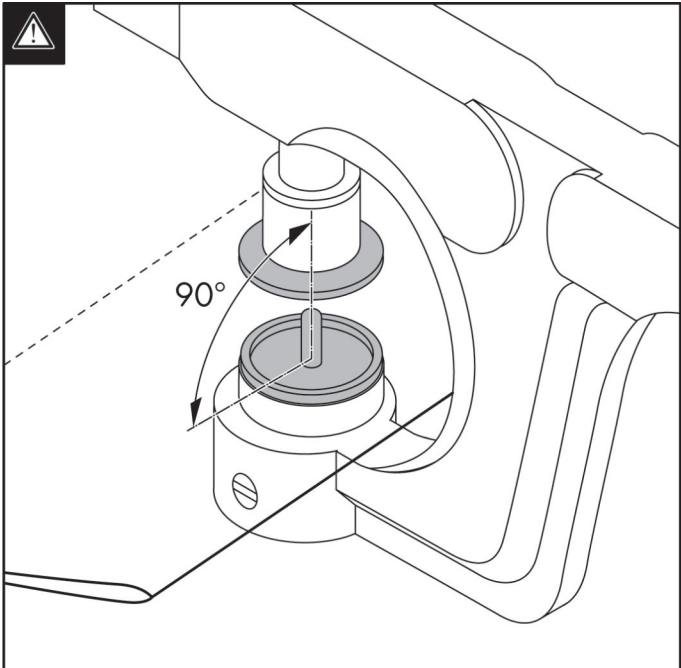

QSOURCE GMBH  
Auguste Baur Straße 1  
22587 Hamburg  
GERMANY  
E-Mail: [service@qsource.de](mailto:service@qsource.de)  
Fon: +49 40 87932653  
Fax: +49 40 87932637

Stand der Informationen · Version des informations  
Versione delle informazioni · Last information Update:  
12 / 2020  
Ident.-No.: QSD2020L01354162\_2010

---

IAN 354162\_2010

