



BLUETOOTH®-ON-EAR-KOPFHÖRER RHYTHM/RHYTHM BLUETOOTH® ON-EAR HEADPHONES/CASQUE BLUETOOTH® SUPRA-AURICULAIRE RHYTHM RHYTHM ON-EAR ANC

DE AT CH

BLUETOOTH®-ON-EAR-KOPFHÖRER RHYTHM

Kurzanleitung

FR BE

CASQUE BLUETOOTH® SUPRA-AURICULAIRE RHYTHM

Guide de démarrage rapide

PL

SŁUCHAWKI NAUSZNE BLUETOOTH® RHYTHM

Krótka instrukcja

SK

SLÚCHADLÁ ON-EAR BLUETOOTH®

Krátky návod

DK

BLUETOOTH® ON-EAR HØRETELEFONER RHYTHM

Kort vejledning

HU

BLUETOOTH®-ON-EAR FEJHALLGATÓ RHYTHM

Rövid útmutató

GB IE

RHYTHM BLUETOOTH® ON-EAR HEADPHONES

Quick start guide

NL BE

BLUETOOTH®-ON-EAR HOOFDTELEFOON RHYTHM

Korte handleiding

CZ

SLUCHÁTKA BLUETOOTH® RHYTHM

Krátký návod

ES

AAURICULARES DE DIADEMA BLUETOOTH® RHYTHM

Guía rápida

IT

CUFFIE BLUETOOTH® ON-EAR RHYTHM







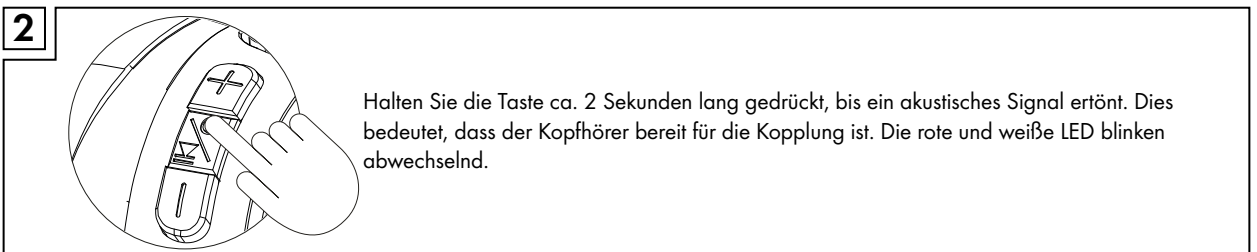
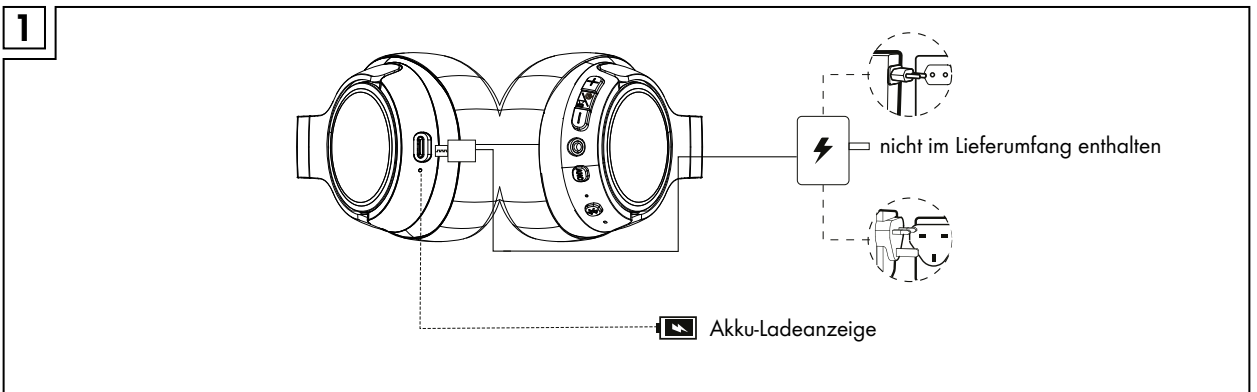
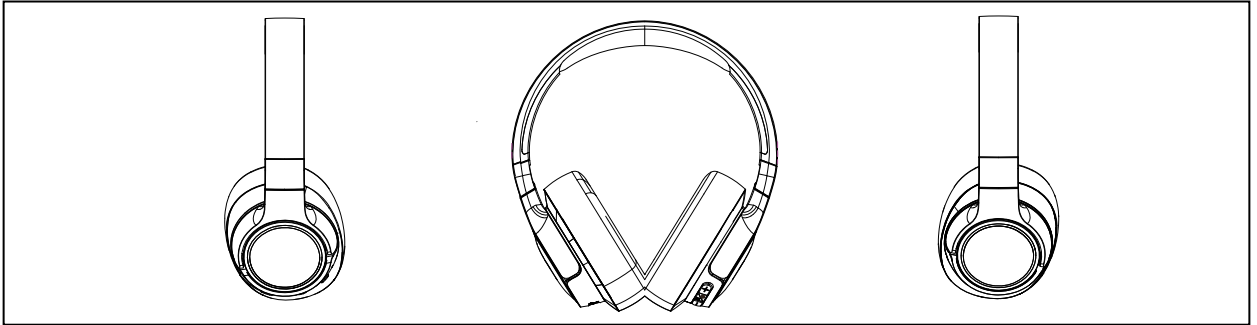

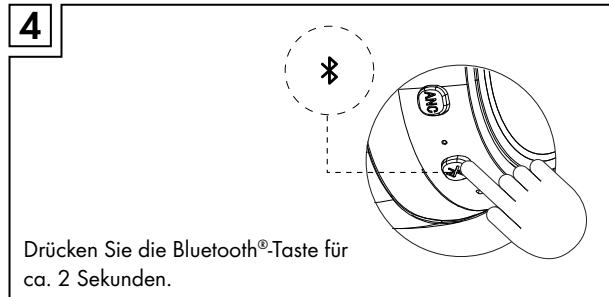
Guida rapida

DE/AT/CH	Kurzanleitung	Seite	3
GB/IE	Quick start guide	Page	5
FR/BE	Guide de démarrage rapide	Page	7
NL/BE	Korte handleiding	Pagina	9
PL	Krótka instrukcja	Strona	11
CZ	Stručný návod	Strana	13
SK	Krátky návod	Strana	15
ES	Guía rápida	Página	17
DK	Kort vejledning	Side	19
IT	Guida rapida	Pagina	21
HU	Rövid útmutató	Oldal	23

Diese Kurzanleitung ist fester Bestandteil der Bedienungsanleitung. Bewahren Sie diese zusammen mit der Bedienungsanleitung gut auf. Händigen Sie alle Unterlagen bei Weitergabe des Produkts an Dritte mit aus. Lesen Sie vor der Verwendung die Bedienungsanleitung und beachten Sie insbesondere die darin enthaltenen Sicherheitshinweise.





LED-Status	LED-Verhalten
 Bereit für den Pairing Modus	 Rot und Weiß Rotes und weißes LED-Licht blinken abwechselnd.
 Pairing-Modus	 Weiß Die weiße LED blinkt einmal alle 5 Sekunden.
 Akku lädt	 Rot LED leuchtet durchgehend rot.
 Akku vollgeladen	 Rot Rote LED aus.

This quick reference guide is a fixed part of the operating instructions. Keep both this and the operating instructions in a safe place. When passing this product on to third parties, please be sure to include all documentation. Read the operating instructions before use, and pay particular attention to the safety instructions included in the operating instructions.

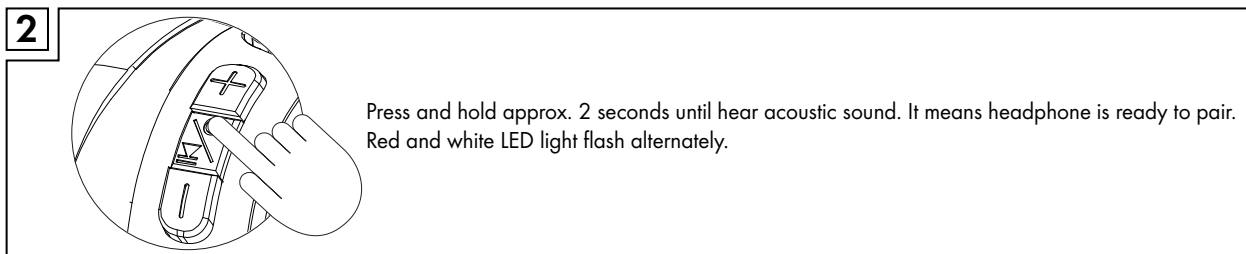
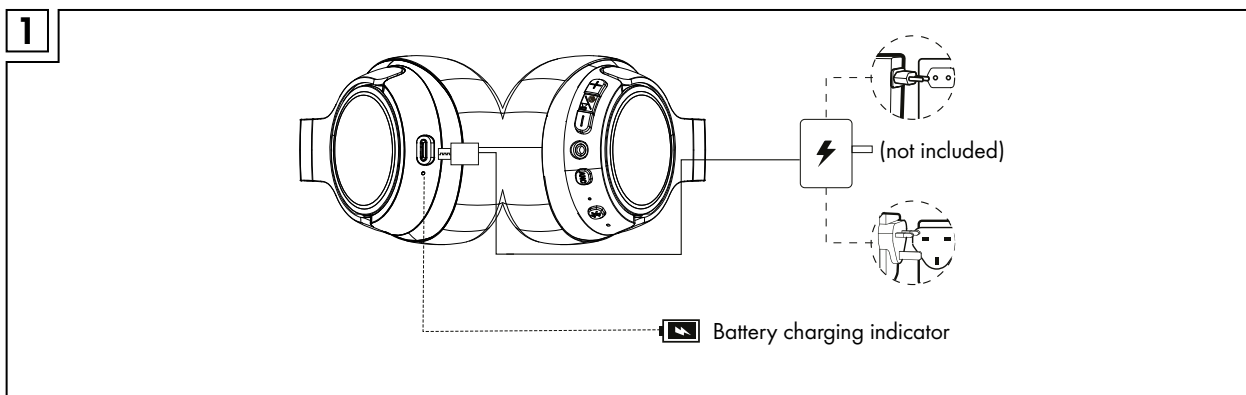
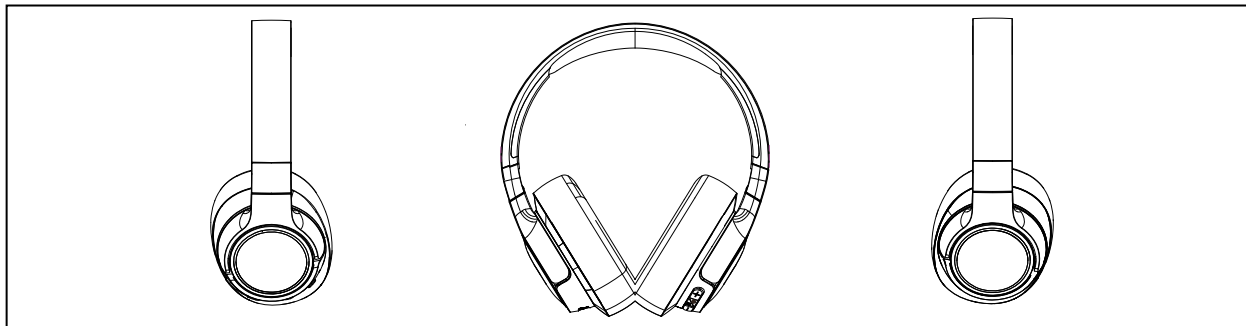









3

Select "Rhythm On-Ear ANC" from the list of communication device and confirm the connecting.

4

Press Bluetooth® button for approx. 2 seconds.

LED-Status	LED Behaviors
 Ready for pairing mode	 Red and White Red and White LED light flash alternately.
 Paired mode	 White The White LED flashes every 5 seconds.
 Battery charging	 Red Red solid LED ON.
 Battery fully charged	 Red Red LED OFF.

Ce guide rapide fait partie intégrante du mode d'emploi. Conservez-le soigneusement avec le mode d'emploi. Lorsque vous remettez le produit à d'autres utilisateurs, veuillez également leur transmettre tous les documents liés à celui-ci. Lisez avant l'utilisation le mode d'emploi et respectez tout particulièrement les consignes de sécurité qui y figurent.

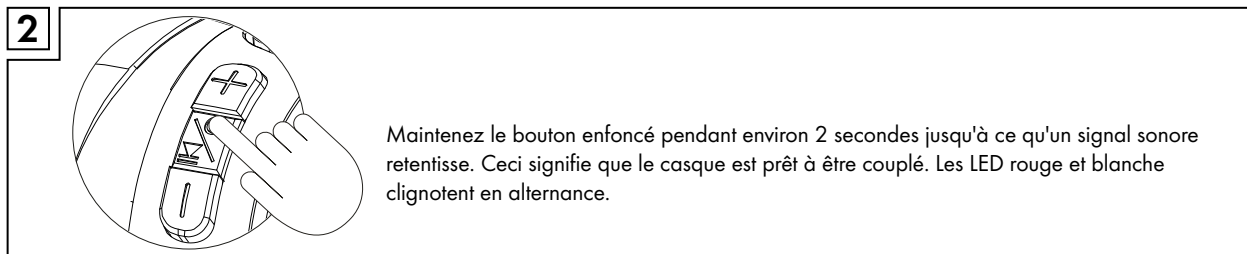
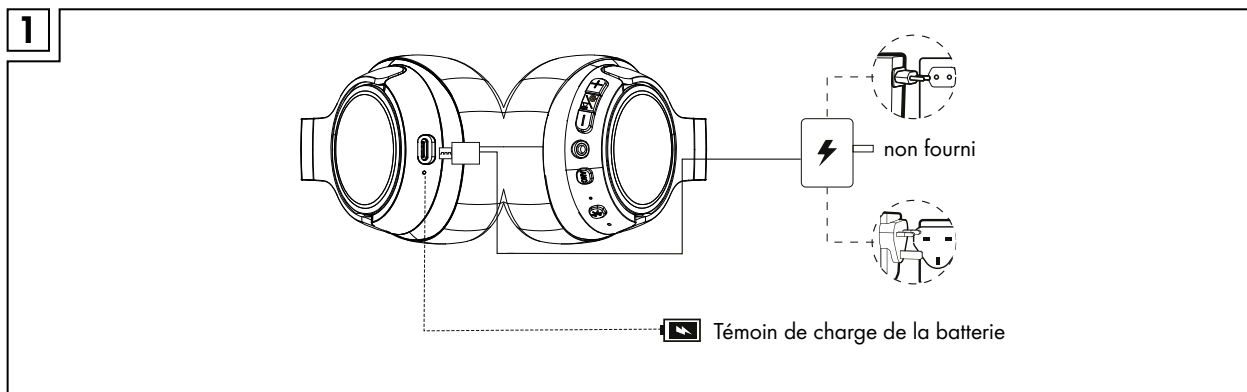
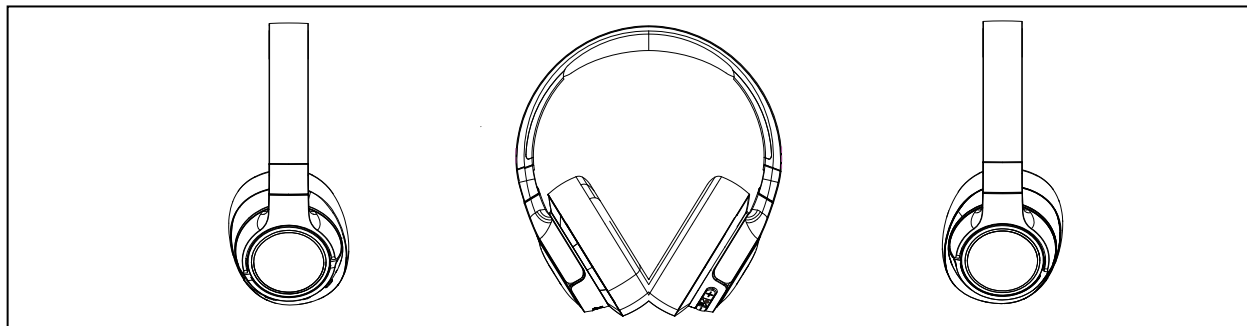

3

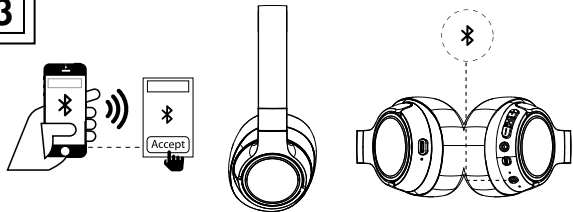

Sélectionnez « Rhythm On-Ear ANC » dans la liste des appareils de communication et confirmez la connexion.

4

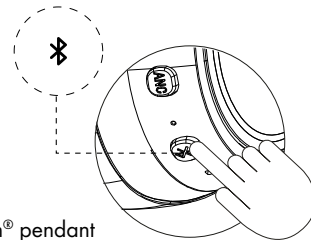

Pressez le bouton Bluetooth® pendant env. 2 secondes.

Statut des LED



Prêt pour le mode d'appairage



Mode d'appairage



La batterie se charge



Batterie entièrement chargée

Comportement des LED



Rouge et blanc

Les lumières LED rouge et blanche clignotent en alternance.



Blanc

La LED blanche clignote une fois toutes les 5 secondes.



Rouge

La LED s'allume en rouge de manière continue.



Rouge

LED rouge éteinte.

Deze beknopte handleiding is vast bestanddeel van de gebruiksaanwijzing. Bewaar hem samen met de gebruiksaanwijzing goed. Overhandig alle documenten bij doorgifte van het product aan derden. Lees voor het gebruik de gebruiksaanwijzing en neem in het bijzonder de hierin vermelde veiligheidsvoorschriften in acht.

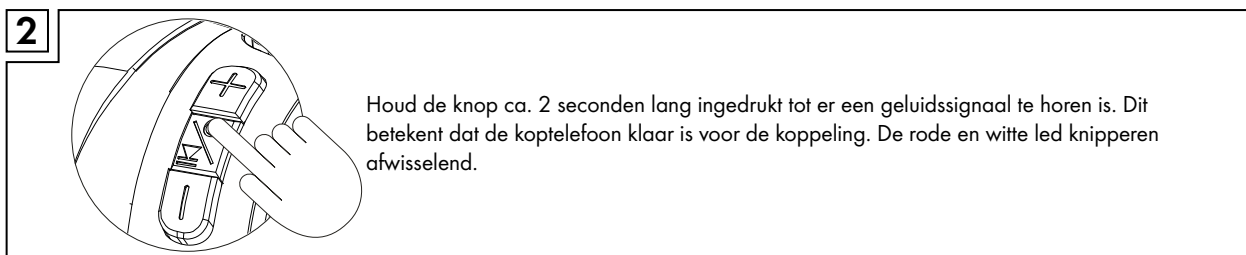
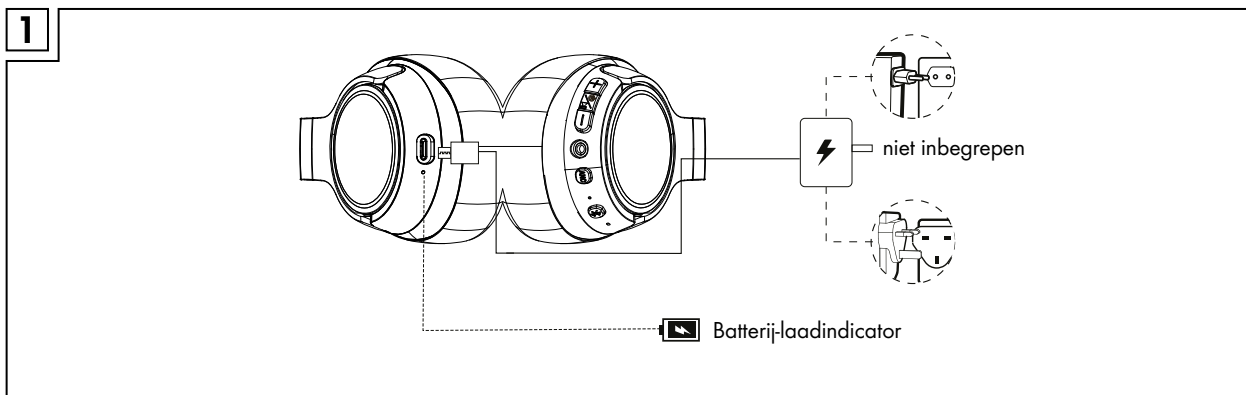
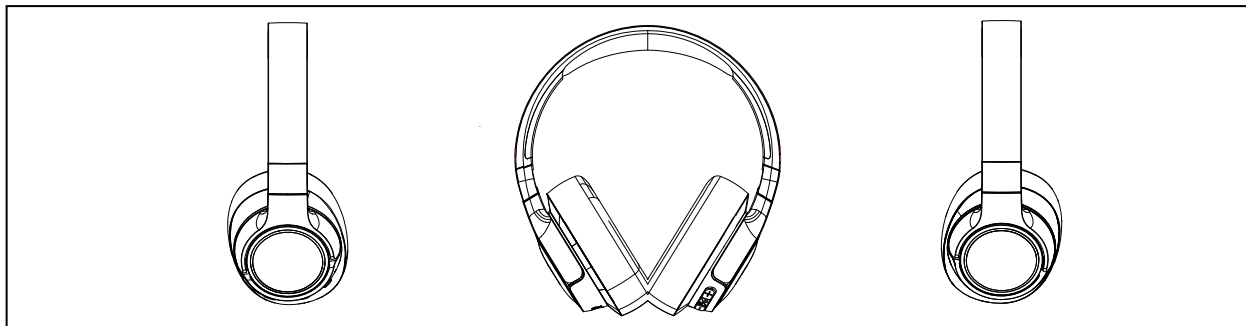

3

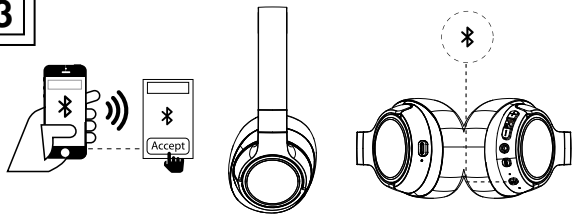





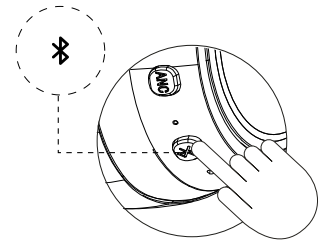



Selecteer 'Rhythm On-Ear ANC' uit de lijst met communicatie-apparaten en bevestig de verbinding.

4



Druk ca. 2 seconden op de Bluetooth®-knop.

Led-status	Led-weergave
 Klaar voor de pairing-modus	 Rood en wit Het rode en witte led-lampje knipperen afwisselend.
 Pairing-modus	 Wit De witte led knippert eenmaal elke 5 seconden.
 Batterij wordt opgeladen	 Rood De led brandt continu rood.
 Batterij opgeladen	 Rood Rode led uit.

Ta krótka instrukcja obsługi jest stałą częścią składową instrukcji obsługi. Należy ją zachować wraz z instrukcją obsługi. W przypadku przekazania produktu innej osobie należy dołączyć do niego całą jego dokumentację. Przed użyciem należy przeczytać instrukcję obsługi i szczególnie przestrzegać zawartych w niej wskazówek dotyczących bezpieczeństwa.

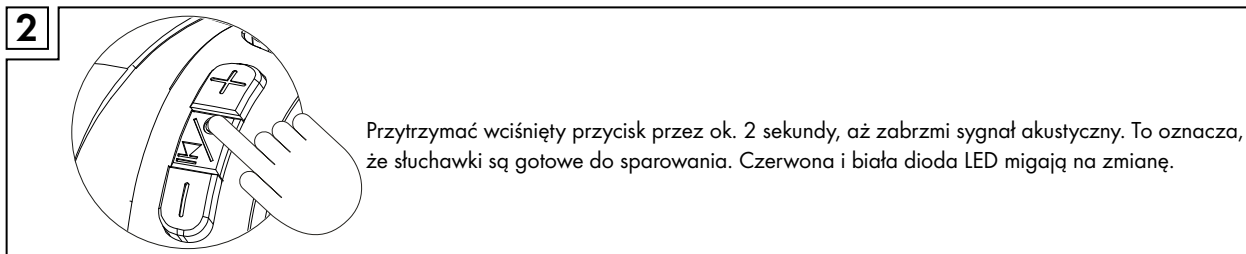
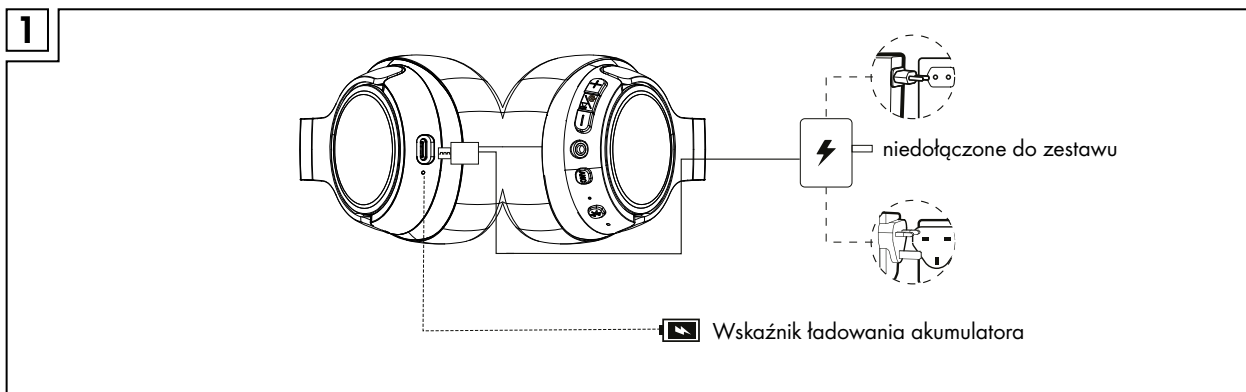
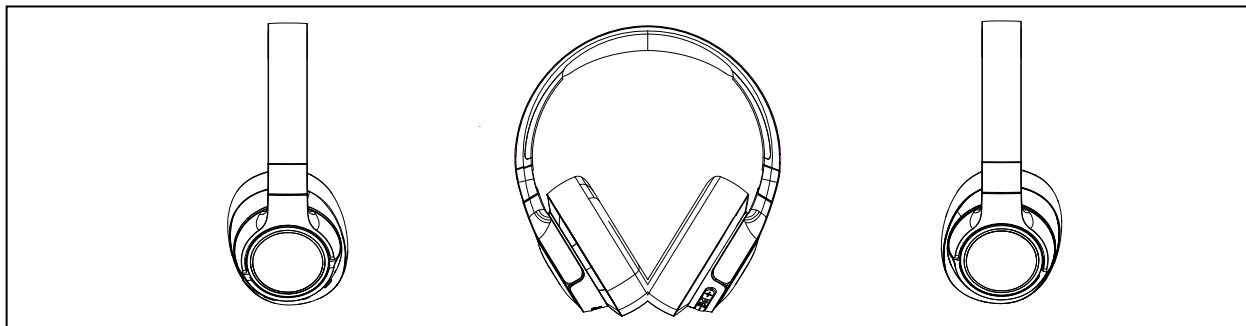

3

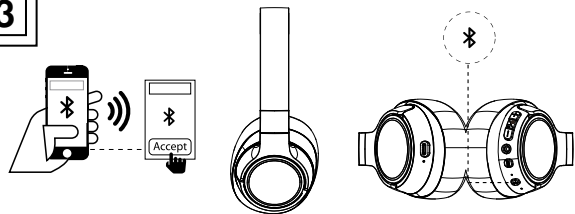

Wybrać „Rhythm On-Ear ANC” z listy urządzeń do komunikacji i potwierdzić połączenie.

4

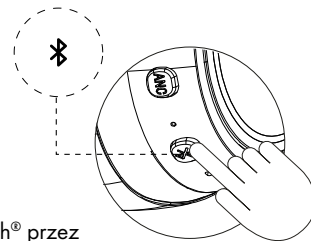

Nacisnąć przycisk Bluetooth® przez ok. 2 sekundy.

Status LED



Gotowe do trybu parowania



Tryb parowania



Akumulator ładuje się.



Akumulator w pełni naładowany.

Zachowanie LED



Czerwona i biała

Czerwona i biała dioda LED migają na zmianę.



Biała

Biała dioda LED miga raz co 5 sekund.



Czerwona

Dioda LED świeci stale na czerwono.









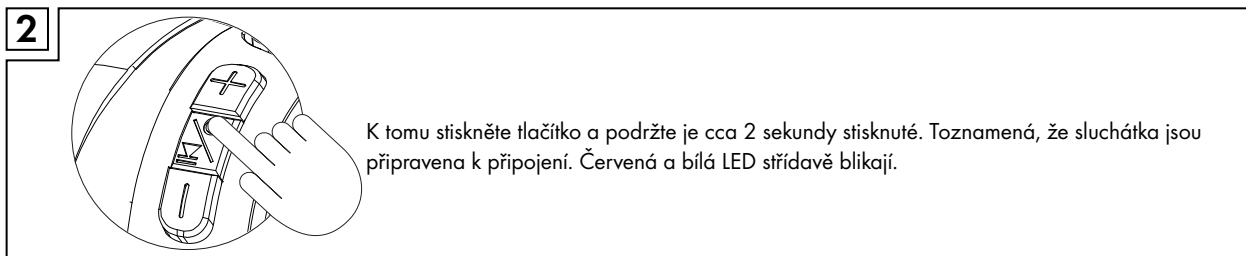
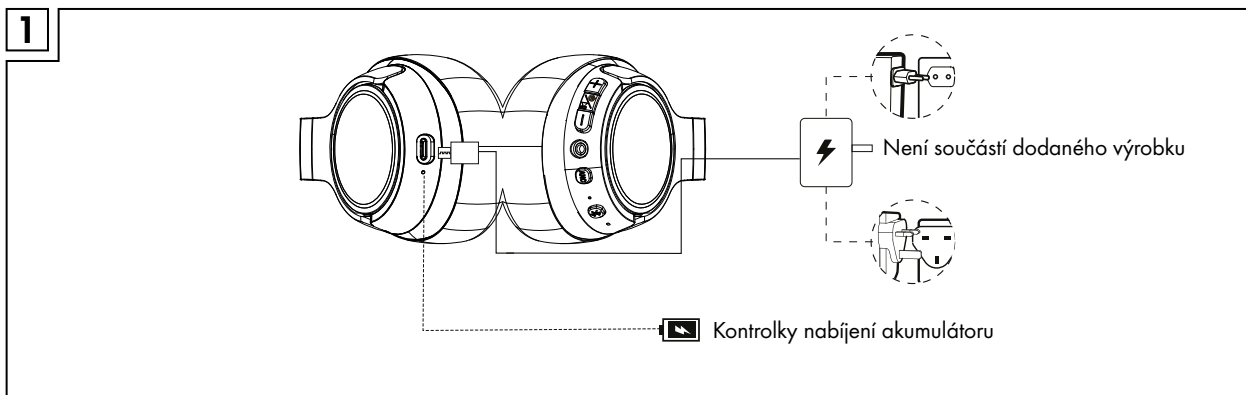
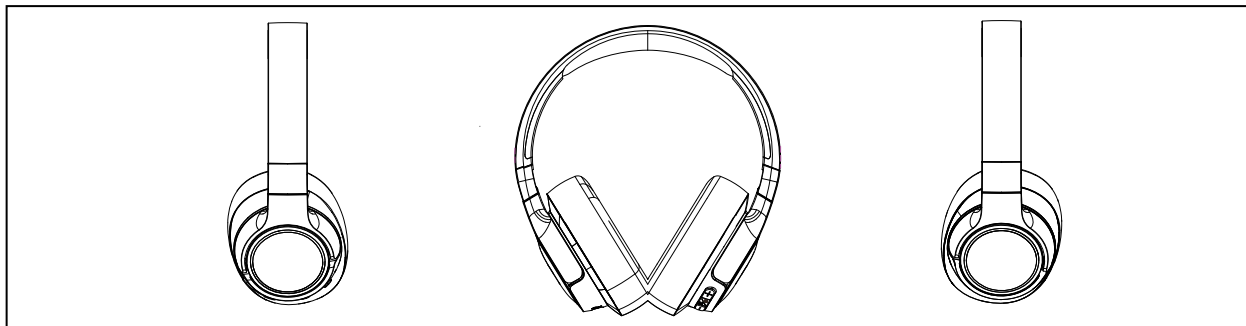

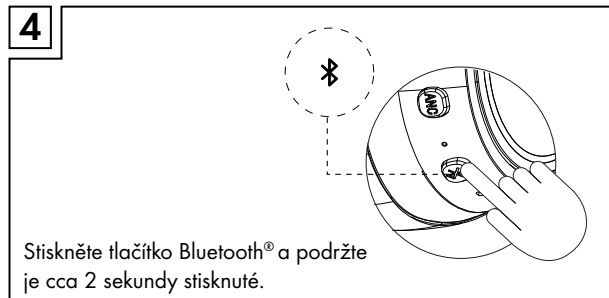
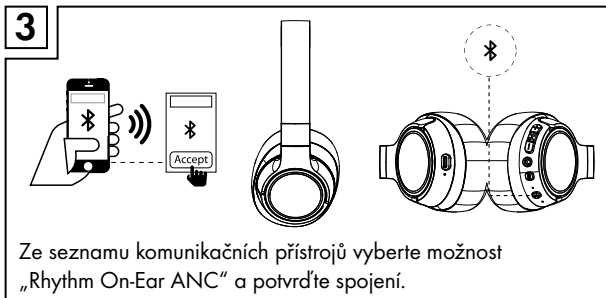
Czerwona

Czerwona dioda LED wyłączona

Tento stručný návod je nedílnou součástí návodu k obsluze. Uložte jej společně s návodem k obsluze. Při předávání výrobku třetí osobě současně předávejte i všechny související podklady. Před použitím si přečtěte návod k obsluze a dodržujte především bezpečnostní předpisy, které jsou v něm obsaženy.









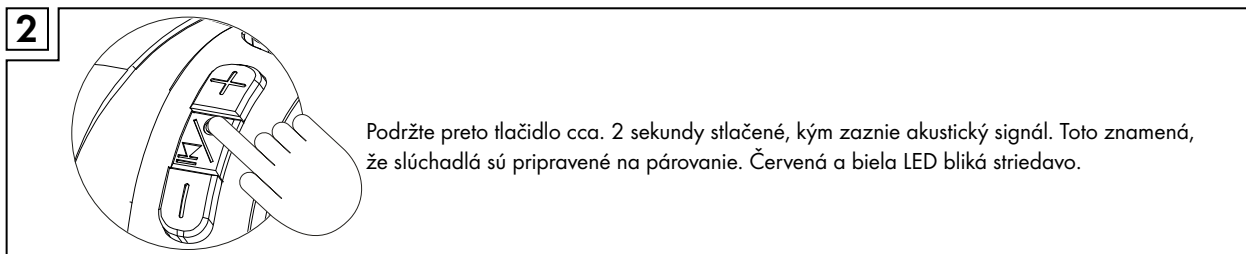
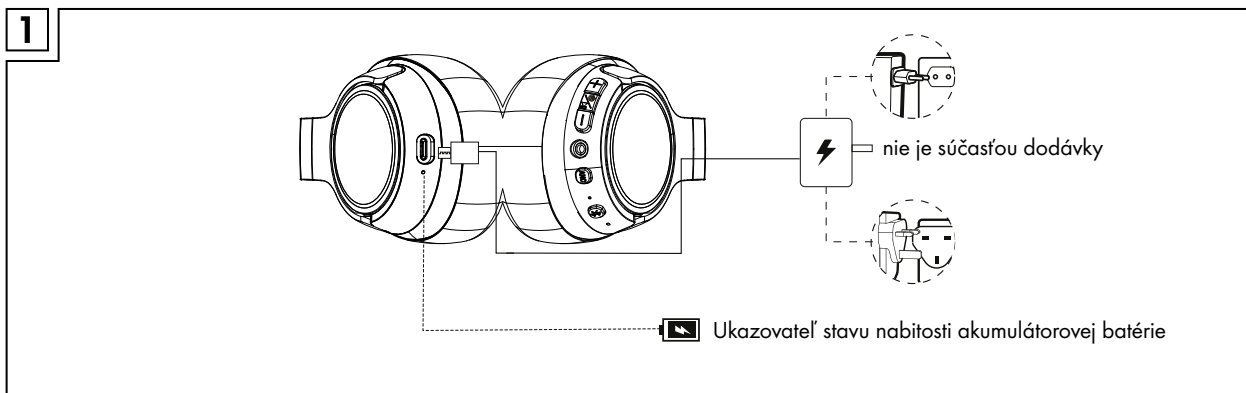
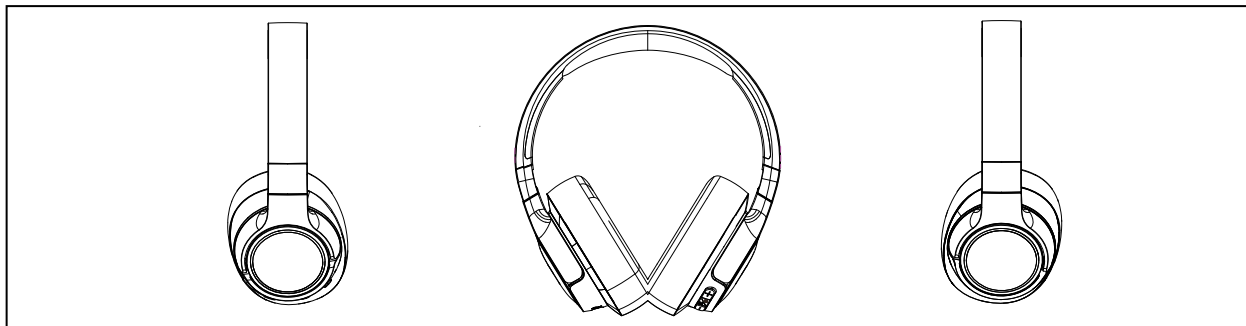

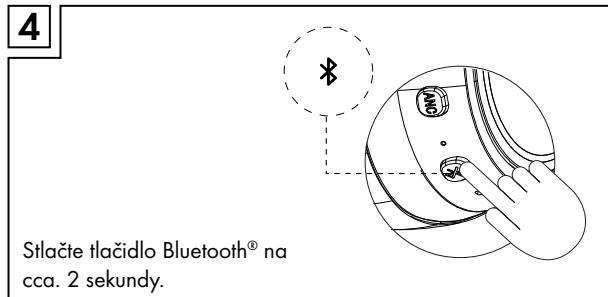

Stav LED	Reakce LED
 Připraveno na režim párování	 Červená a bílá Červená a bílá LED střídavě blikají.
 Režim párování	 Bílá Bílá LED bliká jednou za 5 sekund.
 Probíhá nabíjení akumulátoru	 Červená LED trvale svítí červeně.
 Akumulátor je plně nabitý.	 Červená Červená LED zhasne.

Tento krátky návod je pevnou súčasťou návodu na obsluhu. Dobre ho uschovajte spolu s návodom na obsluhu. Ak odovzdávate výrobok ďalšej osobe, priložte k nemu aj všetky podklady. Pred používaním si pozorne prečítajte návod na obsluhu a dodržiavajte najmä v ňom uvedené bezpečnostné pokyny.









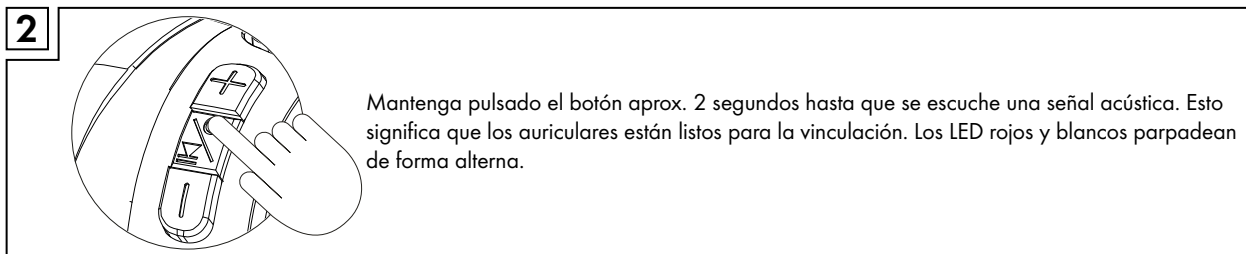
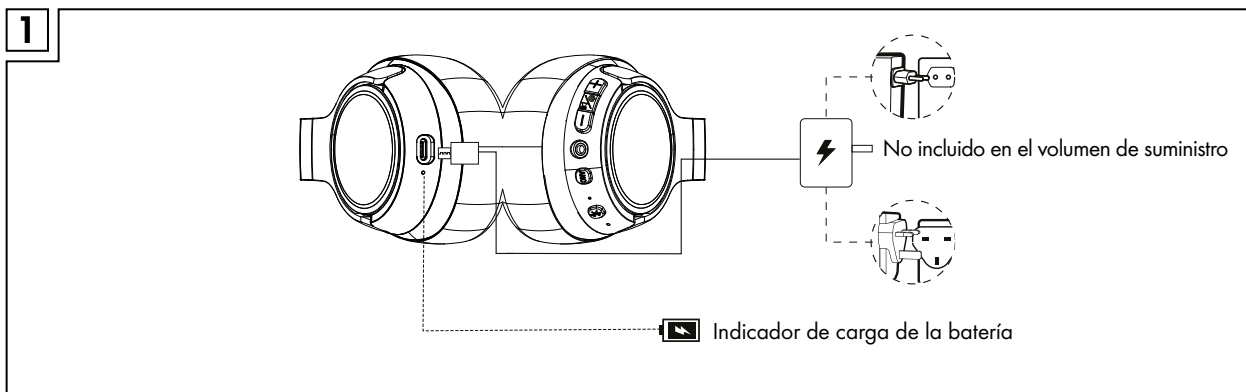
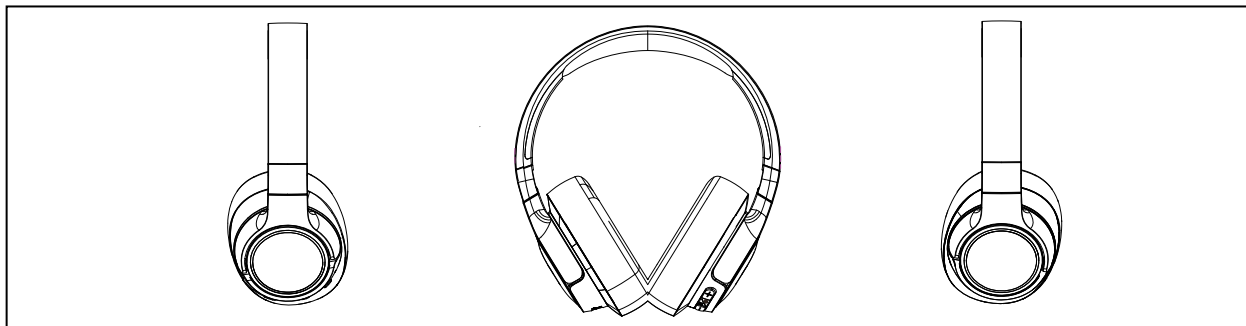

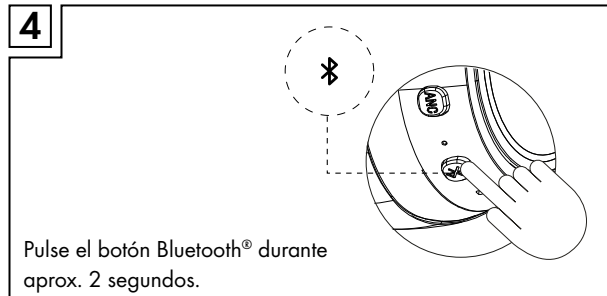

LED status	LED správanie
 Pripravené pre párovací režim	 Červená a biela Striedavo bliká červené a biele LED svetlo.
 Párovací režim	 Biela Biela LED zabliká každých 5 sekúnd.
 Akumulátorová batéria sa nabíja	 Červená LED nepretržite svieti červeno.
 Akumulátorová batéria je plne nabitá	 Červená Červená LED je vypnutá.

Esta guía breve forma parte del manual de instrucciones. Guárdela adecuadamente junto con el manual de instrucciones. Adjunte igualmente toda la documentación en caso de entregar el producto a terceros. Antes de comenzar a utilizar el producto, lea el manual de instrucciones y cumpla especialmente las indicaciones de seguridad incluidas.









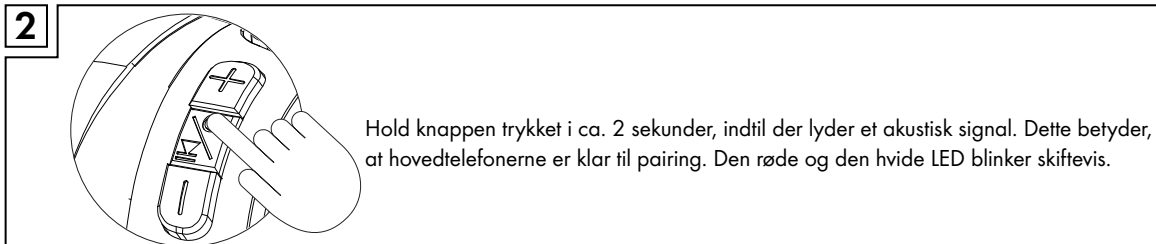
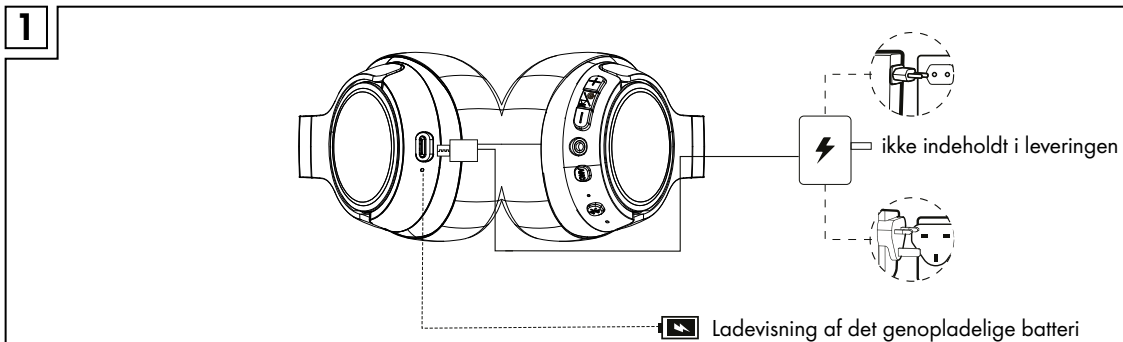
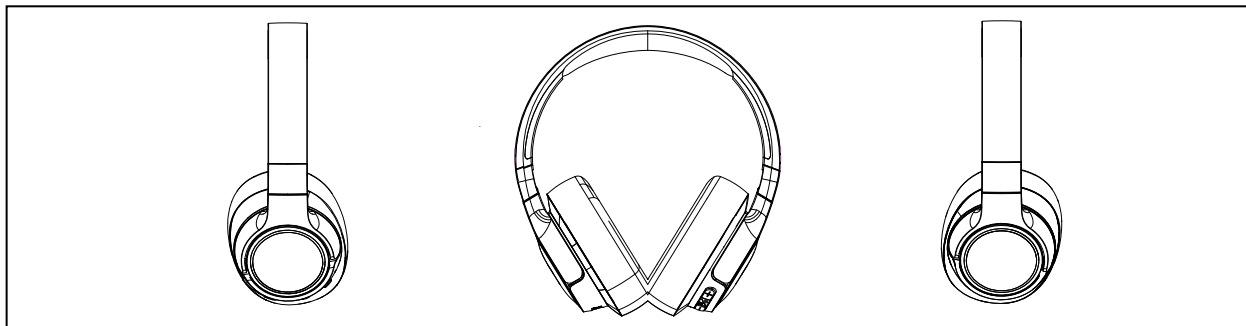

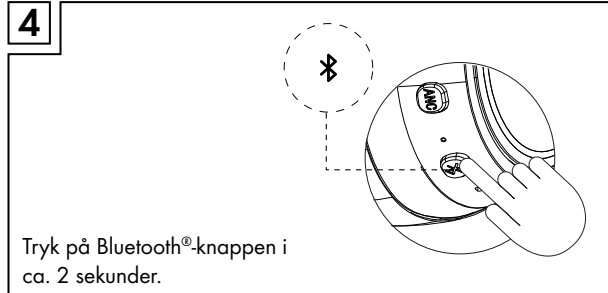

LED de estado	Comportamiento de los LED
 Listo para el modo de sincronización	 Rojo y blanco Los LED de color rojo y blanco parpadean de forma alterna.
 Modo de sincronización	 Blanco El LED blanco parpadea una vez cada 5 segundos.
 La batería está cargando	 Rojo El LED se ilumina de manera constante en rojo.
 Batería con carga completa	 Rojo LED rojo apagado.

Denne korte vejledning er del af betjeningsvejledningen. Opbevar den omhyggeligt sammen med betjeningsvejledningen. Udlever ved videregivelse af produktet alle bilag til tredjemand. Læs denne betjeningsvejledning grundig igennem inden anvendelsen og vær især opmærksom på sikkerhedshenvisningerne i betjeningsvejledningen.





LED-status	LED-adfærd
 Klar til pairing-tilstand	 Rød og hvid Den røde og den hvide LED blinker skiftevis.
 Pairing-tilstand	 Hvid Den hvide LED blinker en gang alle 5 sekunder.
 Batteri oplader	 Rød LED'en lyser konstant rødt.
 Batteri helt opladet	 Rød Rød LED slukket.

Questa guida rapida è parte integrante delle istruzioni per l'uso. Conservarla con cura insieme alle istruzioni per l'uso. In caso di cessione del prodotto a terzi consegnare anche tutta la documentazione. Prima dell'utilizzo leggere le istruzioni per l'uso e seguire in particolare le avvertenze per la sicurezza ivi contenute.

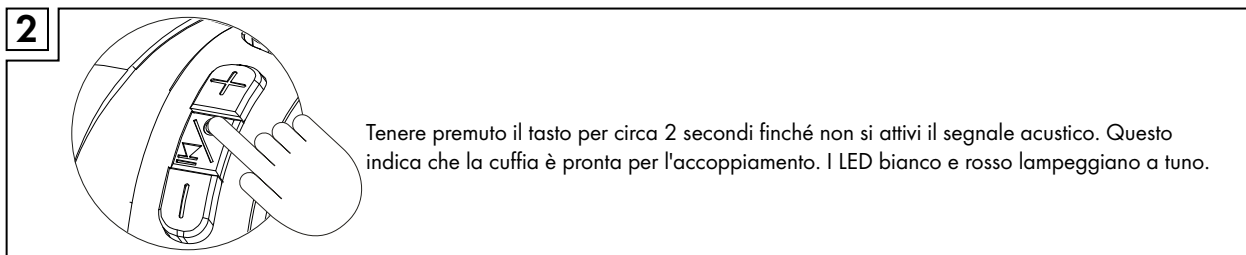
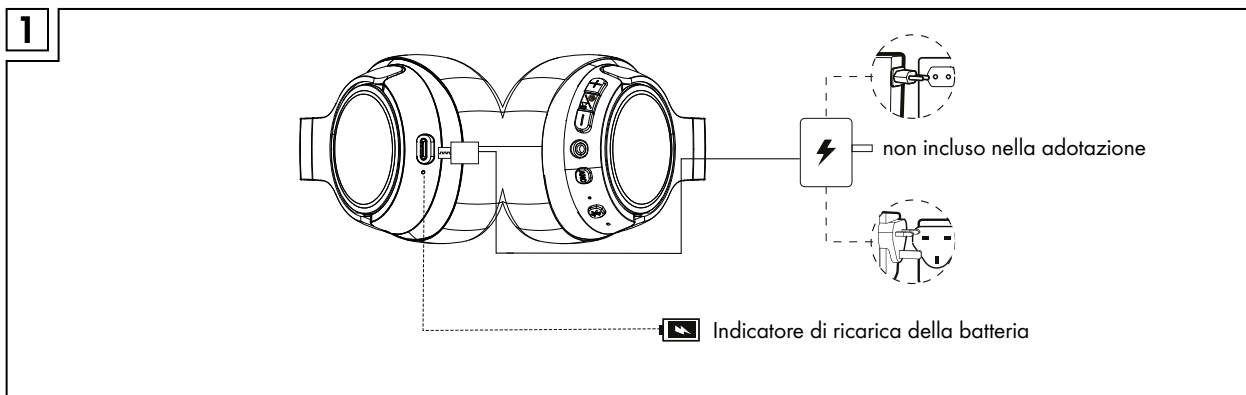
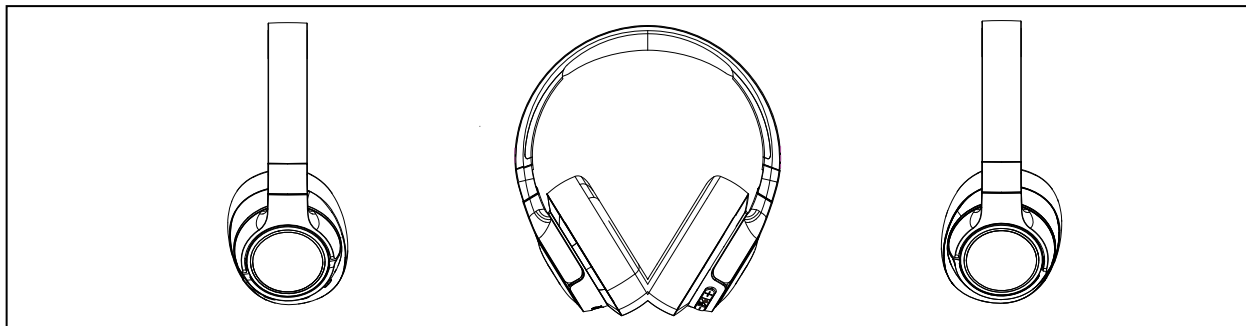

3







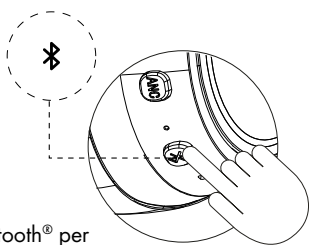



Selezionare "Rhythm On-Ear ANC" sulla lista dei dispositivi di comunicazione e confermare il collegamento.

4









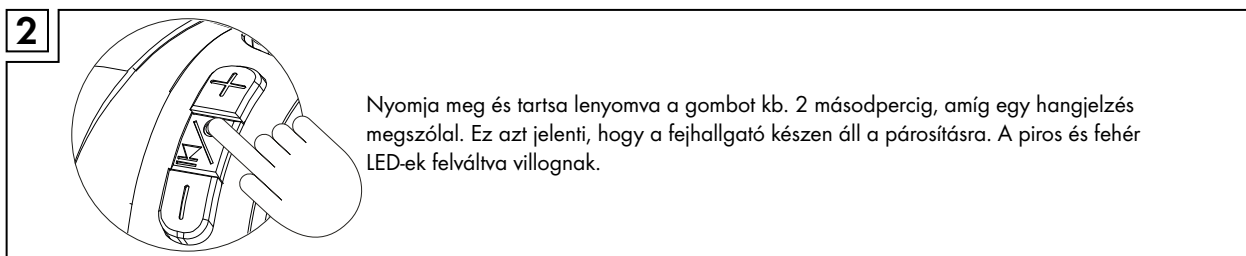
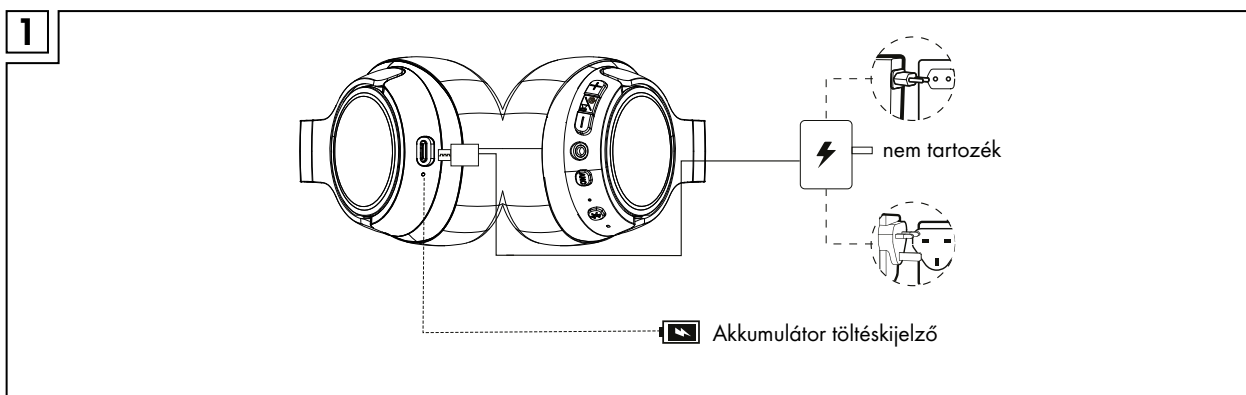
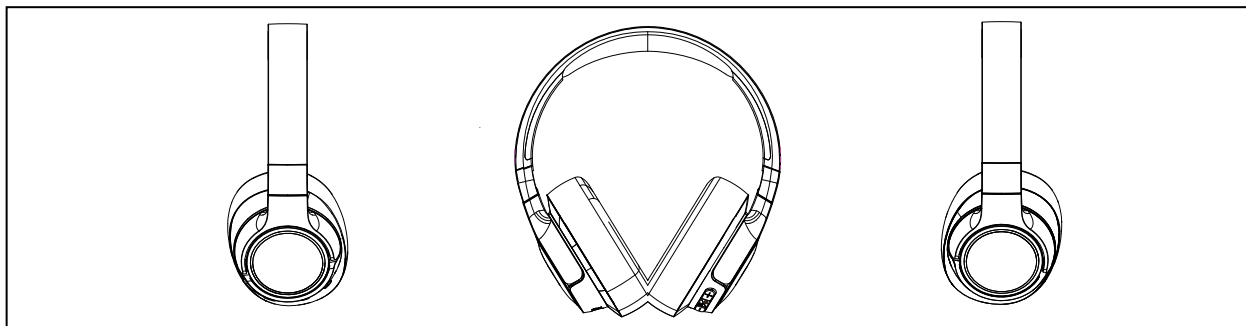

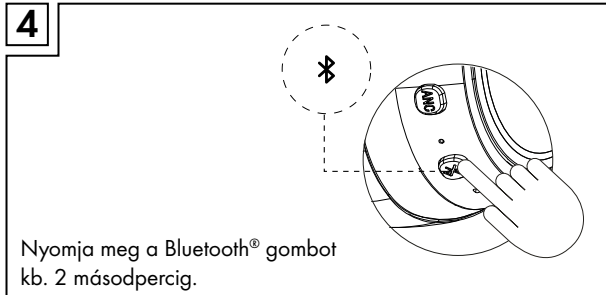
Tenere premuto il tasto Bluetooth® per circa 2 secondi.

Stato del LED	Comportamento del LED
 Pronto per la modalità Pairing	 Rosso e bianco I LED bianco e rosso lampeggiano a turno.
 Modalità di accoppiamento	 Bianco Il LED bianco lampeggia una volta ogni 5 secondi.
 La batteria è in carica	 Rosso Il LED emette una luce rossa fissa.
 Batteria completamente carica	 Rosso Il LED rosso è spento.

Ez a rövid útmutató a használati utasítás fontos része. Gondosan őrizze meg a használati utasítással együtt. A termék harmadik félnek történő továbbadása esetén adja át a teljes dokumentációt is. Használat előtt olvassa el a használati utasítást és különösen az abban olvasható biztonsági tudnivalókat tartsa szem előtt.





LED-állapot	LED-kapcsolódás
 Készen áll a párosítás üzemmódra	 Piros és fehér A piros és fehér LED-fények felváltva villognak.
 Párosítás üzemmód	 Fehér A fehér LED 5 másodpercenként egyszer villog.
 Az akkumulátor töltődik	 Piros A LED folyamatosan pirosan világít.
 Az akkumulátor teljesen feltöltött.	 Piros A piros LED kialszik.

OWIM GmbH & Co. KG

Stiftsbergstraße 1
74167 Neckarsulm
GERMANY

Model no.: HG10599

Version: 11/2023

Stand der Informationen · Last Information
Update · Version des informations · Stand
van de informatie · Stan informacj · Stav
informací · Stav informácií · Estado de las
informaciones · Tilstand af information
Versione delle informazioni · Információk
állása · Stanje informacij; 09/2023
Ident.-No.: HG10599092023-8

IAN 439253_2304