



## CORDLESS BOOK LIGHT

GB IE  
**CORDLESS BOOK LIGHT**  
Operation and safety notes

CZ  
**AKU LAMPIČKA NA ČTENÍ**  
Pokyny pro obsluhu a bezpečnostní pokyny

IAN 384757\_2110

CZ

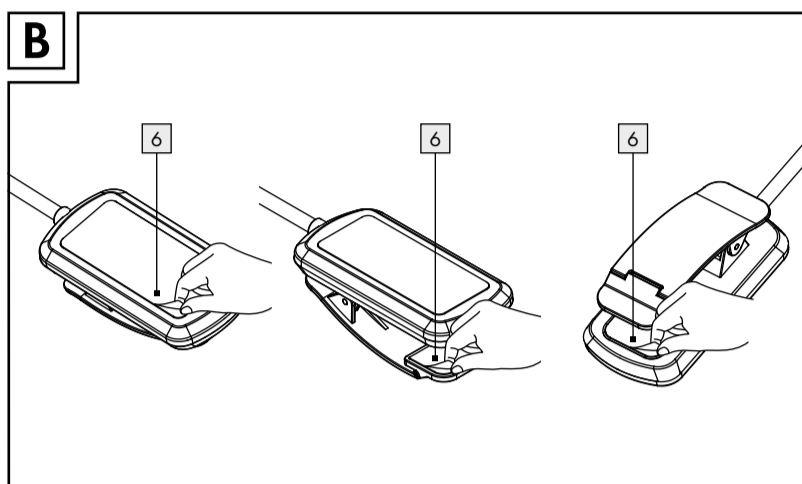
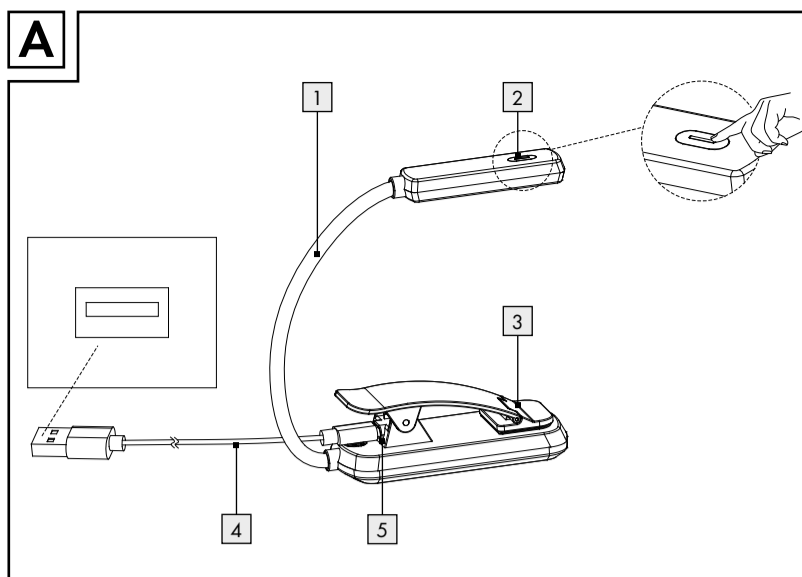

### List of pictograms used

	Please read the operating instructions!		Danger of explosion!
	This light is only suitable for indoor use in dry and enclosed spaces.		Wear safety gloves!
<b>SELV</b>	Safety extra low voltage		For your safety
<b>V</b>	Volt		Dispose of the packaging and product in an environmentally-friendly manner!
<b>Hz</b>	Hertz (frequency)	<b>25000h</b>	Operating life
<b>IP20</b>	For indoor use only		Warning! Risk of electric shock
	Observe the warnings and safety notices!		USB port
	Danger to life and risk of accidents for infants and children!		The packaging is made from 100% recycled paper.
	Environmental damage through incorrect disposal of the batteries/rechargeable batteries!		

### Cordless Book Light

#### Introduction

Please be sure to carefully read the complete instructions for use. These instructions are part of the product and contain important information on setup and handling. Always follow all safety instructions. Before using this product for the first time verify the correct voltage and that all parts are properly installed. If you have any questions or you are unsure about operating the product, please contact the distributor or service centre. Please keep these instructions in a safe place and pass them on to third parties if necessary.

#### Intended use

This luminaire is only suitable for indoor use, in dry and enclosed rooms. This device is only intended for use in a private domestic environment, not for commercial use. Any use other than that described above is prohibited and will result in product damage. It is further associated with dangers, e.g. short circuit, fire, electric shock, etc. This product is intended for normal operation.

#### Scope of delivery

Check immediately after unpacking that the parts are complete and that the product is in proper condition.

- 1 rechargeable book light (14164005L)
- 1 USB charging cable (without adapter)
- 1 set of instructions for use

#### Parts description

- Flexible lamp arm with lamp head
- On/off button
- Clamp with soft pads
- USB cable
- LED charging light
- Protective foil

#### Technical data

**Light:**  
Model number: 14164005L  
Rated power: max. 1.9W  
Illuminant: LED module  
Rechargeable battery:  
1 x 3.7V; 500 mAh  
USB input: SELV 5V=  
Protection class: III/  
IP rating: IP20  
Charging time: approx. 2.5 h

Light on time: approx. 5 h (strong light)/  
approx. 10 h (weak light)

**LED module:**  
Rated power: max. 0.45 W

#### Safety

##### Safety instructions

Damage due to failure to comply with these instructions for use will void the warranty! We assume no liability for consequential damages! We assume no liability for property damage or personal injury due to improper handling or failure to comply with the safety instructions!

##### **WARNING! RISK OF FATAL INJURY AND ACCIDENT HAZARD FOR TODDLERS AND SMALL CHILDREN!**

- Never leave children unsupervised with the packaging material. The packaging material poses a suffocation hazard. Children frequently underestimate the dangers. Please always keep the product out of the reach of children.
- This device may be used by children aged 8 years and up, as well as by persons with reduced physical, sensory or mental capacities, or lacking experience and/or knowledge, so long as

they are supervised or instructed in the safe use of the device and understand the associated risks. Do not allow children to play with the product. Cleaning and user maintenance must not be performed by children without supervision.

##### **Avoid the risk of fatal injury from electric shock**

- Check the rechargeable book light for possible damage before every use. Never use the rechargeable book light if it shows any signs of damage.
- WARNING!** A damaged USB cable represents the danger of death from electric shock. In the case of damage, repairs or other problems, please contact the service centre or a qualified electrician.
- Before use, verify that the available mains voltage corresponds with the required operating voltage of the item (see "Technical data").
- Never allow the live power leads and contacts to come into contact with water or other liquids.
- Never open any of the electrical equipment or insert objects into it. Such interferences pose a risk of fatal injury from electric shock.
- Do not use the rechargeable book light if it is covered with objects or is inlaid into a surface.
- Do not install the light on damp or conductive surfaces.

- Always unplug the USB cable from the USB port before assembly, disassembly or cleaning.
- Never touch the USB cable or rechargeable book light with wet hands.
- Only use the individual parts supplied, otherwise all warranty claims will become invalid.
- Never connect the rechargeable book light to the power supply while it is in the packaging. Remove the item from the packaging before you connect it to a USB port.

##### **Prevent fire and injury hazards**

- This product does not contain any parts that can be serviced by the user.
- Do not look into the LED from a close distance during operation.
- Do not look at the LED with an optical instrument (e.g. magnifying glass).
- Fully charge the rechargeable book light before first use.
- Do not charge the rechargeable book light overnight.
- The product's illuminant is not replaceable. The entire light needs to be replaced if the illuminant reaches the end of its service life.
- Do not install the rechargeable book light near flammable materials.
- When attaching the rechargeable book light, make sure that none of your

- extremities are between the clamp and the surface on which it is standing.
- This product is a reading light. Do not use this light as a night light.
- If the USB cable is damaged, it may only be replaced with a cable that is available from the manufacturer or customer services centre.

##### **For your safety**

- Install the rechargeable book light so that it is protected from dirt and excessive heat.
- Always be alert! Always pay attention to what you are doing and always use common sense. Never use the rechargeable book light if you are having difficulty concentrating or do not feel well.
- Familiarise yourself with all instructions and diagrams in this manual as well as with the rechargeable book light itself before use.

##### **Safety instructions for batteries/rechargeable batteries**

- DANGER TO LIFE!** Keep batteries/rechargeable batteries out of reach of children. If accidentally swallowed seek immediate medical attention.

GB/IE

GB/IE

GB/IE

##### **DANGER OF EXPLOSION!**

- Never recharge non-rechargeable batteries. Do not short-circuit batteries/rechargeable batteries and/or open them. Overheating, fire or bursting can be the result.
- Never throw batteries/rechargeable batteries into fire or water.
- Do not exert mechanical loads to batteries/rechargeable batteries.

##### **Risk of leakage of batteries/rechargeable batteries**

- Avoid extreme environmental conditions and temperatures, which could affect batteries/rechargeable batteries, e.g. radiators/direct sunlight.
- If batteries/rechargeable batteries have leaked, avoid contact with skin, eyes and mucous membranes with the chemicals! Flush immediately the affected areas with fresh water and seek medical attention!

##### **WEAR PROTECTIVE GLOVES!**

- Leaked or damaged batteries/rechargeable batteries can cause burns on contact with the skin. Wear suitable protective gloves at all times if such an event occurs.
- This product has a built-in rechargeable battery which cannot be replaced by the user.

#### Before first use

##### Charging the rechargeable book light

**Note:** Remove all packaging material from the product and the protective films [6] from the surfaces.

- Connect the USB cable [4] to the light (see Fig. A).
- Connect the USB plug to a suitable USB port, e.g. plug-in adapter, computer, etc. During charging, the LED charging light [5] on the clamp [3] lights up red.
- Allow the light to charge fully. When charging is complete, the LED charging light [5] on the clamp [3] lights up blue.
- Remove the USB cable [4] from the USB port and from the light.

#### Prior to first use

##### Attaching the rechargeable book light

- Make sure to attach the light to a stable surface which can withstand the weight of the light (e.g. book, monitor, laptop). The light is not suitable for attaching to pipes or poles.
- Open the clamp [3] by pushing both ends of the clamp [3] together.
- Slide the opened clamp [3] fully onto the chosen surface and release both ends of the clamp [3] slowly so that it closes.

- Use the flexible lamp arm [1] to adjust the lamp head as desired. Be sure to use a firm grip on the clamp [3] when doing so.

Your light is now ready to use.

##### Switching the rechargeable book light on/off and dimming (see Fig. B)

- To switch the light on, press the on/off button [2] on the lamp head.
- Press the on/off button [2] again to choose between the different light temperatures:  
**1 x press:** light switches on (neutral white light)  
**2 x press:** cold white light  
**3 x press:** warm white light  
**4 x press:** light switches off
- To dim the light, hold the on/off button [2] pressed down.

#### Maintenance and cleaning

##### **WARNING! DANGER TO LIFE FROM ELECTRIC SHOCK!**

- Before performing any work, first disconnect the light from the mains power. Unplug the USB cable [4] from the USB port.
- Do not use solvents, petrol, etc. These would damage the light.
- Clean the lamp with a dry, lint-free cloth.

#### Disposal

The packaging is made entirely of recyclable materials, which you may dispose of at local recycling facilities.

Observe the marking of the packaging materials for waste separation, which are marked with abbreviations (a) and numbers (b) with following meaning: 1-7: plastics/20-22: paper and fibreboard/80-98: composite materials.

To help protect the environment, please dispose of the product properly when it has reached the end of its useful life and not in the household waste. Information on collection points and their opening hours can be obtained from your local authority.

Faulty or used batteries/rechargeable batteries must be recycled in accordance with Directive 2006/66/EC and its amendments. Please return the batteries/rechargeable batteries and/or the product to the available collection points.

##### **Environmental damage through incorrect disposal of the batteries/rechargeable batteries!**

Batteries/rechargeable batteries may not be disposed of with the usual domestic waste. They may contain toxic heavy metals and are subject to hazardous waste treatment rules and regulations. The chemical symbols for heavy metals are as follows: Cd = cadmium, Hg = mercury, Pb = lead. That is why you should dispose of used batteries/rechargeable batteries at a local collection point.

##### Removing the rechargeable battery

- The rechargeable battery must be disconnected from the light before disposal. To do this, proceed as follows:
  - Remove the anti-slip pad on the bottom of the clamp [3].
  - Unscrew the screw on the bottom of the clamp [3] using a screwdriver.
  - Remove the bottom of the clamp [3].
  - Carefully separate the connection wires from the light to the rechargeable battery.
  - Then remove the rechargeable battery.

#### Warranty and service

##### Warranty

You receive a 36 month warranty on this product, valid from the date of purchase. The appliance has been carefully produced under strict quality control. Within the warranty period we shall rectify without charge all material and manufacturing defects. In the event of a defect during the warranty period, please send the appliance to the listed Service Centre address, referencing the following model number: 14164005L. Wear parts (such as bulbs) and damage caused by improper handling, non-observance of the operating instructions or unauthorised interference are excluded from the warranty. The performance of services under the warranty does not extend or renew the warranty period.

##### Service address

Briloner Leuchten GmbH & Co. KG  
Im Kissen 2  
59929 Brilon  
GERMANY  
Tel.: +49 29 61/97 12-800  
Fax: +49 29 61/97 12-199  
E-Mail: kundenservice@briloner.com  
www.briloner.com

GB/IE

GB/IE

GB/IE

