



## MINI FOOTBALL TABLE

<b>GB</b>	<b>MINI FOOTBALL TABLE</b> <div>Instructions for use</div>	<b>HU</b>	<b>MINI CSOCSÓ</b> <div>Használati útmutató</div>
-----------	--	-----------	---

<b>SI</b>	<b>MINI NAMIZNI NOGOMET</b> <div>Navodila za uporabo</div>	<b>CZ</b>	<b>STOLNÍ MINI FOTBAL</b> <div>Návod k použití</div>
-----------	--	-----------	--

<b>SK</b>	<b>STOLNÝ MINIFUTBAL</b> <div>Návod na používanie</div>	<b>DE</b> <b>AT</b> <b>CH</b>	<b>MINI TISCHFUSSBALL</b> <div>Gebruiksaanweisung</div>
-----------	---	-------------------------------	---

<b>HU</b>	<b>SI</b>	<b>CZ</b>	<b>SK</b>
-----------	-----------	-----------	-----------

<b>HU</b>	<b>SI</b>	<b>CZ</b>	<b>SK</b>
-----------	-----------	-----------	-----------

<b>HU</b>	<b>SI</b>	<b>CZ</b>	<b>SK</b>
-----------	-----------	-----------	-----------

<b>HU</b>	<b>SI</b>	<b>CZ</b>	<b>SK</b>
-----------	-----------	-----------	-----------

<b>HU</b>	<b>SI</b>	<b>CZ</b>	<b>SK</b>
-----------	-----------	-----------	-----------

<b>HU</b>	<b>SI</b>	<b>CZ</b>	<b>SK</b>
-----------	-----------	-----------	-----------

<b>HU</b>	<b>SI</b>	<b>CZ</b>	<b>SK</b>
-----------	-----------	-----------	-----------

<b>HU</b>	<b>SI</b>	<b>CZ</b>	<b>SK</b>
-----------	-----------	-----------	-----------

<b>HU</b>	<b>SI</b>	<b>CZ</b>	<b>SK</b>
-----------	-----------	-----------	-----------

<b>HU</b>	<b>SI</b>	<b>CZ</b>	<b>SK</b>
-----------	-----------	-----------	-----------

<b>HU</b>	<b>SI</b>	<b>CZ</b>	<b>SK</b>
-----------	-----------	-----------	-----------

<b>HU</b>	<b>SI</b>	<b>CZ</b>	<b>SK</b>
-----------	-----------	-----------	-----------

<b>HU</b>	<b>SI</b>	<b>CZ</b>	<b>SK</b>
-----------	-----------	-----------	-----------

<b>HU</b>	<b>SI</b>	<b>CZ</b>	<b>SK</b>
-----------	-----------	-----------	-----------

<b>HU</b>	<b>SI</b>	<b>CZ</b>	<b>SK</b>
-----------	-----------	-----------	-----------

<b>HU</b>	<b>SI</b>	<b>CZ</b>	<b>SK</b>
-----------	-----------	-----------	-----------

<b>HU</b>	<b>SI</b>	<b>CZ</b>	<b>SK</b>
-----------	-----------	-----------	-----------

<b>HU</b>	<b>SI</b>	<b>CZ</b>	<b>SK</b>
-----------	-----------	-----------	-----------

<b>HU</b>	<b>SI</b>	<b>CZ</b>	<b>SK</b>
-----------	-----------	-----------	-----------

<b>HU</b>	<b>SI</b>	<b>CZ</b>	<b>SK</b>
-----------	-----------	-----------	-----------

<b>HU</b>	<b>SI</b>	<b>CZ</b>	<b>SK</b>
-----------	-----------	-----------	-----------

<b>HU</b>	<b>SI</b>	<b>CZ</b>	<b>SK</b>
-----------	-----------	-----------	-----------

<b>HU</b>	<b>SI</b>	<b>CZ</b>	<b>SK</b>
-----------	-----------	-----------	-----------

<b>HU</b>	<b>SI</b>	<b>CZ</b>	<b>SK</b>
-----------	-----------	-----------	-----------

<b>HU</b>	<b>SI</b>	<b>CZ</b>	<b>SK</b>
-----------	-----------	-----------	-----------

<b>HU</b>	<b>SI</b>	<b>CZ</b>	<b>SK</b>
-----------	-----------	-----------	-----------

<b>HU</b>	<b>SI</b>	<b>CZ</b>	<b>SK</b>
-----------	-----------	-----------	-----------

<b>HU</b>	<b>SI</b>	<b>CZ</b>	<b>SK</b>
-----------	-----------	-----------	-----------

<b>HU</b>	<b>SI</b>	<b>CZ</b>	<b>SK</b>
-----------	-----------	-----------	-----------

<b>HU</b>	<b>SI</b>	<b>CZ</b>	<b>SK</b>
-----------	-----------	-----------	-----------

<b>HU</b>	<b>SI</b>	<b>CZ</b>	<b>SK</b>
-----------	-----------	-----------	-----------

<b>HU</b>	<b>SI</b>	<b>CZ</b>	<b>SK</b>
-----------	-----------	-----------	-----------

<b>HU</b>	<b>SI</b>	<b>CZ</b>	<b>SK</b>
-----------	-----------	-----------	-----------

<b>HU</b>	<b>SI</b>	<b>CZ</b>	<b>SK</b>
-----------	-----------	-----------	-----------

<b>HU</b>	<b>SI</b>	<b>CZ</b>	<b>SK</b>
-----------	-----------	-----------	-----------

<b>HU</b>	<b>SI</b>	<b>CZ</b>	<b>SK</b>
-----------	-----------	-----------	-----------

<b>HU</b>	<b>SI</b>	<b>CZ</b>	<b>SK</b>
-----------	-----------	-----------	-----------

<b>HU</b>	<b>SI</b>	<b>CZ</b>	<b>SK</b>
-----------	-----------	-----------	-----------

<b>HU</b>	<b>SI</b>	<b>CZ</b>	<b>SK</b>
-----------	-----------	-----------	-----------

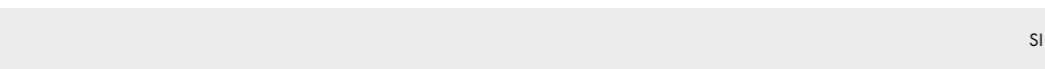
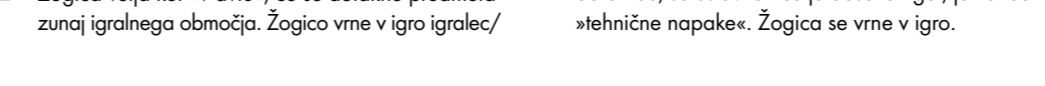
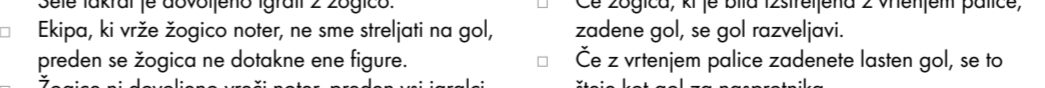
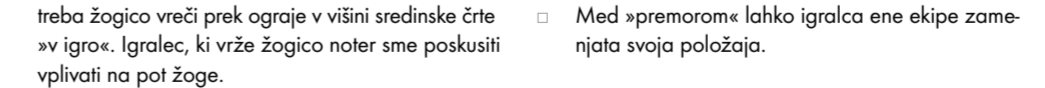
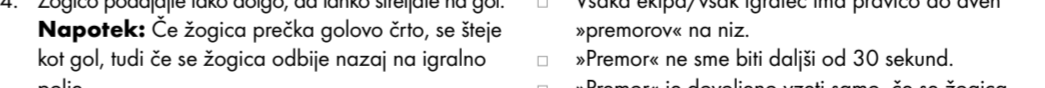
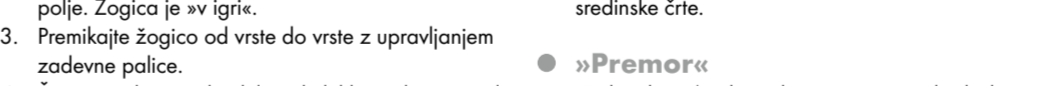
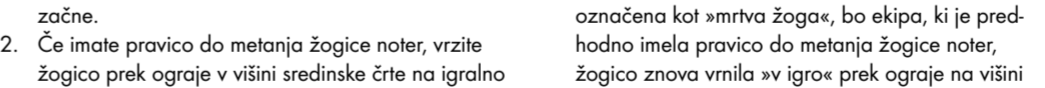
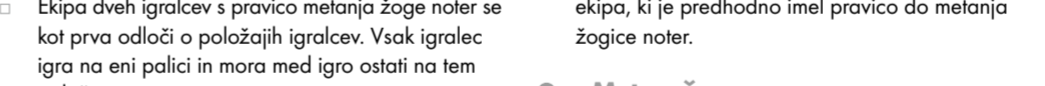
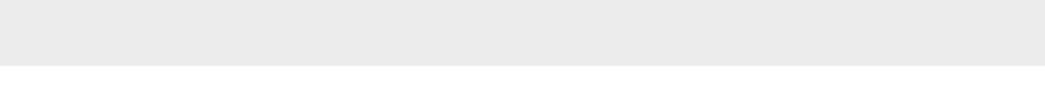
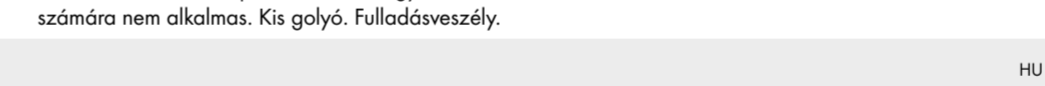
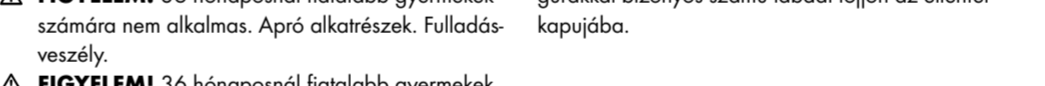
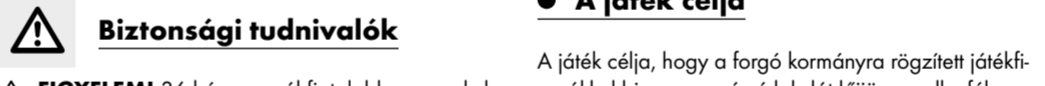
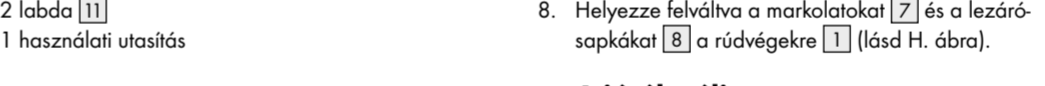
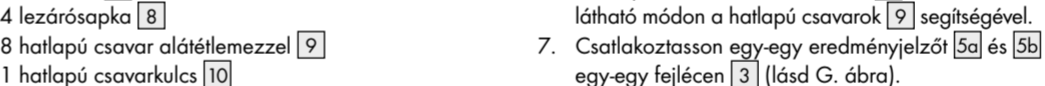
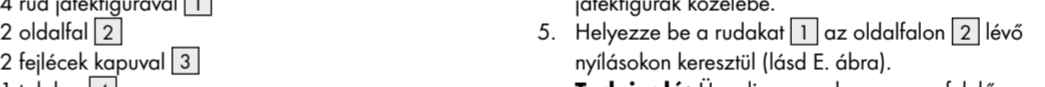
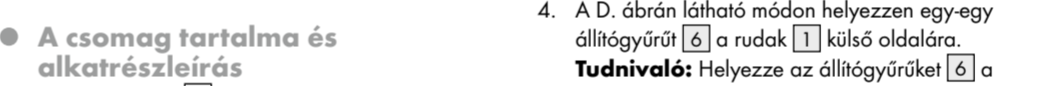
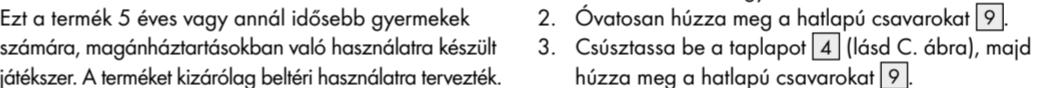
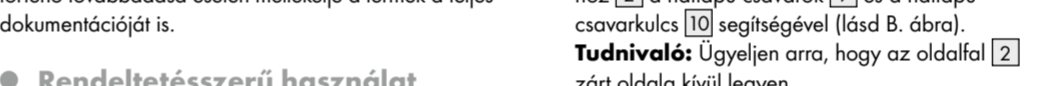
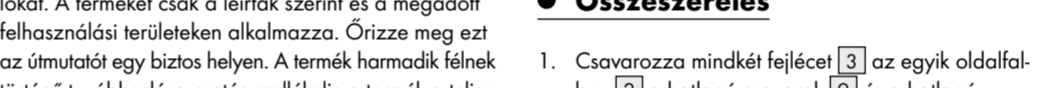
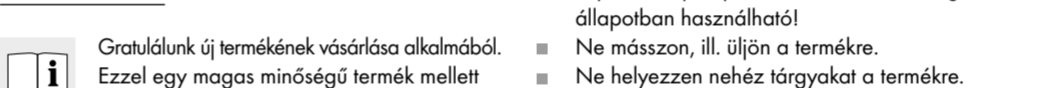
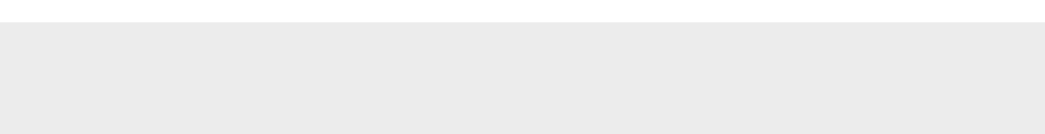
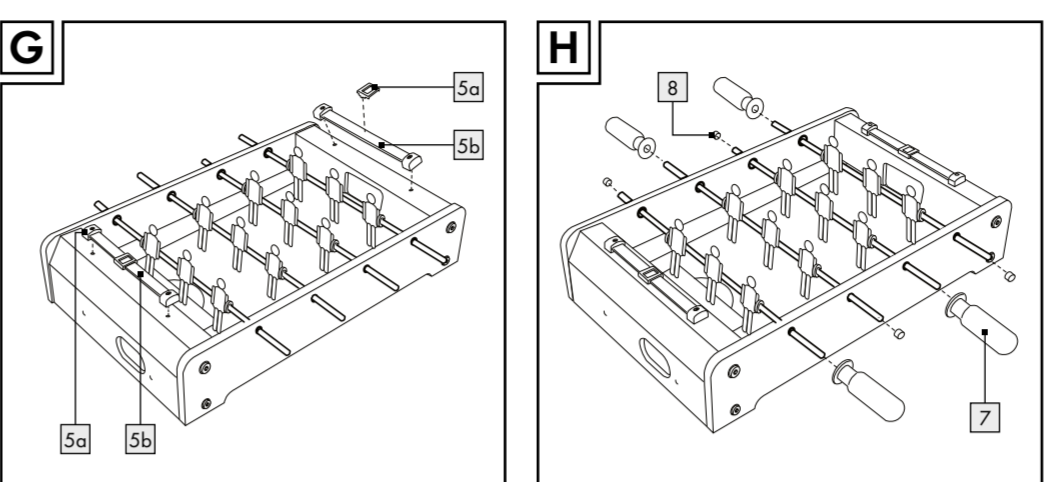
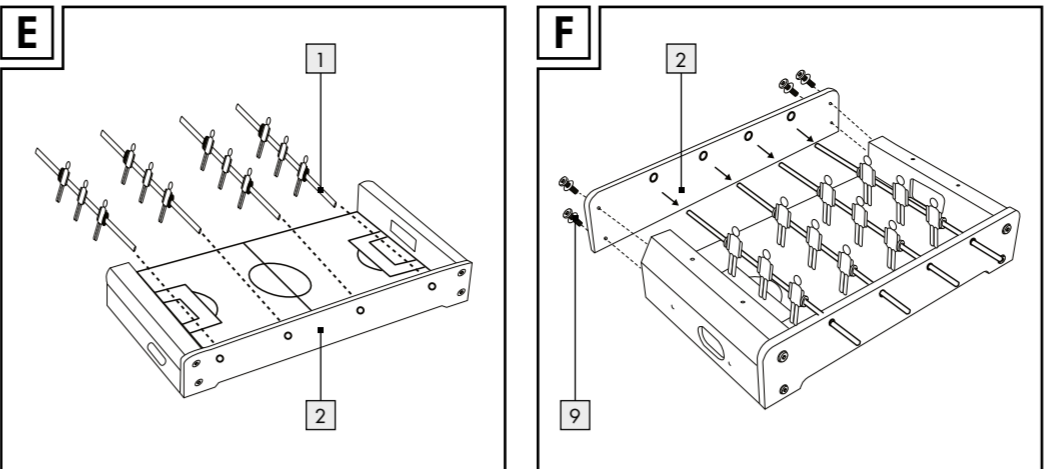
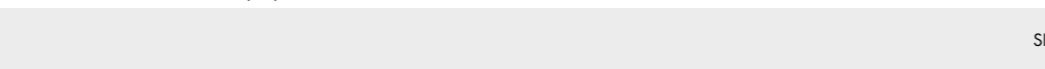
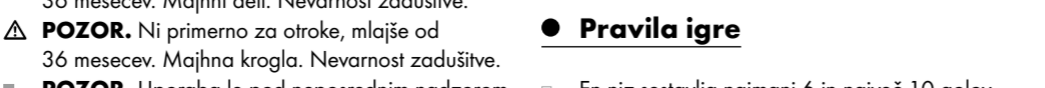
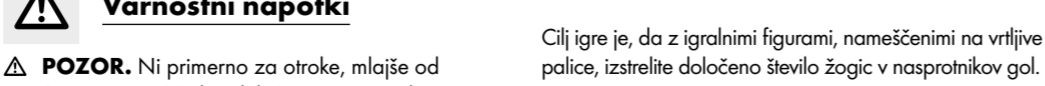
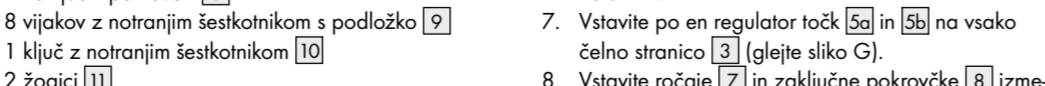
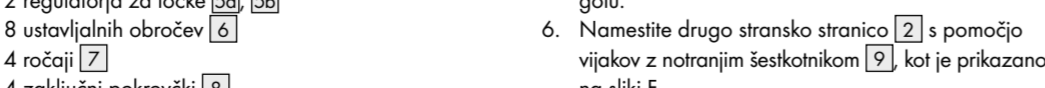
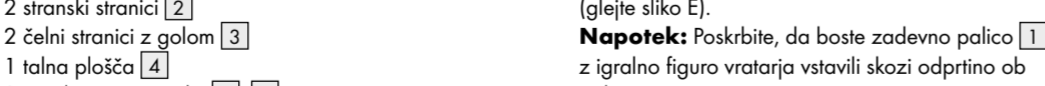
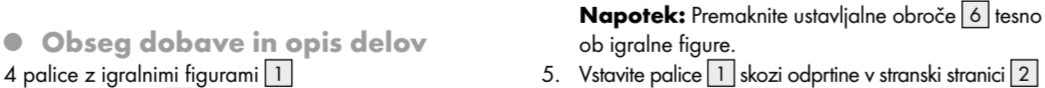
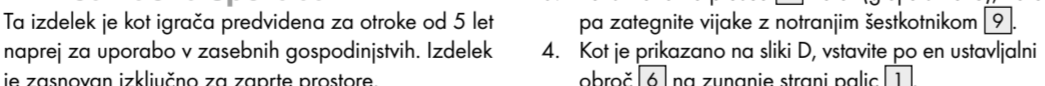
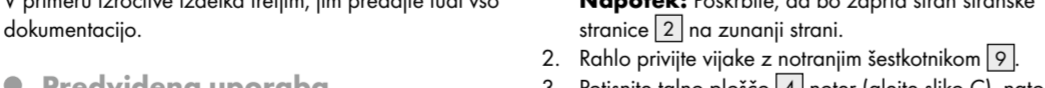
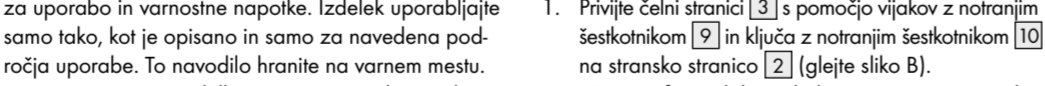
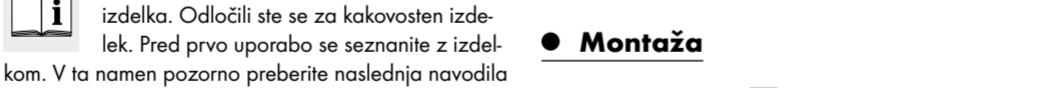
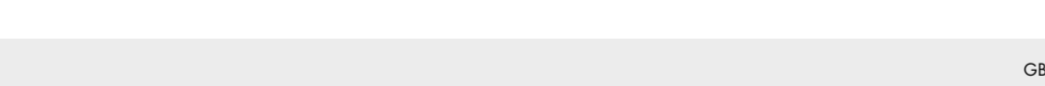
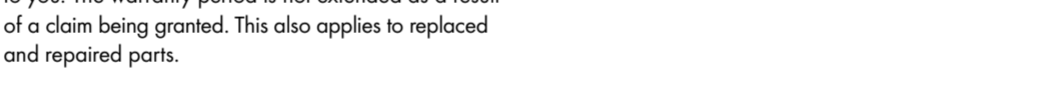
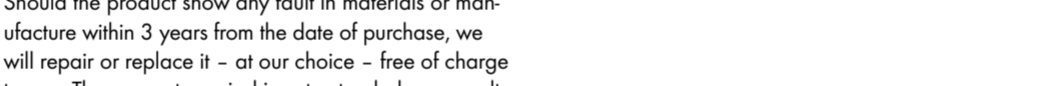
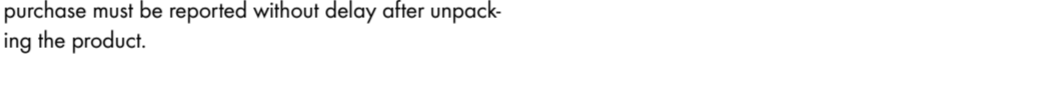
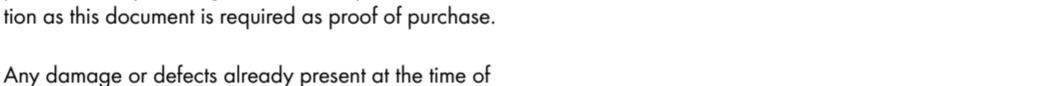
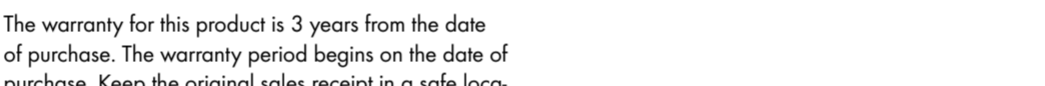
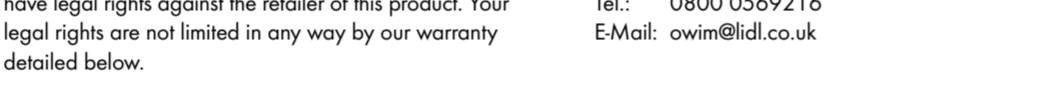
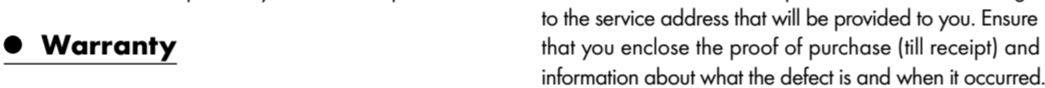
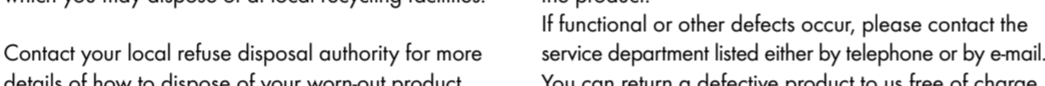
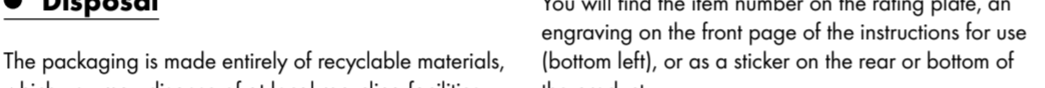
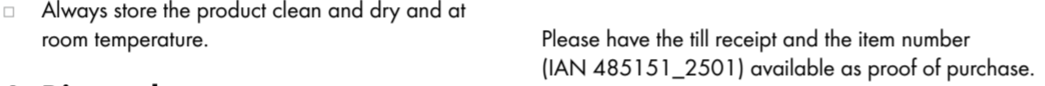
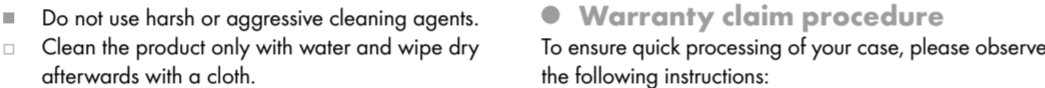
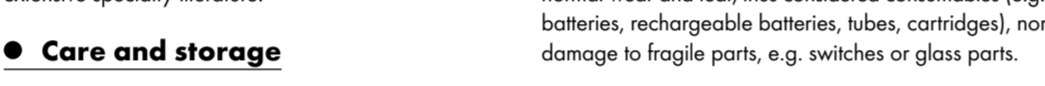
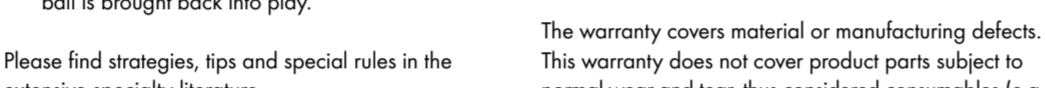
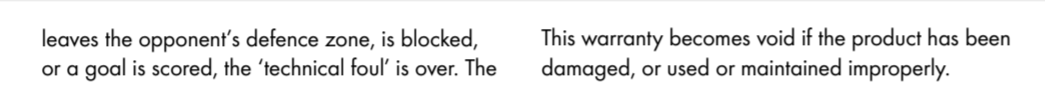
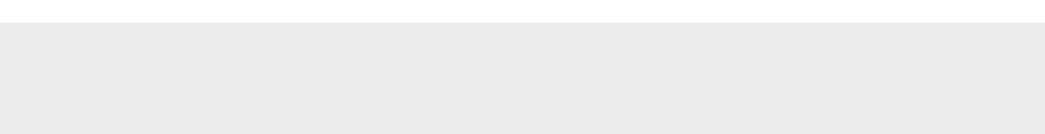
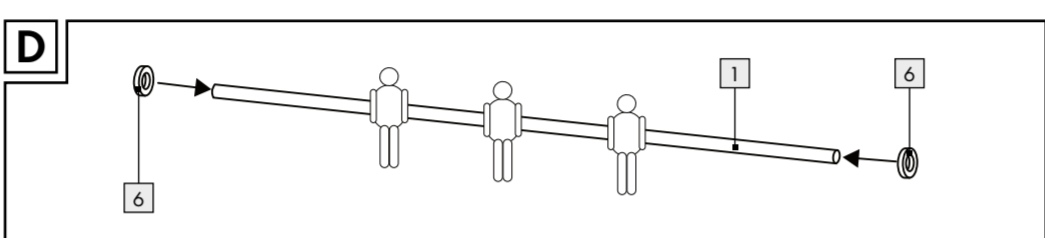
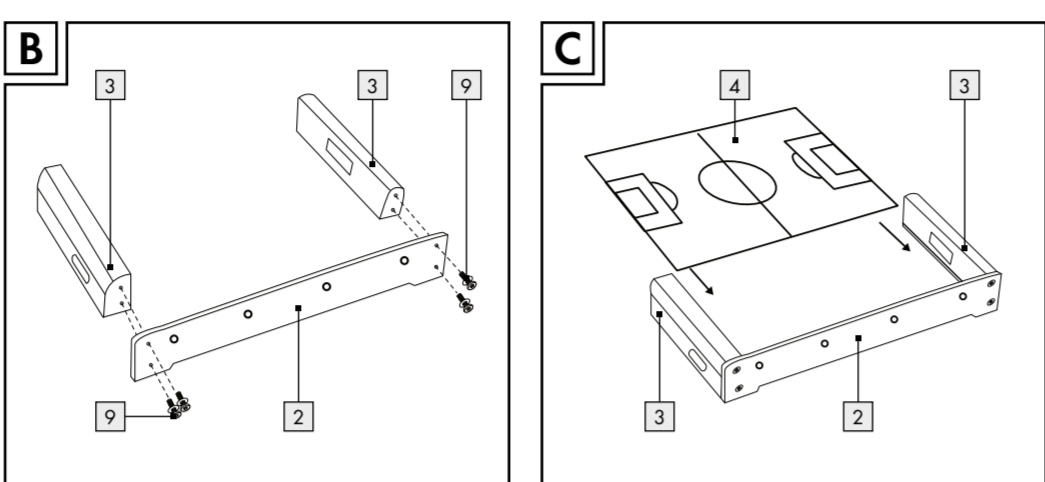
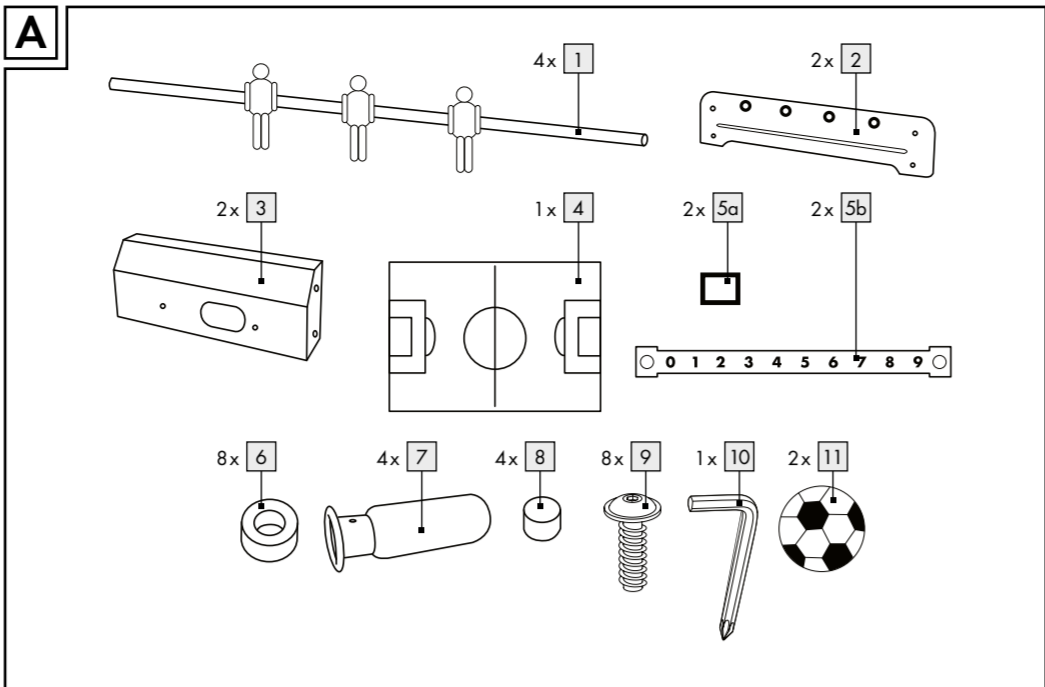

<b>List of pictograms used</b>	<span></span>
<span></span>	Safety information
<span></span>	Instructions for use

<b>Mini Football Table</b>	<span></span>
----------------------------	---------------

<b>● Introduction</b>	<span></span>
-----------------------	---------------

<b>●</b>	<span></span>
----------	---------------

<b>●</b>	<span></span>
----------	---------------

<b>●</b>	<span></span>
----------	---------------

<b>●</b>	<span></span>
----------	---------------

<b>●</b>	<span></span>
----------	---------------

<b>●</b>	<span></span>
----------	---------------

<b>●</b>	<span></span>
----------	---------------

<b>●</b>	<span></span>
----------	---------------

<b>●</b>	<span></span>
----------	---------------

<b>●</b>	<span></span>
----------	---------------

<b>●</b>	<span></span>
----------	---------------

<b>●</b>	<span></span>
----------	---------------

<b>●</b>	<span></span>
----------	---------------

<b>●</b>	<span></span>
----------	---------------

<b>●</b>	<span></span>
----------	---------------

<b>●</b>	<span></span>
----------	---------------

<b>●</b>	<span></span>
----------	---------------

<b>●</b>	<span></span>
----------	---------------

<b>●</b>	<span></span>
----------	---------------

<b>●</b>	<span></span>
----------	---------------

<b>●</b>	<span></span>
----------	---------------

<b>●</b>	<span></span>
----------	---------------

<b>●</b>	<span></span>
----------	---------------

<b>●</b>	<span></span>
----------	---------------

<b>●</b>	<span></span>
----------	---------------

<b>●</b>	<span></span>
----------	---------------

<b>●</b>	<span></span>
----------	---------------

<b>●</b>	<span></span>
----------	---------------

<b>●</b>	<span></span>
----------	---------------

<b>●</b>	<span></span>
----------	---------------

<b>●</b>	<span></span>
----------	---------------

<b>●</b>	<span></span>
----------	---------------

<b>●</b>	<span></span>
----------	---------------

<b>●</b>	<span></span>
----------	---------------

<b>●</b>	<span></span>
----------	---------------

<b>●</b>	<span></span>
----------	---------------

<b>●</b>	<span></span>
----------	---------------

<b>●</b>	<span></span>
----------	---------------

<b>●</b>	<span></span>
----------	---------------

<b>●</b>	<span></span>
----------	---------------

<b>●</b>	<span></span>
----------	---------------

<b>●</b>	<span></span>
----------	---------------

<b>●</b>	<span></span>
----------	---------------

<b>●</b>	<span></span>
----------	---------------

<b>●</b>	<span></span>
----------	---------------

<b>●</b>	<span></span>
----------	---------------

### ● Rules of the game

- One round consists of between 6 and 10 goals.
- The players/teams switch sides after each round. Both players/teams can choose to remain on their respective side.
- The 2-person team whose turn it is to throw in is the first to decide the position of the players. Each player operates one rod and must stay in their position during the game.
- When only 2 players are competing, each player operates all rods on their respective side.

### ● Game

- Flip a coin to determine which player or team will start.
- If you are throwing in, toss a tabletop football over the board onto the halfway line of the field. The ball is now 'in play'.
- Move the ball from row to row by manipulating the respective rod.
- Pass the ball until you can score a goal.
  - Note:** It counts as a goal if the ball passes the goal line, even if it ricochets back onto the field.

### ● Throwing in

- The ball is brought 'into play' at the halfway line when the match begins or after a goal. The player who is throwing in may try to influence the course of the ball.
- The players are prohibited from reaching into the playing area when the ball is 'in play'.
- The ball is 'in play' once it touches the playing field. Only then can the ball be played.
- The team who is throwing in cannot shoot a goal before the ball has touched a playing piece.
- The ball must not be thrown in before all players have confirmed that they are ready.

### ● Subsequent throw-ins

- The subsequent throw-ins are performed by the team/player against whom the last goal was scored.
- In a match with multiple rounds, the first throw is made by the team that lost the previous round.

<b>●</b>	<span></span>
----------	---------------

<b>●</b>	<span></span>
----------	---------------

<b>●</b>	<span></span>
----------	---------------

<b>●</b>	<span></span>
----------	---------------

<b>●</b>	<span></span>
----------	---------------

<b>●</b>	<span></span>
----------	---------------

<b>●</b>	<span></span>
----------	---------------

<b>●</b>	<span></span>
----------	---------------

<b>●</b>	<span></span>
----------	---------------

<b>●</b>	<span></span>
----------	---------------

<b>●</b>	<span></span>
----------	---------------

<b>●</b>	<span></span>
----------	---------------

<b>●</b>	<span></span>
----------	---------------

<b>●</b>	<span></span>
----------	---------------

<b>●</b>	<span></span>
----------	---------------

<b>●</b>	<span></span>
----------	---------------

<b>●</b>	<span></span>
----------	---------------

<b>●</b>	<span></span>
----------	---------------

<b>●</b>	<span></span>
----------	---------------

### ● Ball ‘in play’

- After the ball has been thrown in, it must remain 'in play'.

### ● ‘Out of bounds’

- The ball is 'out of bounds' if it touches an object outside of the playing area. It is then thrown in by the player/team that originally threw it in.

### ● ‘Dead ball’

- A 'dead ball' is a ball that is lying completely still and cannot be reached by any of the playing figures.
- If the ball is declared 'dead' between the goal and the nearest rod, it is placed in the nearest corner and rolled into the playing field.
- If the ball is declared 'dead' between the two middle rods, it is put back 'into play' at the halfway line by the team that originally threw it in.

### ● ‘Time out’

- Each team/player gets two 'time outs' per round.
- A 'time out' cannot last longer than 30 seconds.
- A 'time out' is only possible if the ball is not moving.
- Touching the ball is prohibited during the 'time out'. Violation of this rule results in loss of the ball to the opposing team/player.
- The players on a team can change positions during a 'time out'.

### ● Turning the rods

- The rods must not be rotated. Rotating the figure by more than 360° before or after ball contact is against the rules.
- If a ball that was moved by turning the rods enters the field, this does not count as a goal.
- If an own goal is scored by turning the rods, this counts as a goal for the opponent.

### ● Influencing the table

