



## STORAGE CABINET VERONA

 **Storage Cabinet**  
Assembly instruction

 **Kommode**  
Montageanleitung

 **Kumode**  
Montāžas instrukcija

---

GB	Assembly, safety and warranty instructions Assembly steps	Page	7-8 13-24
DE	Sicherheitshinweise, Garantie Zusammenbau	Seite	9-10 13-24
LV	Drošības instrukcijas, garantija Montāža	Lapa	11-12 13-24

---

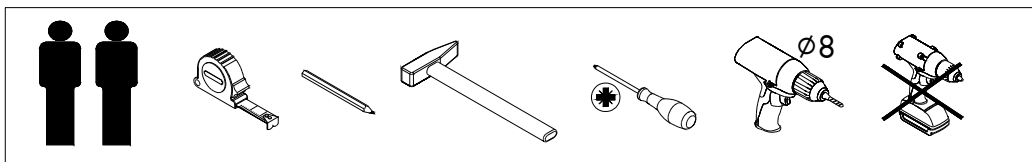
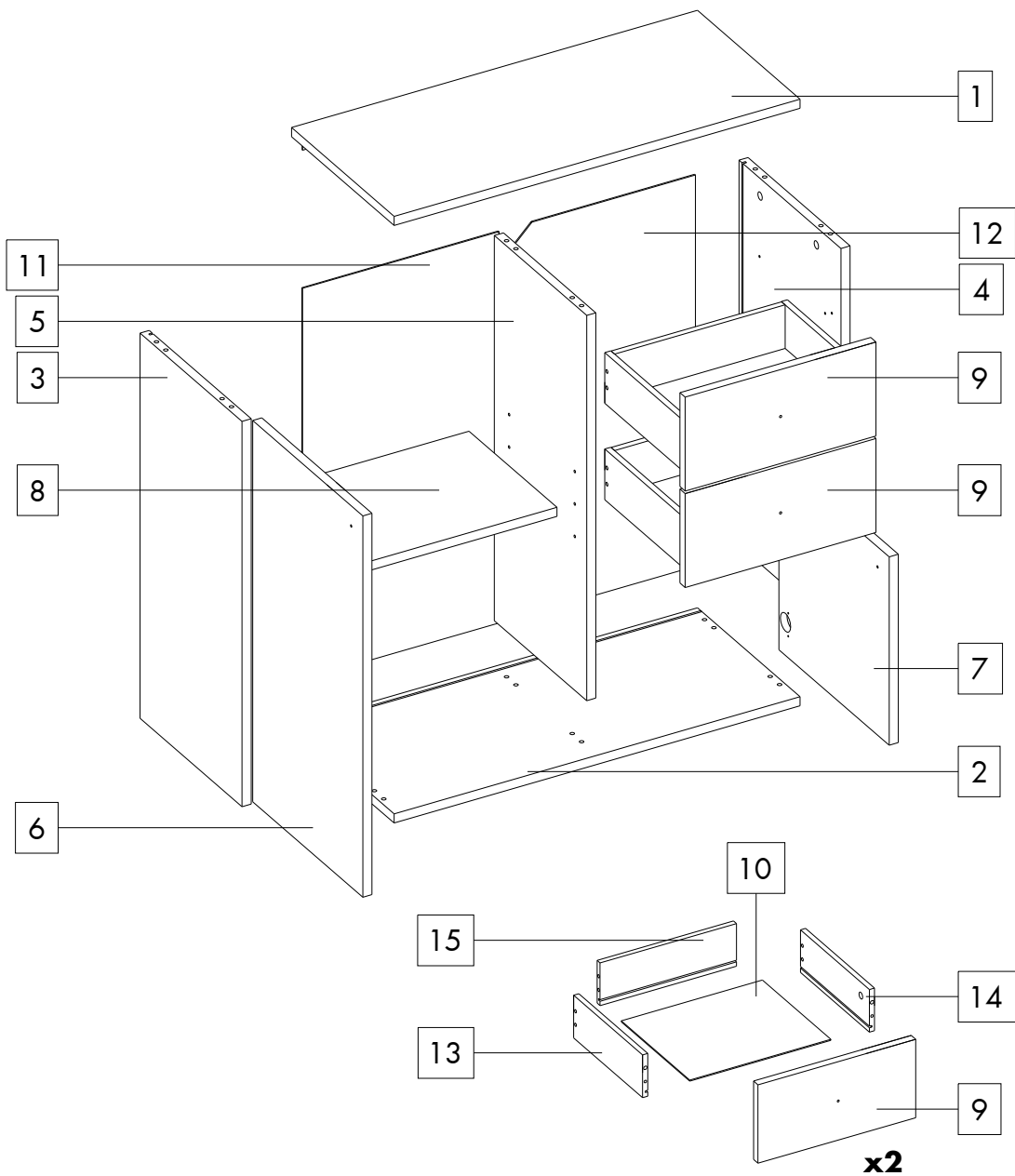

1

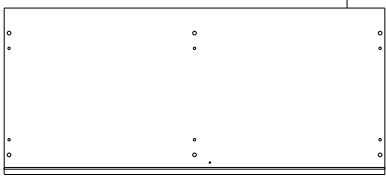

2

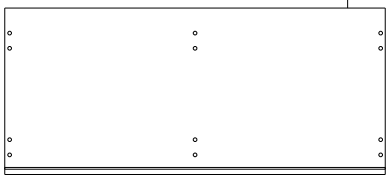

3

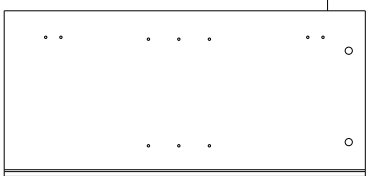

4

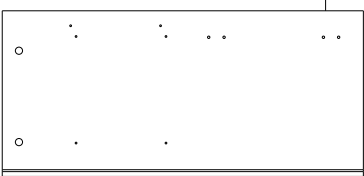

5

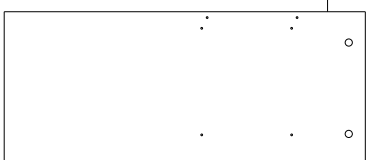

6

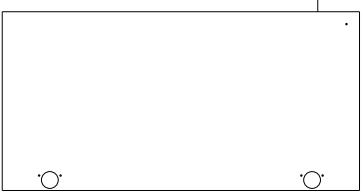

7

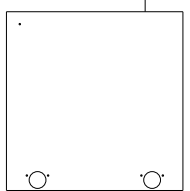

8

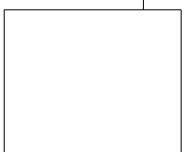

2x 9

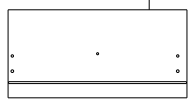

2x 10

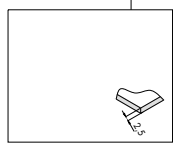

11



12

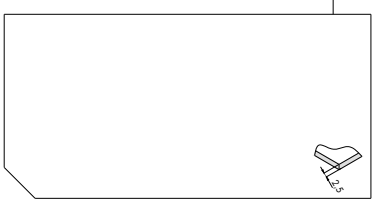

2x 13



2x 14



2x 15



12x 16



4x 17



6x 18

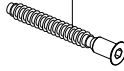

8x 19

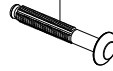

10x 20

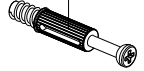

10x 21



4x 22



4x 23



2x 24

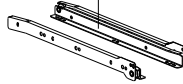

12x 25



4x 26



1x 27

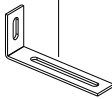

13x 28



3x 29

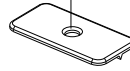

4x 30



4x 31

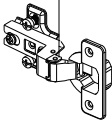

8x 32



1x 33



1x 34

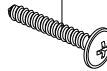

10x 35



4x 36



5x 37



1x 38



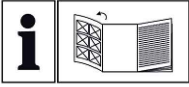

GB MT IE

Before reading, unfold the page containing the illustrations and familiarise yourself with all functions of the product.

---

DE AT CH

Klappen Sie vor dem Lesen die Seite mit den Abbildungen aus und machen Sie sich anschließend mit allen Funktionen des Produkts vertraut.

---

LV

Pirms lasīšanas, atlociet lapu ar ilustrācijām un pēc tam iepazīstieties ar visām produkta funkcijām.

---

## **Congratulations!**

You have chosen a high-quality product. The operating instructions are part of this product. They contain important information about safety, usage and disposal. Before using the product, please familiarise yourself with all operating and safety instructions. Use the product only as described and for the range of applications specified. Please also pass these operating instructions on to any future owner.

### **Intended use**

This product is intended solely for private use and not for commercial purposes. The warranty shall be deemed void in cases of misuse or improper handling, use of force and modifications / repairs which have not been carried out by one of our authorised Service centres.

### **Safety instructions**

Warning: Please follow directly the manufacturer assembly instruction. Deficient assembly causes safety risks. Please check if the surface is appropriate and choose appropriate fasteners. Assembling by qualified personnel is recommended.

Warning! Furniture consists small parts.

Warning! Children under 3 years shall not be unattended.

### **Wall fixing /ANTI-TOPPLE WARNING**

This product has to be permanently fixed to the wall with the bracket(s) included, to avoid fatal injury in case it topples over. In case of connective devices for the wall mounting, the supporting material must be checked for suitability.

### **Care instructions**

Please do only clean with a duster or a damp cloth.

Do not use any scouring agents!



## **Warranty**

Dear customer, this appliance comes with a 3-year warranty valid from the date of purchase. In the event that this product has any defects, you, the buyer, have certain statutory rights. Your statutory rights are not limited in any way by the warranty described below.

### **Warranty conditions**

The warranty period starts on the date of purchase. Please keep your receipt in a safe place. This will be required as proof of purchase. If any material or manufacturing fault occurs within 3 years of the product's date of purchase, we will either repair or replace the product for you or refund the purchase price (at our discretion). This warranty service requires that you present the defective appliance and the proof of purchase (receipt) within the 3-year warranty period, together with a brief written description of the fault and of when it occurred. If the defect is covered by the warranty, your product will either be repaired or replaced by us. The repair or replacement of a product does not signify the beginning of a new warranty period.

### **Warranty period and statutory claims for defects**

The warranty period is not prolonged by repairs effected under the warranty. This also applies to replaced and repaired components. Any damage and defects present at the time of purchase must be reported immediately after unpacking. Repairs carried out after expiry of the warranty period shall be subject to a fee.

### **Scope of the warranty**

This appliance has been manufactured in accordance with strict quality guidelines and inspected meticulously prior to delivery. The warranty covers material faults or production faults. The warranty does not extend to product parts subject to normal wear and tear or to fragile parts which could be considered as consumable parts such as switches or parts made of glass. The warranty does not apply if the product has been damaged, improperly used or improperly maintained. The directions in the operating instructions for the product regarding proper use of the product are to be strictly followed. Uses and actions that are discouraged in the operating instructions or which are warned against must be avoided

### **Disposal**

Please dispose packaging and product after use in an environmentally sound manner.

## Herzlichen Glückwunsch!

Sie haben sich damit für ein hochwertiges Produkt entschieden. Die Bedienungsanleitung ist Teil dieses Produkts. Sie enthält wichtige Hinweise für Sicherheit, Gebrauch und Entsorgung. Machen Sie sich vor der Benutzung des Produkts mit allen Bedien- und Sicherheitshinweisen vertraut. Benutzen Sie das Produkt nur wie beschrieben und für die angegebenen Einsatzbereiche. Händigen Sie alle Unterlagen bei Weitergabe des Produkts an Dritte mit aus.

## Bestimmungsgemäße Verwendung

Das Produkt ist lediglich für den privaten und nicht für den gewerblichen Gebrauch bestimmt. Bei missbräuchlicher und unsachgemäßer Behandlung, Gewaltanwendung und bei Eingriffen, die nicht von unserer autorisierten Service-Niederlassung vorgenommen wurden, erlischt die Garantie.

## Sicherheitshinweis

Achtung: Die Montage muss exakt nach den Anweisungen des Herstellers erfolgen - anderenfalls kann eine fehlerhafte Montage zu einem Sicherheitsrisiko führen. Bei mangelhafter Montage besteht Gefahr für die Sicherheit. Prüfen Sie bitte den Untergrund auf Eignung und wählen Sie geeignete Befestigungsmittel. Aufbau durch fachkundiges Personal empfohlen!

Achtung! Möbel enthält verschluckbare Kleinteile.

Achtung! Kinder < 3 Jahre nicht ohne Beaufsichtigung lassen.

## Wandmontage

WARNHINWEIS: Um ein Umkippen zu verhindern, ist dieses Produkt mit dem mitgelieferten Schrankaufhänger zu verwenden. Bei Verbindungsmittel für die Wandbefestigung ist das Trägermaterial auf Eignung zu prüfen.

## Pflegehinweis

Bitte nur mit einem Staubtuch oder einem feuchten Lappen reinigen. Keine scheuernden Putzmittel verwenden!

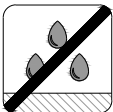

## **Garantiezeit und gesetzliche Mängelansprüche**

Die Garantiezeit wird durch die Gewährleistung nicht verlängert. Dies gilt auch für ersetzte und reparierte Teile. Eventuell schon beim Kauf vorhandene Schäden und Mängel müssen sofort nach dem Auspacken gemeldet werden. Nach Ablauf der Garantiezeit anfallende Reparaturen sind kostenpflichtig.

## **Garantieumfang**

Das Produkt wurde nach strengen Qualitätsrichtlinien sorgfältig produziert und vor Anlieferung gewissenhaft geprüft. Die Garantieleistung gilt für Material- oder Fabrikationsfehler. Diese Garantie erstreckt sich nicht auf Produktteile, die normaler Abnutzung ausgesetzt sind und daher als Verschleißteile angesehen werden können oder für Beschädigungen an zerbrechlichen Teilen, z. B. Schalter, oder Teile, die aus Glas gefertigt sind. Diese Garantie verfällt, wenn das Produkt beschädigt, nicht sachgemäß benutzt oder gewartet wurde. Für eine sachgemäße Benutzung des Produkts sind alle in der Bedienungsanleitung aufgeführten Anweisungen genau einzuhalten. Verwendungszwecke und Handlungen, von denen in der Bedienungsanleitung abgeraten oder vor denen gewarnt wird, sind unbedingt zu vermeiden.

## **Garantie**

Sehr geehrte Kundin,  
sehr geehrter Kunde, Sie erhalten auf dieses Produkt 3 Jahre Garantie ab Kaufdatum. Im Falle von Mängeln dieses Produkts stehen Ihnen gegen den Verkäufer des Produkts gesetzliche Rechte zu. Diese gesetzlichen Rechte werden durch unsere im Folgenden dargestellte Garantie nicht eingeschränkt.

## **Garantiebedingungen**

Die Garantiefrist beginnt mit dem Kaufdatum. Bitte bewahren Sie den Original Kassenbon gut auf. Dieser wird als Nachweis für den Kauf benötigt. Tritt innerhalb von drei Jahren ab dem Kaufdatum dieses Produkts ein Material- oder Fabrikationsfehler auf, wird das Produkt von uns - nach unserer Wahl - für Sie kostenlos repariert, ersetzt, oder der Kaufpreis erstattet. Diese Garantieleistung setzt voraus, dass innerhalb der Drei-Jahres-Frist das defekte Produkt und der Kaufbeleg (Kassenbon) vorgelegt und schriftlich kurz beschrieben wird, worin der Mangel besteht und wann er aufgetreten ist. Wenn der Defekt von unserer Garantie gedeckt ist, erhalten Sie das reparierte oder ein neues Produkt zurück. Mit Reparatur oder Austausch des Produkts beginnt kein neuer Garantiezeitraum.

## **Entsorgung**

Bitte entsorgen Sie Verpackung und Produkt nach der Verwendung umweltgerecht.

## Apsveicam!

Jūs esat izvēlēties augstas kvalitātes produktu. Lietošanas instrukcija ir šī produkta sastāvdaļa. Tajā ir svarīga informācija par drošību, lietošanu un iznīcināšanu. Pirms produkta lietošanas iepazīstieties ar visiem lietošanas un drošības norādījumiem. Izmantojiet produktu tikai tā, kā aprakstīts, un norādītajām lietošanas jomām. Nododiet visus dokumentus līdzī ja produkts tiek nodots trešajām personām.

## Paredzētais lietojums

Produkts ir paredzēts tikai privātām vajadzībām, nevis komerciālai lietošanai. Garantijas termiņš beidzas nepareizas un neatbilstošas apstrādes, nepareizas izmantošanas un iejaukšanās gadījumā, ko nav veikusi mūsu pilnvarotā servisa filiāle.

## Drošības norādījumi

Uzmanību: Montāža jāveic precīzi saskaņā ar ražotāja norādījumiem - pretējā gadījumā nepareiza montāža var radīt drošības riskus. Nepareiza montāža rada risku drošībai. Lūdzu, pārbaudiet pamatnes piemērotību un izvēlieties piemērotus stiprinājumus. Montāžu iesaka kompetents personāls!

Bīstami! Mēbeles satur mazas daļas, kuras var norīt.

Bīstami! Neatstājiet bērnus, kas jaunāki par 3 gadiem, bez uzraudzības.

## Montāža pie sienas

BRĪDINĀJUMS: Lai pasargātu to no apgāšanās, šis produkts jālieto kopā ar komplektā esošo skapīša pakaramo. Attiecībā uz stiprinājumiem, kas paredzēti piestiprināšanai pie sienas, jāpārbauda nesēja materiāla piemērotība.

## Apkopes instrukcija

Lūdzu, tīriet tikai ar putekļu sūcēju vai mitru drānu. Nelietojiet abrazīvus tīrīšanas līdzekļus!



## **Garantijas periods un likumā noteiktās prasības par defektiem.**

Garantija nepagarina garantijas periodu. Tas attiecas arī uz nomainītām un salabotām detaļām. Par visiem bojājumiem vai defektiem, kas jau ir iegādes brīdī, jāziņo tūlīt pēc izpakošanas. Remonts, kas veikts pēc garantijas perioda beigām, ir jāmaksā.

## **Garantijas darbības joma**

Produkts tika rūpīgi ražots saskaņā ar stingrām kvalitātes vadlīnijām un pirms piegādes atbilstoši pārbaudīts. Garantija attiecas uz materiālu vai ražošanas defektiem. Šī garantija neattiecas uz produkta daļām, kuras normāli nolietojas, un tāpēc tās var uzskatīt par lietojamām vai par trauslu daļu bojājumiem, piemēram, slēdži vai daļas, kas izgatavotas no stikla. Šī garantija nav spēkā, ja produkts ir bojāts, nepareizi izmantots vai tiek apkopts. Pareizai produkta lietošanai ir stingri jāievēro visi lietošanas instrukcijā sniegtie norādījumi. Par katru cenu ir jāizvairās no lietošanas un darbībām, kuras ekspluatācijas instrukcijā nav ieteiktas vai par kurām nav brīdināts.

## **Garantija**

Cienījamā kliente,

cienījamais klient, jūs saņemat 3 gadu garantiju šim produktam sākot no pirkuma datuma. Šī produkta defektu gadījumā jums ir likumīgas tiesības pret produkta pārdevēju. Šīs likumīgās tiesības neierobežo mūsu garantija, kā norādīts zemāk.

## **Garantijas nosacījumi**

Garantijas periods sākas pirkuma dienā. Lūdzu, glabājiet kvīti oriģinālu drošā vietā. Tas ir nepieciešams kā pirkuma apliecinājums. Stājas spēkā trīs gadu laikā no šī produkta, materiāla vai produkta iegādes dienas vai ja ir ražošanas defekti, mēs - pēc mūsu izvēles - jums bez maksas salabosim, nomainīsim vai pirkuma cena tiks atmaksāta. Šī garantija nosaka, ka produkts ar trūkumiem un pirkuma čeks (kvīts) tiek uzrādīti trīs gadu laikā un rakstiski īsi aprakstīti, no kā sastāv defekts un kad tas radies. Ja defektu sedz mūsu garantija, jūs saņemsit labotu vai jaunu produktu atpakaļ. Neviens jauns garantijas periods nesākas ar produkta remontu vai nomaiņu.

## **Iznīcināšana**

Lūdzu, pēc lietošanas iznīciniet iepakojumu un produktu videi draudzīgā veidā.

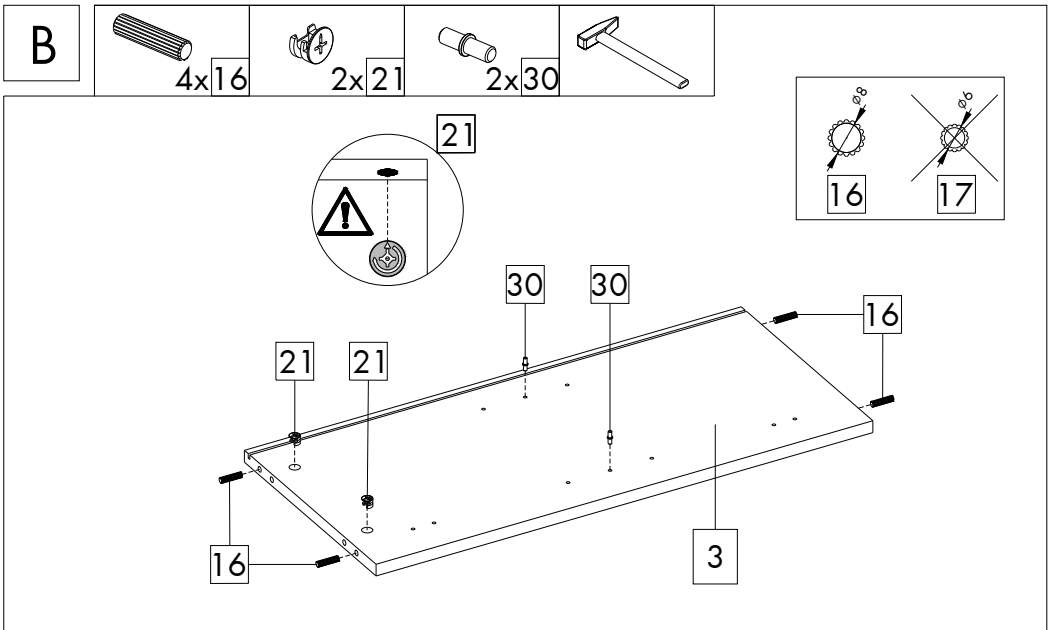
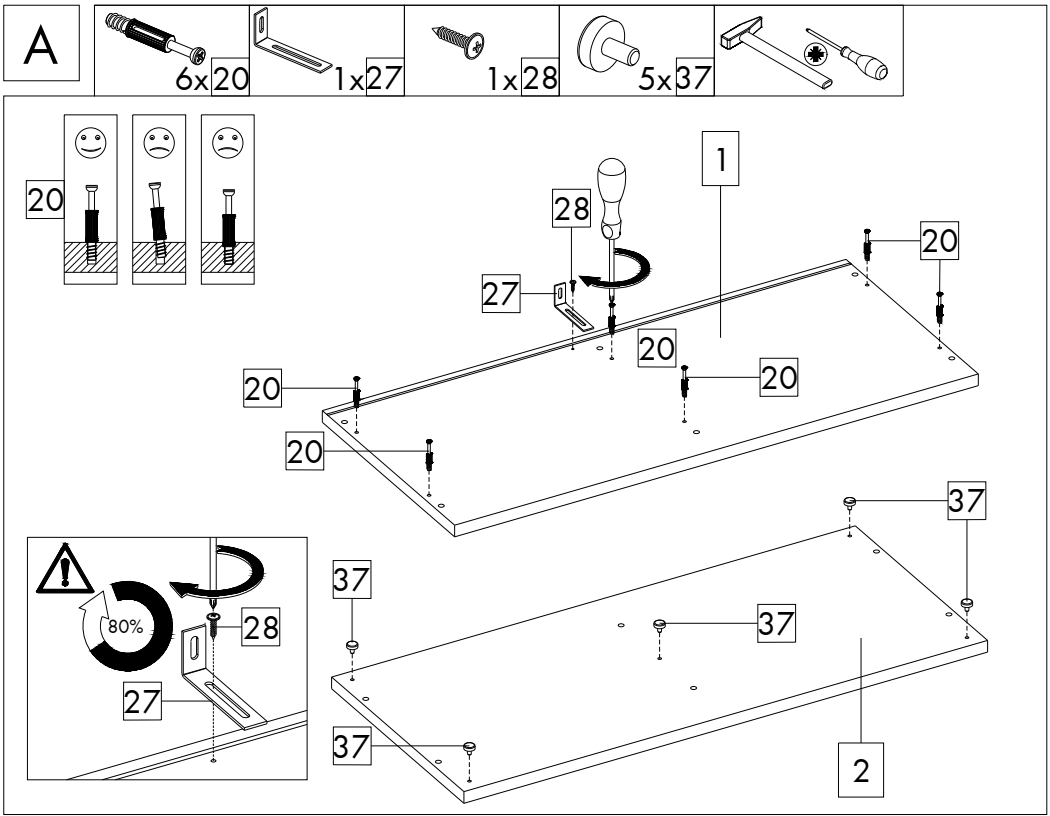

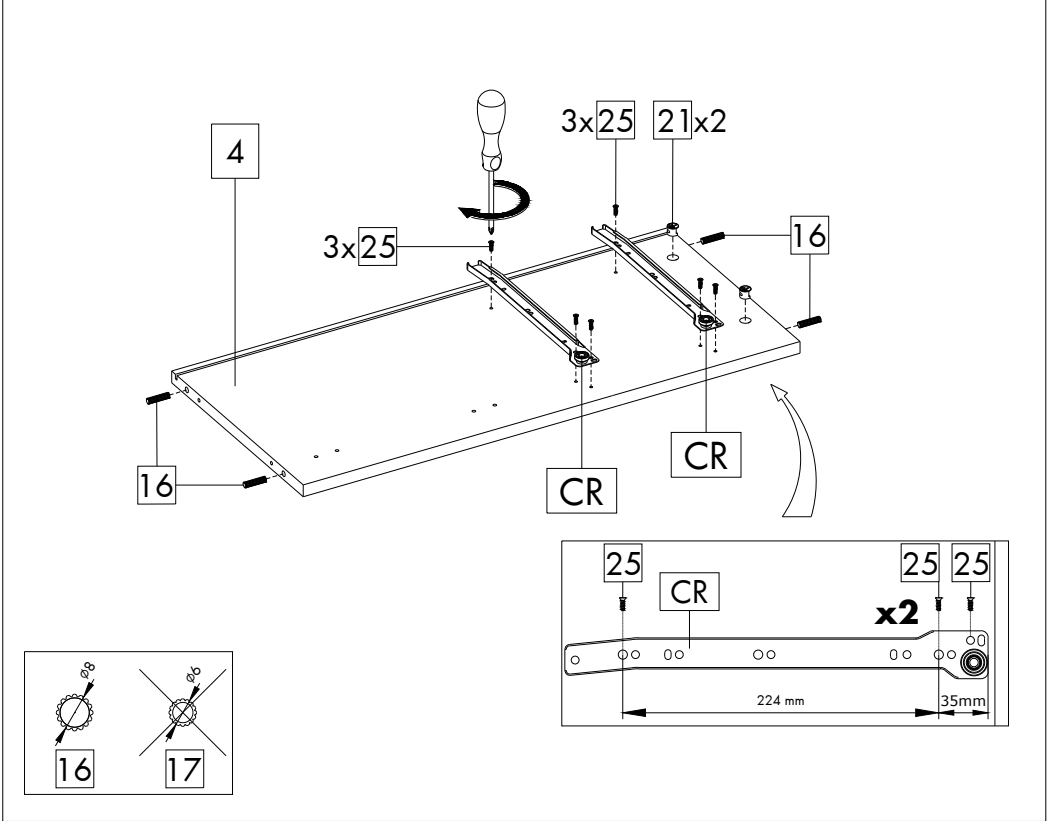
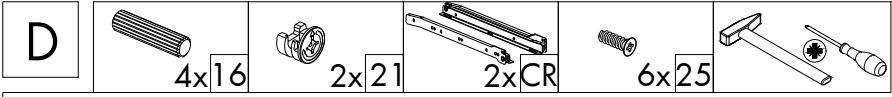
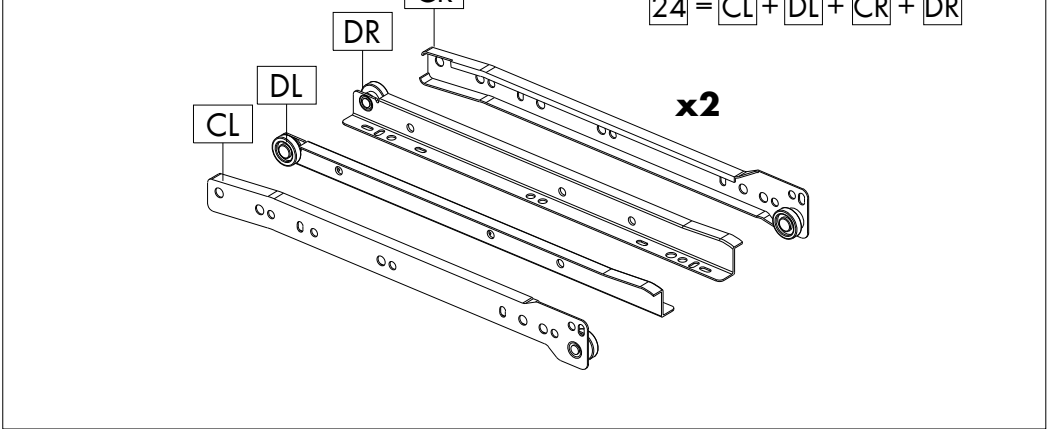
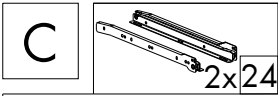

E



4x16



2x21

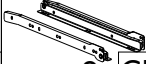

2xCL



6x25



2x30

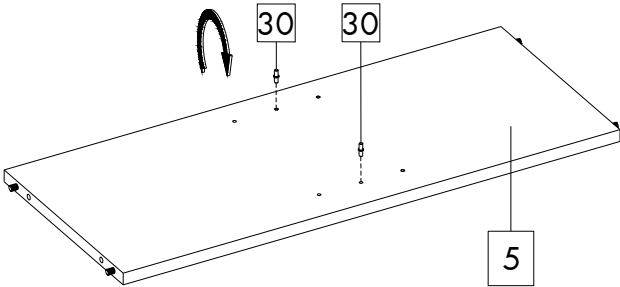
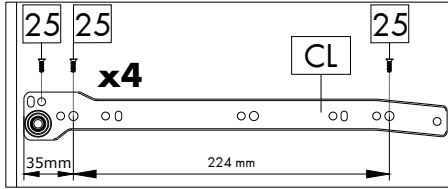
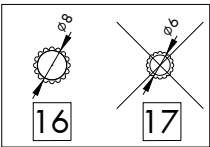
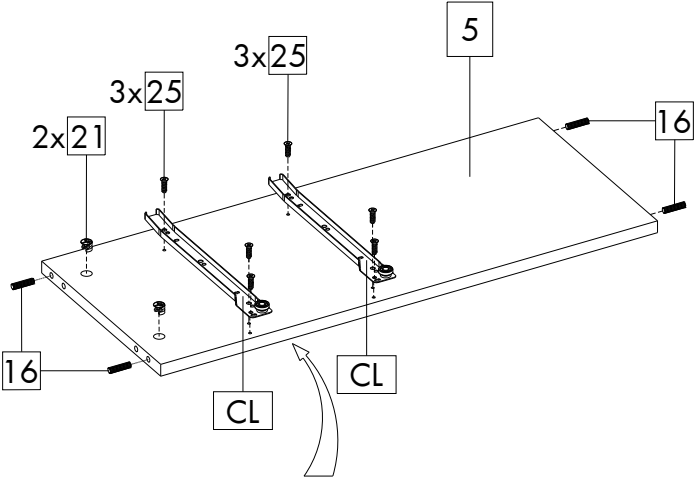
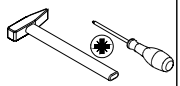

**F**

6x18



1x38

4

5

3

18

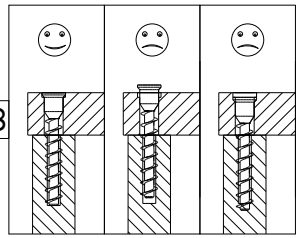

2

38

18x2

18x2

18x2

**G**

12

11

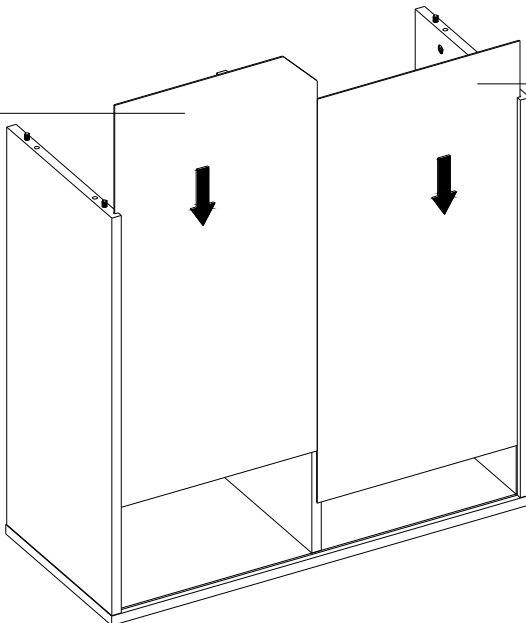

H



4x23

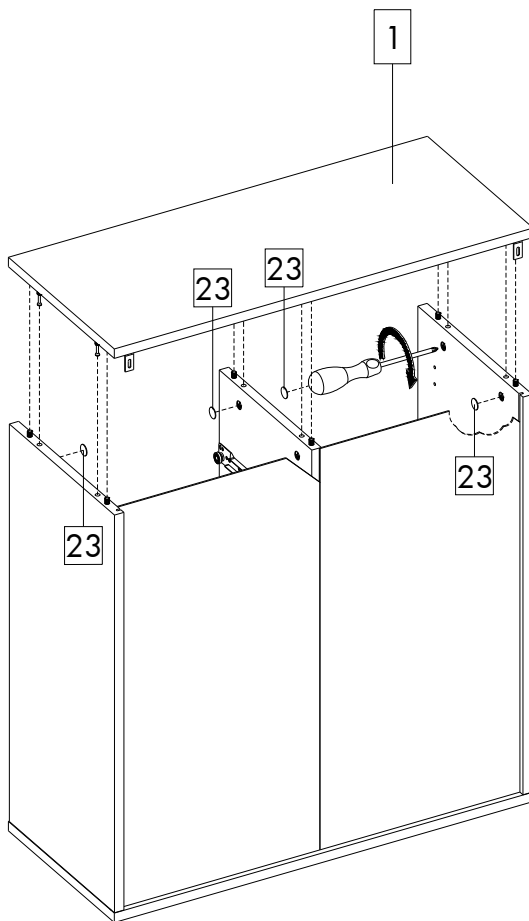
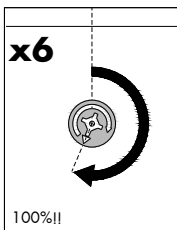
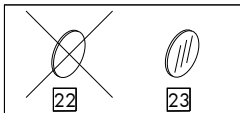

I

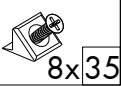

$XX=YY=90^\circ$

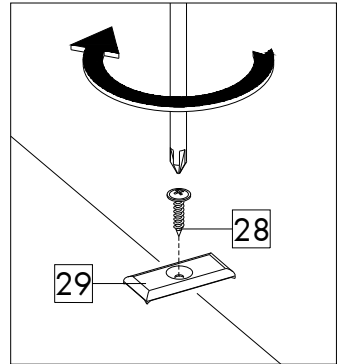
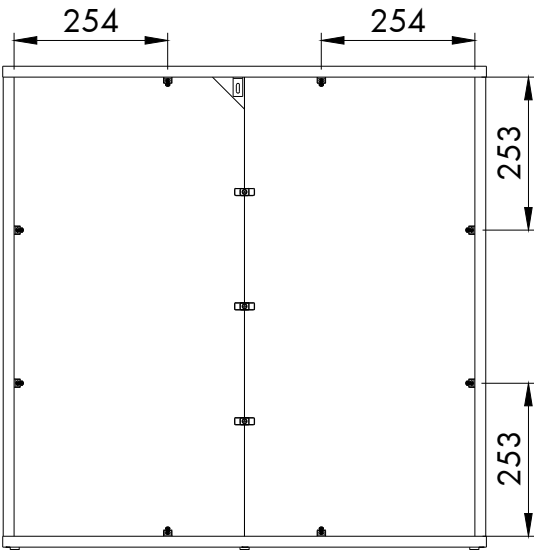
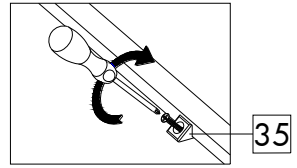
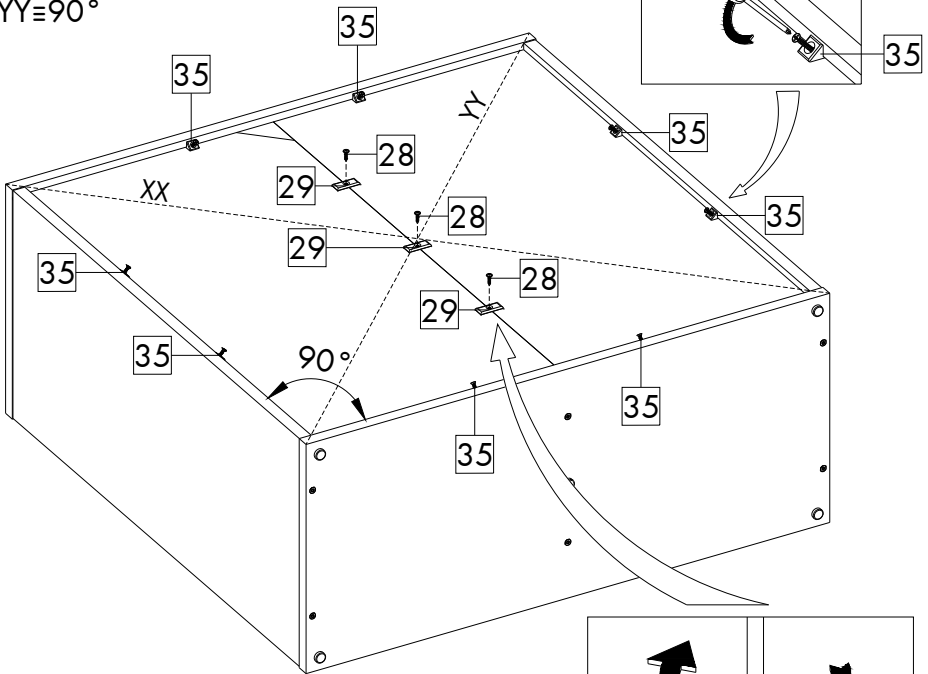

J



1x28



1x33



1x34



ø8

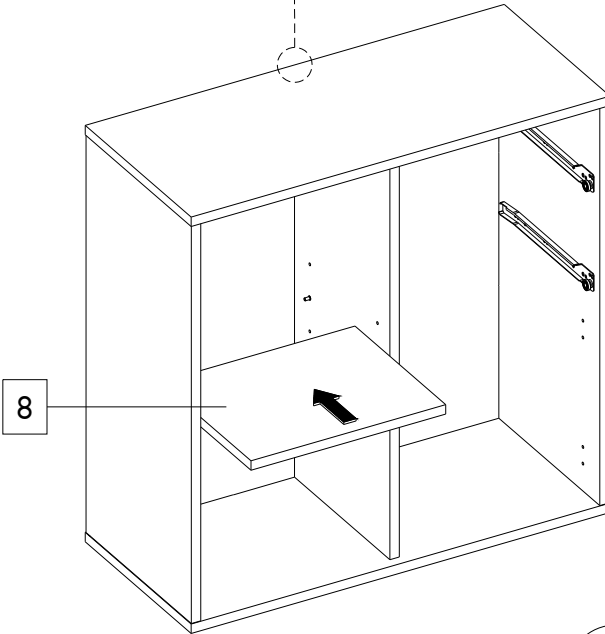
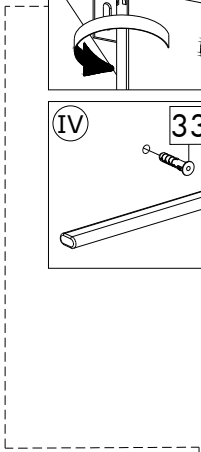
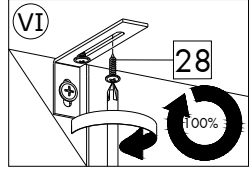
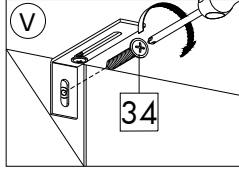
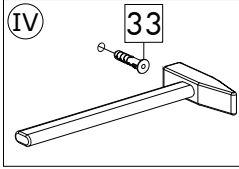
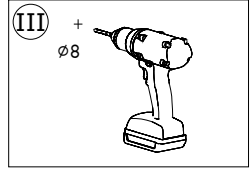
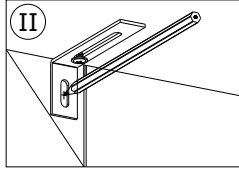
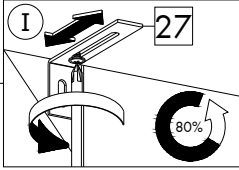
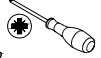
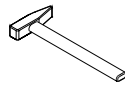

8

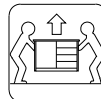

K

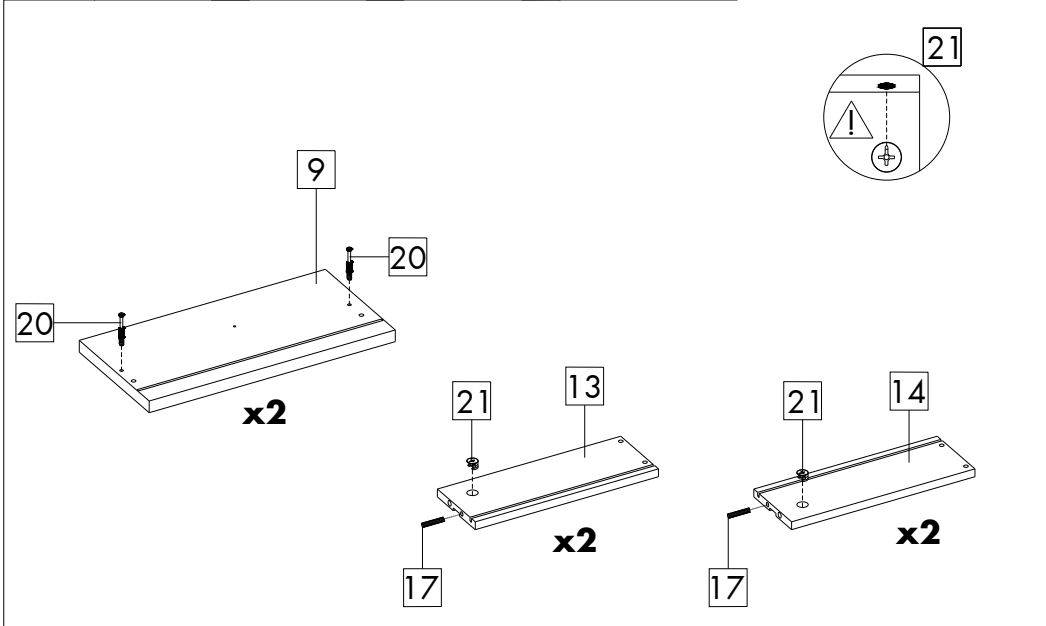
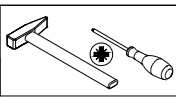
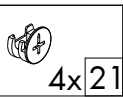
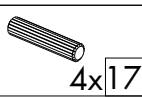
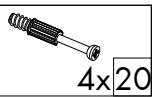

L

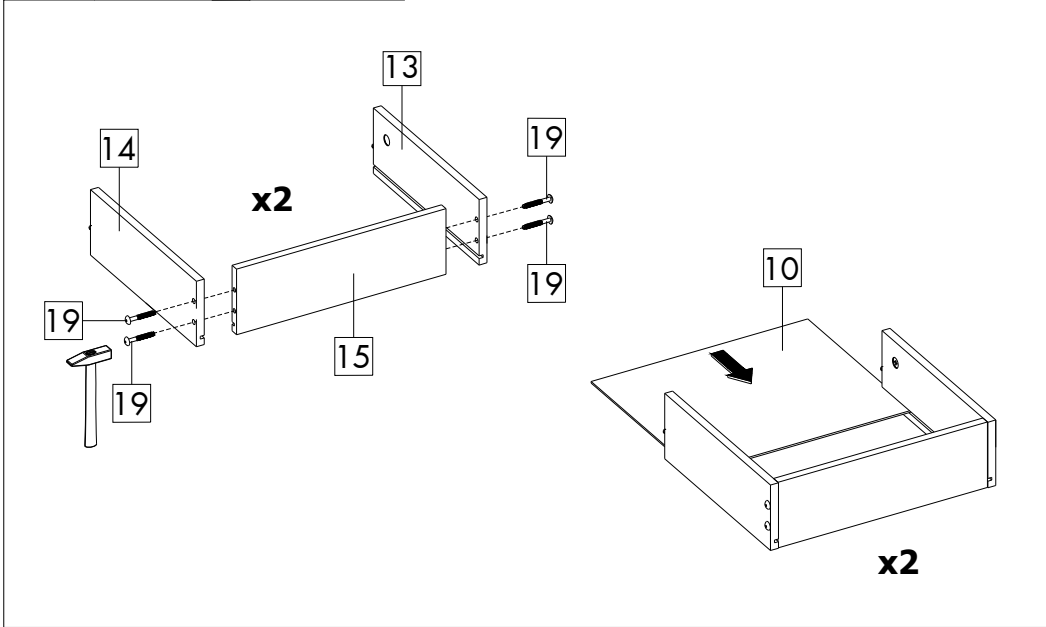
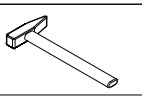
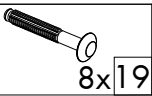

M

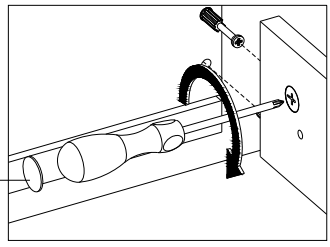
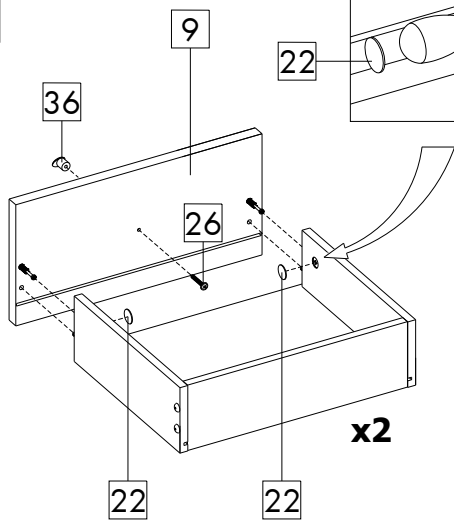
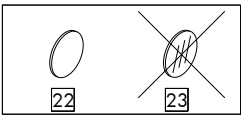
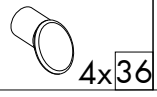
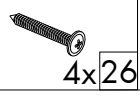
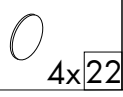

N

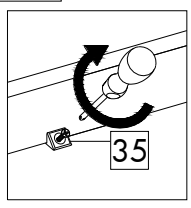
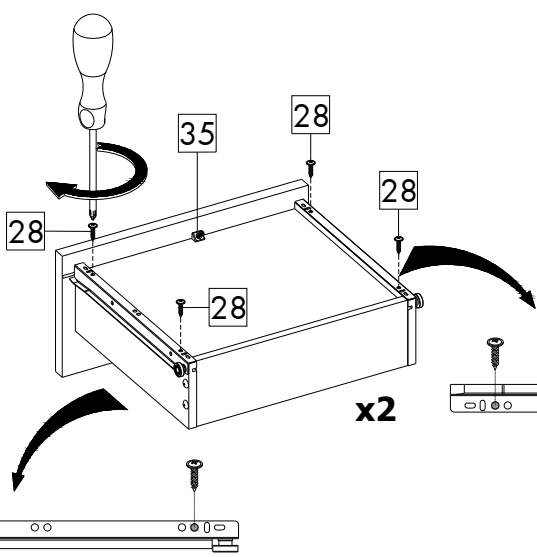
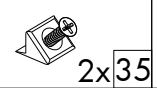
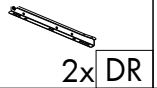
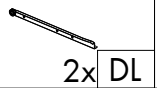
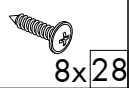

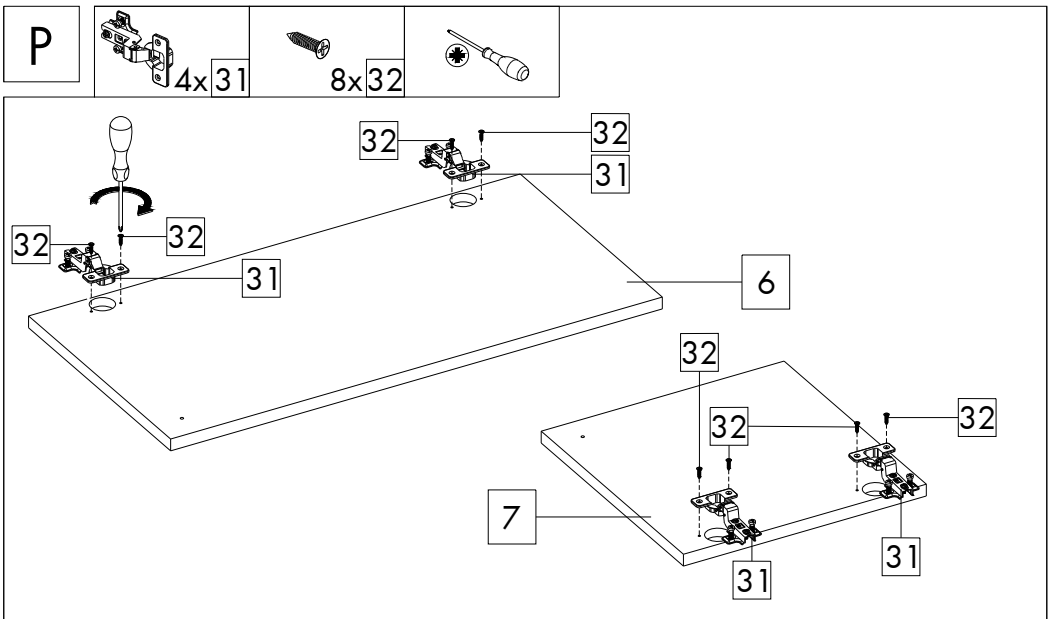
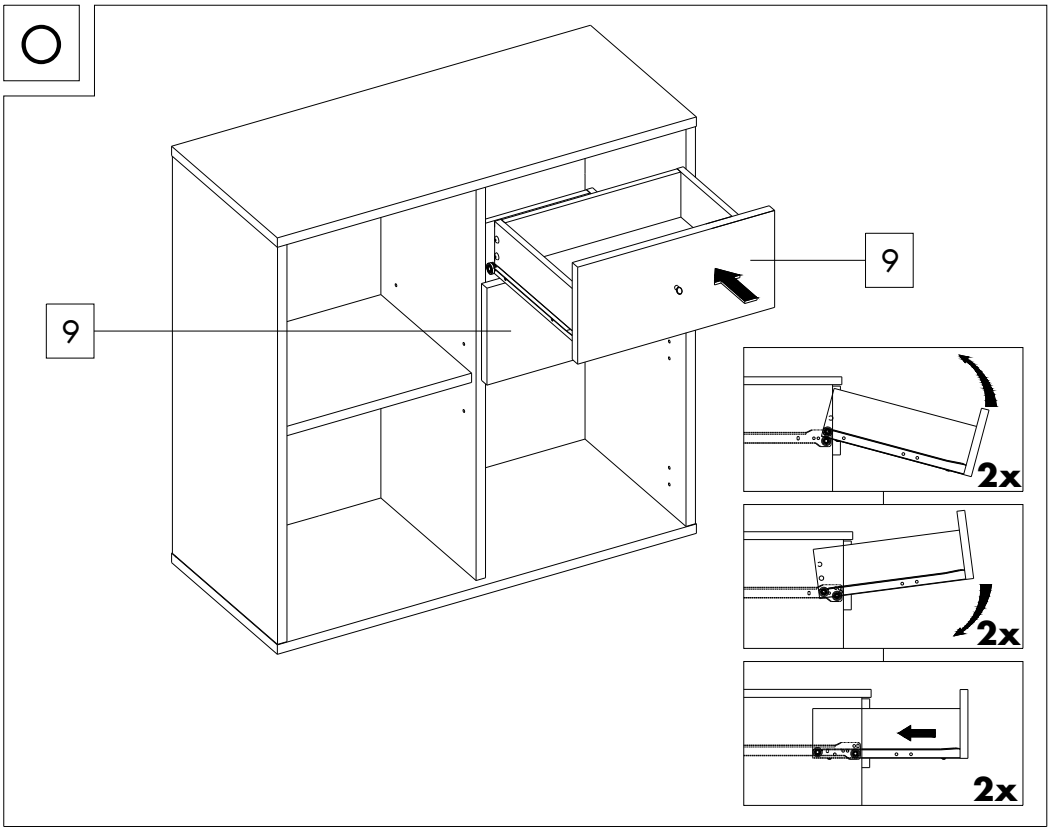

Q

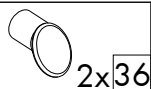

2x36



2x26

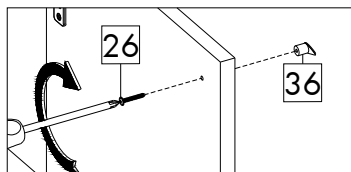
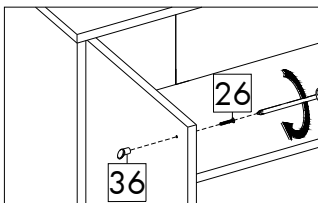
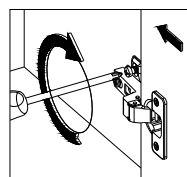
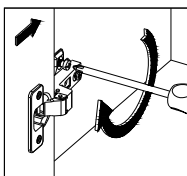
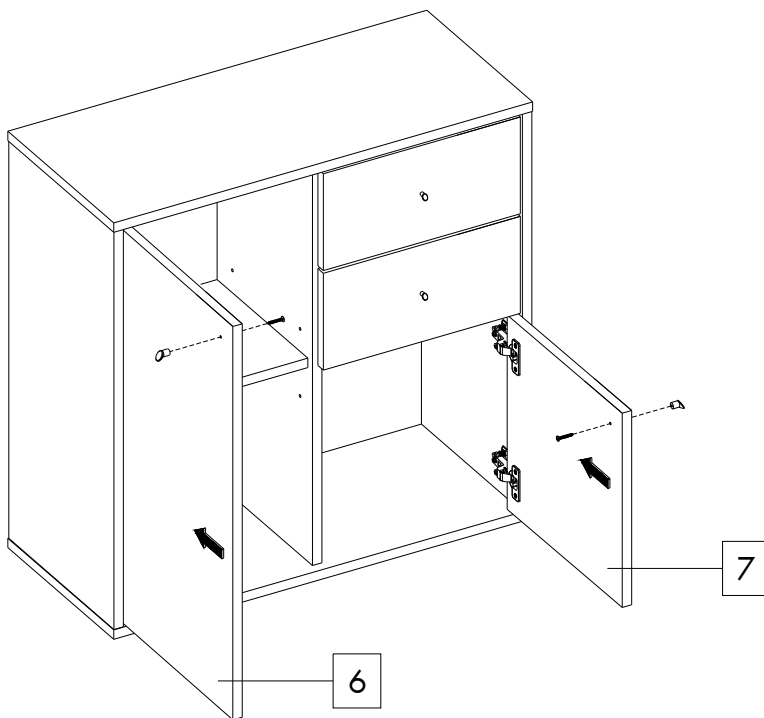

R

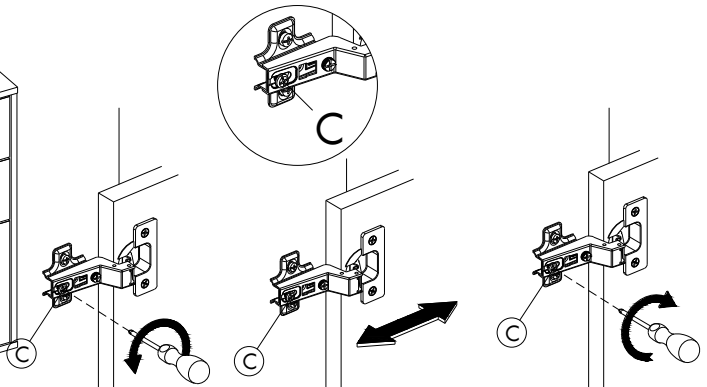
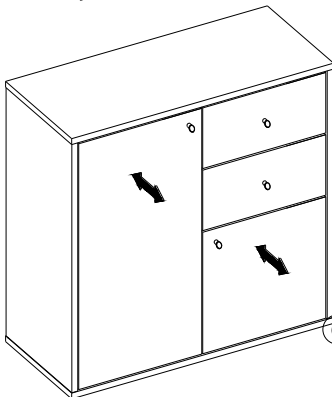
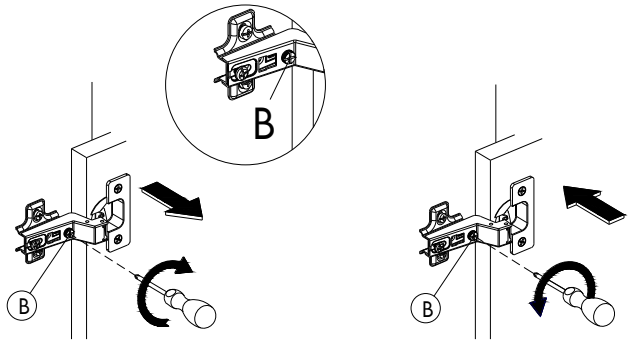
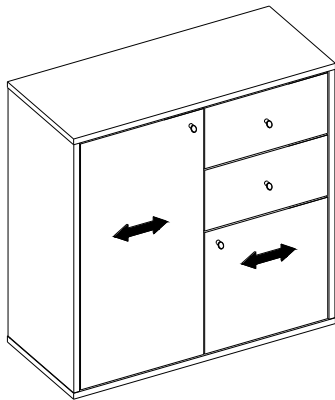
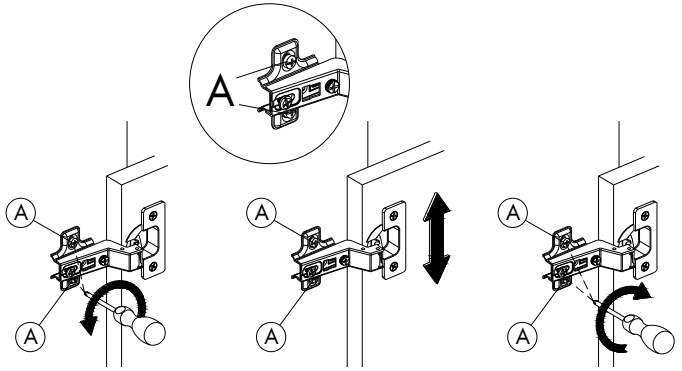
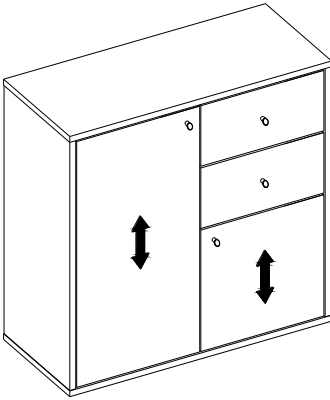

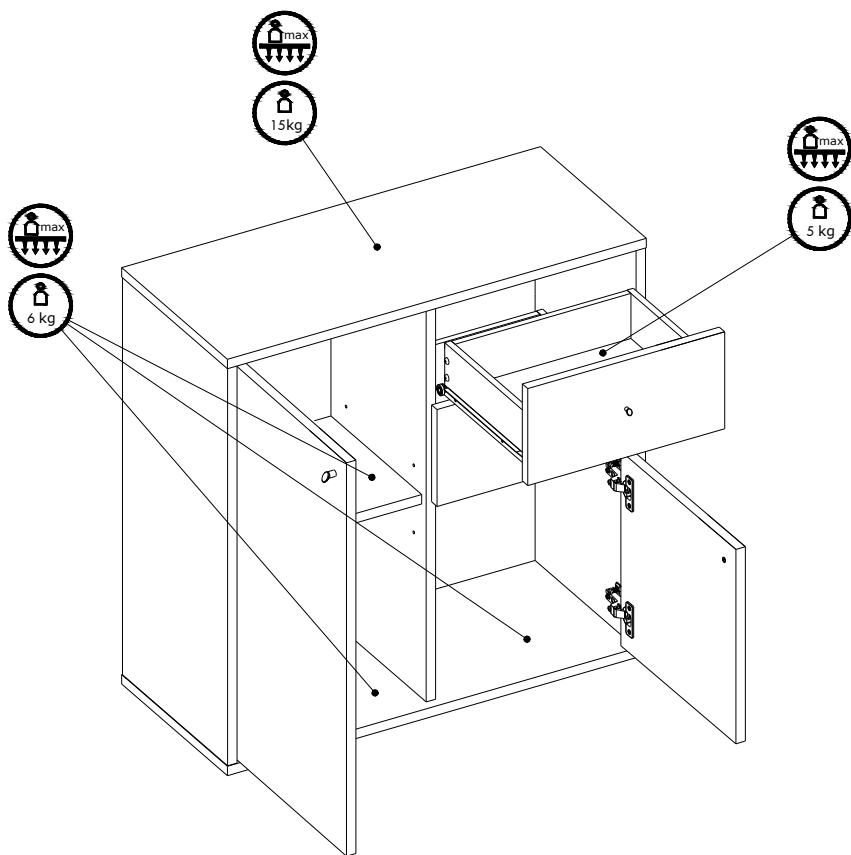

MEBLOMASTER sp. j.  
Zelce I 3a  
07-100 Wegrów  
POLAND

[reklamacje@meblomaster.pl](mailto:reklamacje@meblomaster.pl)  
+48 (25) 740 26 21

MR1521  
08 / 2025

IAN 495559\_2504

