

**GB** **SNORKEL SET**  
Instructions for use

**CZ** **SADA NA ŠNORCHLOVÁNÍ**  
Návod k použití

**DE** **AT** **CH** **SCHNORCHEL-SET**  
Gebrauchsanweisung

**SI** **KOMPLET ZA SNORKLIJANJE**  
Navodilo za uporabo

**SK** **SÚPRAVA NA POTÁPANIE**  
Navod na používanie

**CE**  
EN16805:2015

**GB** **SI** **CZ**

**SK** **DE** **AT** **CH**



**PDF ONLINE**  
www.lidl-service.com

**DELTA-SPORT HANDELSKONTOR GMBH**  
Wragekamp 6 • 22397 Hamburg  
GERMANY

**CE**  
12/2023  
Delta-Sport-Nr.: ES-13698, ES-13699

**SI**

**CZ** **SK**

**IAN 444579\_2307**

**GB**

**SI**

**CZ** **SK**

**Pritrjevanje dihalke**  
Zataknite pritrčilno sponko dihalke na naglavni trak maske, da bo med potapljanjem z masko in dihalko leta ostala v pravilnem položaju in je ne boste izgubili.

#### Shranjevanje, čiščenje

- Pazite, da steklo maske ne pride v stik z mastjo.
- Po vsaki uporabi očistite masko in dihalko s hladko vodo in pustite, da se dobro posuša.
- Da masko zaščitate pred orositvijo, pred vsako uporabo na suho steklo enakomerno nanesite sredstvo proti orositvi.
- Potem maske na kratko sperite s čisto vodo.
- Če potapljaška maske ne uporabljate, jo shranite v primerini torbi za shranjevanje (ni v obsegu dobave).
- Če izdelka ne uporabljate, ga shranite na suho, čisto mesto pri sobni temperaturi.
- Izdelek čistite le tako, da ga obrišete s suho krpo za čiščenje. POMEMBNO! Nikoli ne čistite z ostrimi čistilnimi sredstvi.

#### Napoki za odlaganje v smeti

Izdelek in embalažni material zavrzite v skladu z veljavnimi lokalnimi predpisi. Embalažni material (kot so npr. vrečke iz folije) hranite izven dosega otrok. Druge informacije o odstranjevanju odpadnega izdelka med odpadke lahko dobite pri svoji občinski ali mestni upravi. Izdelek in embalažo zavrzite okolju prijazno.

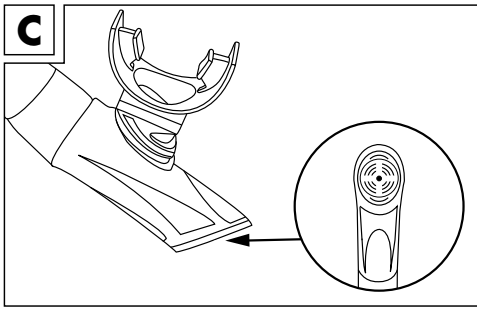
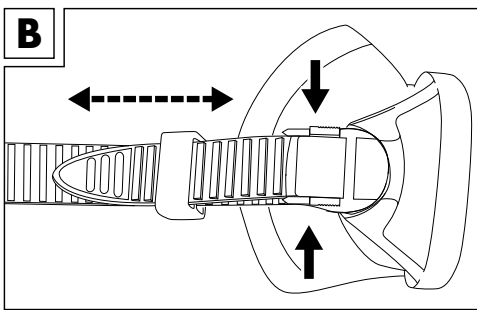
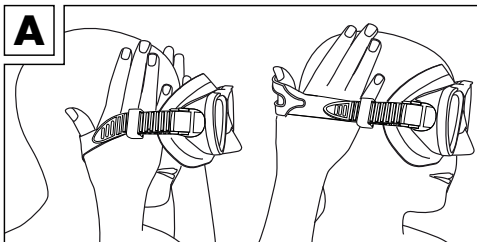

**CE**  
EN16805:2015

**GB** **SI** **CZ**

**SK** **DE** **AT** **CH**

**CE**  
12/2023

**SI**

**CZ** **SK**

#### Transport

In a clean and dry transport container (not included in the scope of delivery).

#### Notes on the guarantee and service handling

The product was produced with great care and under continuous quality control. DELTA-SPORT HANDELSKONTOR GmbH gives private end customers a three-year guarantee on this product from the date of purchase (guarantee period) in accordance with the following provisions. The guarantee is only valid for material and manufacturing defects. The guarantee does not cover parts subject to normal wear and tear that are thus considered wear parts (e.g. batteries) or fragile parts such as switches, rechargeable batteries, or parts made of glass. Claims under this guarantee are excluded if the product has been used incorrectly, improperly, or contrary to the intended purpose, or if the provisions in the instructions for use were not observed, unless the end customer proves that a material or manufacturing defect exists that was not caused by one of the aforementioned circumstances.

**GB**

**SI**

**CZ** **SK**

**CE**  
12/2023

**SI**  
Koda za recikliranje je namenjena označevanju različnih materialov za vrnitev v cikel recikliranja. Koda je sestavljena iz simbola recikliranja za cikel recikliranja in številke, ki označuje material.

#### Transport

V čisti in suhi transportni posodi (ni vsebovana v obsegu dobave).

#### Napoki za garancijo in izvajanje servisne storitve

Izdelek je bil izdelan z veliko skrbnostjo in pod stalno kontrolo. DELTA-SPORT HANDELSKONTOR GmbH zasebnim končnim kupcem od datuma nakupa (garancijskega obdobja) v skladu z naslednjimi določbami odobri triletno garancijo na to postavko. Garancija velja samo za napake v materialu in obdelavi. Garancija ne velja za dele, ki so podvrženi običajni obrabi in jih je zato treba šteti za obrabljive dele (npr. baterije), in za lomljive dele, kot so npr. stikalo, akumulatorji ali deli iz stekla. Zahtevki iz te garancije so izključeni, če je bil izdelek uporabljen nepravilno ali pretirano ali če ni bil uporabljen v okviru predvidenega namena ali predvidenega obsega uporabe ali če niso bile upoštewane specifikacije v navodilih za uporabo, razen če končni kupec lahko dokaže, da gre za napako v materialu ali izdelavi, ki ne temelji na eni od zgoraj navedenih okoliščin.

Congratulations!

You have chosen to purchase a high-quality product. Familiarise yourself with the product before using it for the first time.

**Read the following instructions for use carefully.**

Use the product only as described and only for the given areas of application. Store these instructions for use carefully. When passing the product on to third parties, please also hand over all accompanying documents.

#### Package contents

1 x diving mask  
1 x snorkel  
1 x instructions for use

#### Intended use

Snorkel starter kit. The product is intended for private use.

### ⚠ Safety information

PLEASE RETAIN ALL SAFETY INFORMATION AND INSTRUCTIONS FOR FUTURE REFERENCE. CAUTION! RISK OF INJURY!

## WARNING.

**Do not use for extensive periods of swimming or swimming training.**

- Do not extend the snorkel under any circumstances. This could pose a life-threatening danger of unconsciousness, suffocation or negative pressure in the lungs.**
- It is essential to read the instructions thoroughly before use and observe this information at all times when using the equipment.**
- Never leave children unattended with the packing materials. There is a risk of suffocation.**
- Check the product for damage and wear before each use. The product may only be used in good order and condition!
- Do not expose the product to temperatures below 5 °C or above 40 °C. The product is not intended as protection against mechanically influenced hazards.
- Children should only use this product under adult supervision.
- Do not continue to use the product in the event of skin or eye irritation.
- In accordance with standard EN1972:2015 Class A, the snorkel is designed for people with high lung capacity (for example, adults).

**CE**  
Date of manufacture (month/year): 12/2023

Tempered glass: safety glass

**UK CA**  
UK Conformity Assessed

**CE**  
Date of manufacture (month/year): 12/2023

Tempered glass: safety glass

**SI**

**CZ** **SK**

**CE**  
12/2023

**SI**

**CE**  
Date of manufacture (month/year): 12/2023

Tempered glass: safety glass

**SI**

**CZ** **SK**

**CE**  
12/2023

**SI**

**CZ** **SK**

**CE**  
12/2023

**SI**

**CZ** **SK**

**CE**  
12/2023

**SI**

**CZ** **SK**

**CE**  
12/2023

**SI**

**CZ** **SK**

**CE**  
12/2023

**SI**

**CZ** **SK**

**CE**  
12/2023

**SI**

**CZ** **SK**

**CE**  
12/2023

**SI**

**CZ** **SK**

**CE**  
12/2023

**SI**

**CZ** **SK**

**CE**  
12/2023

**SI**

**CZ** **SK**

**CE**  
12/2023

**SI**

**CZ** **SK**

**CE**  
12/2023

**SI**

**CZ** **SK**

The full declaration of conformity is available under http://www.conformity.delta-sport.com/ Tested at TÜV RHEINland LGA Products GmbH, Tillystr. 2, D-90431 Nürnberg, Germany

**UK CA**  
UK Conformity Assessed

**CE**  
Date of manufacture (month/year): 12/2023

Tempered glass: safety glass

**SI**

**CZ** **SK**

**CE**  
12/2023

**SI**

**CZ** **SK**

**CE**  
12/2023

**SI**

**CZ** **SK**

**CE**  
12/2023

**SI**

**CZ** **SK**

**CE**  
12/2023

**SI**

**CZ** **SK**

**CE**  
12/2023

**SI**

**CZ** **SK**

**CE**  
12/2023

**SI**

**CZ** **SK**

**CE**  
12/2023

**SI**

**CZ** **SK**

**CE**  
12/2023

**SI**

**CZ** **SK**

**CE**  
12/2023

**SI**

**CZ** **SK**

**CE**  
12/2023

**SI**

**CZ** **SK**

**CE**  
12/2023

**SI**

**CZ** **SK**

**CE**  
12/2023

**SI**

**CZ** **SK**

**CE**  
12/2023

**SI**

**CZ** **SK**

**CE**  
12/2023

**SI**

**CZ** **SK**

**CE**  
12/2023

**SI**

**CZ** **SK**

**CE**  
12/2023

**SI**

**CZ** **SK**

**CE**  
12/2023

**SI**

**CZ** **SK**

**CE**  
12/2023

**SI**

**CZ** **SK**

#### General use

**Mask:** Allows the wearer to see while snorkelling and protects the eyes from coming into direct contact with water.

**Snorkel:** Allows the snorkeller to breathe on the surface of the water whilst keeping their head submerged.

To use the snorkel properly, the head must be kept in a horizontal position and the snorkel must project upwards in a vertical position. Only use the snorkel in water.

#### Wearing the mask (Fig. A)

Check the mask fits properly by pressing it against your face (without using the headband) and create a vacuum by breathing in gently through the nose. The mask should remain attached to your face by itself as you hold your breath.

- Hold the mask in front of your face with two hands. The mask should be in your palms with the headband over the back of your hands.
- Now carefully pull the headband around the back of your head.

**Note:** Ensure that the headband is at an angle of approx. 45° to your crown when it sits on your forehead. This is to prevent the ingress of water.

- Adjust the positioning of the headband if required.

**CE**  
Date of manufacture (month/year): 12/2023

Tempered glass: safety glass

**SI**

**CZ** **SK**

**CE**  
12/2023

**SI**

**CZ** **SK**

**CE**  
12/2023

**SI**

**CZ** **SK**

**CE**  
12/2023

**SI**

**CZ** **SK**

**CE**  
12/2023

**SI**

**CZ** **SK**

**CE**  
12/2023

**SI**

**CZ** **SK**

**CE**  
12/2023

**SI**

**CZ** **SK**

**CE**  
12/2023

**SI**

**CZ** **SK**

**CE**  
12/2023

**SI**

**CZ** **SK**

**CE**  
12/2023

**SI**

**CZ** **SK**

**CE**  
12/2023

**SI**

**CZ** **SK**

**CE**  
12/2023

**SI**

**CZ** **SK**

**CE**  
12/2023

**SI**

**CZ** **SK**

**CE**  
12/2023

**SI**

**CZ** **SK**

**CE**  
12/2023

**SI**

**CZ** **SK**

**CE**  
12/2023

#### Adjusting the headband (Fig. B)

Adjust the headband so that it sits comfortably and does not slip.

- Pull the two ends of the headband evenly until the mask sits securely and comfortably.
- To loosen the mask, press the two adjustment buttons with your thumb and index finger and pull the headband back.

#### Removing water

Take the mask in both hands and tip it forwards so that the water can escape. If any water enters the snorkel in spite of the splash guard, you can remove this with a short, sharp blow into the mouthpiece (Fig. C).

#### Removing the mask

Slide your thumbs underneath the headband on both sides of your head. Run your thumbs around to the back of your head and pull the headband away from the back of your head and above your forehead.

#### Using corrective lenses

If you would like to incorporate corrective lenses into your mask, consult your local retailer or optician.

#### Securing the snorkel

Hook the snorkel fast



