

Regal

(DE) Regal

(AT) Montageanleitung

(CH)

(IT) Scaffale

(CH) Istruzioni per il montaggio

(NL) Rek

(BE) Montagehandleiding

(PT) Estante

Instruções de montagem

(FR) Étagère

(CH) Instructions de montage

(BE)

(GB) Shelf

(IE) Assembly instruction

(ES) Estante

Instrucciones de montaje

(CZ) REGÁL

Montážní návod

IAN 302646



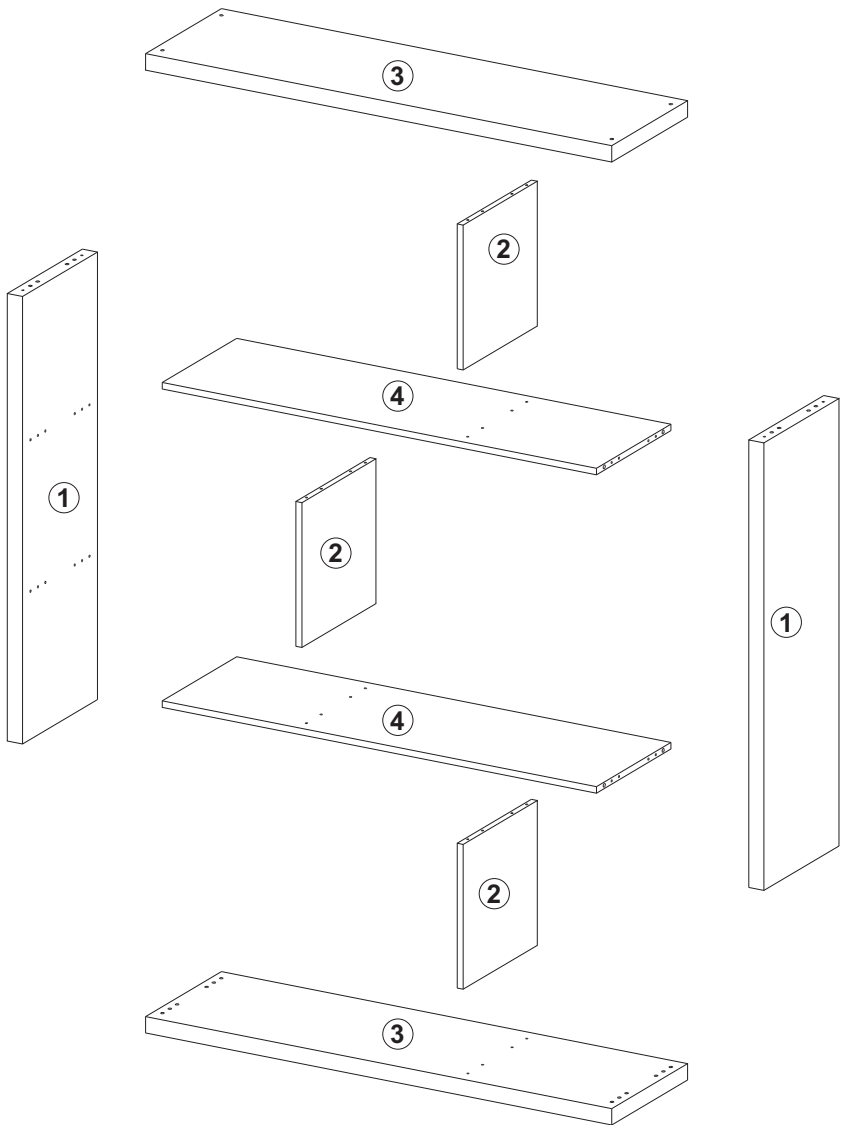

A

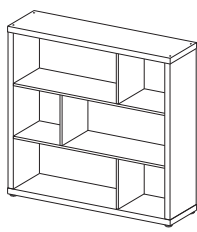

B

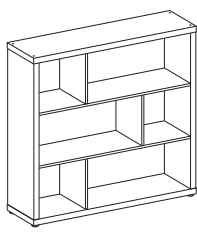

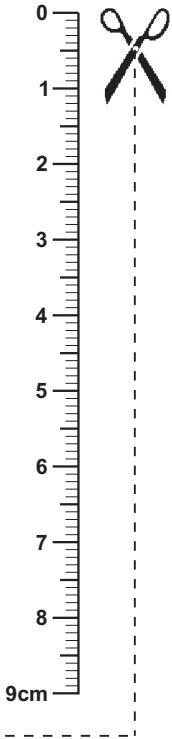

Sie benötigen:
 Vous avez besoin de:
 Le servono:
 You need:
 U hebt nodig:
 Necesita:
 Necesita de:
 Potřebujete:

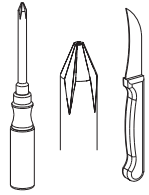
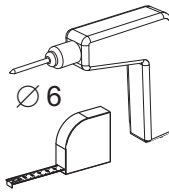
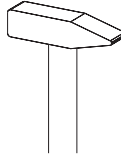

Beschläge / Ferrures pour meubles / Guarnizioni / Fittings
 / Hang- en sluitwerk / Herrajes / Guarnições / Kování

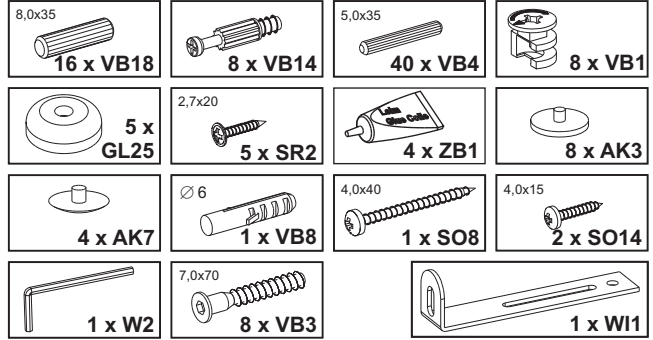

Teile / Pièces / Pezzi / Article/ Onderdelen/ Piezas/ Peças / Dily

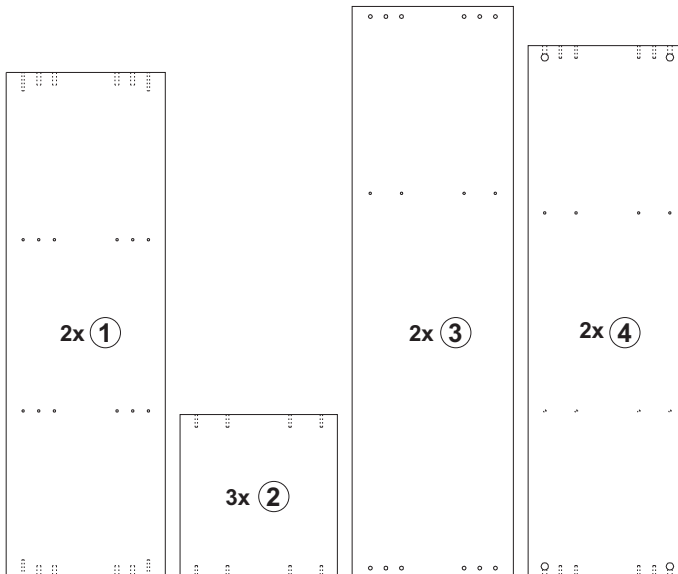

-
- DE** **Sicherheitshinweis:**
Achtung: Bei mangelhafter Montage besteht Gefahr für die Sicherheit. Aufbau durch fachkundiges Personal empfohlen!
- AT**
- CH** **Pflegehinweis:**
Bitte nur mit einem Staubtuch oder einem feuchten Lappen reinigen. Keine scheuernden Putzmittel verwenden!
Bestimmungsgemäße Verwendung:
Produkt nutzbar für den privaten Wohnbereich.
- FR** **Note de sécurité:**
Attention: En cas de montage incorrect, il y a risque pour la sécurité. Installation, recommandée par un personnel expérimentée.
- CH**
- BE** **Note d'entretien:**
Ne nettoyer qu'avec un chiffon à poussière ou un chiffon humide. Ne pas utiliser de produit à récurer !
Utilisation selon destination:
Produit utilisable pour le domaine de séjour privé.
- IT** **Nota di sicurezza:**
Attenzione: Nel caso di montaggio non adeguato c'è pericolo di sicurezza. Si consiglia il montaggio da personale esperto!
- CH**
- Nota di trattamento:**
Per favore pulire solo con un panno per rimuovere polvere o con uno straccio umido. Non usare detergenti abrasivi!
Uso secondo le disposizioni:
Prodotto addato per uso domestico.
- GB** **Safety instructions:**
Warning: Deficient assembly causes safety risks. Assembling by qualified personnel is recommended.
- IE** **Care instructions:**
Please do only clean with a duster or a damp cloth. Do not use any scouring agents!
Intended use:
The appliance is intended for household use.

-
- (NL)** **Veiligheidsinformatie:**
Opgelet: bij een gebrekkige montage bestaat gevaar voor de veiligheid. Montage door deskundig personeel aanbevolen!
- (BE)** **Onderhoudsinformatie:**
A.u.b. alleen reinigen met een stofdoek of een vochtige lap. Gebruik nooit schurende poetsmiddelen!
Gebruik overeenkomstig de bestemming:
Product bruikbaar voor privéwoningen.
- (ES)** **Aviso de seguridad:**
Atención: En caso de montaje incorrecto, existe peligro para la seguridad. ¡Se recomienda recurrir a un personal profesional especializado para efectuar el montaje!
Aviso de cuidado:
Limpiar sólo con un trapo para el polvo o con un trapo húmedo. No utilizar productos de limpieza abrasivos!
Uso conforme a las disposiciones legales:
El producto es utilizable para el área de vivienda privada.
- (PT)** **Aviso de segurança:**
Atenção: Em caso de montagem incorrecta existe perigo relativamente à segurança. É recomendável recorrer a um pessoal profissional especializado para efectuar a montagem!
Aviso de cuidado:
Limpar apenas com um pano suave ou humedecido. Não utilizar qualquer detergente abrasivo!
Uso de acordo com as disposições legais:
O produto é utilizável para a área residencial privada.
- (CZ)** **Bezpečnostní upozornění:**
Pozor: Při chybné montáži vzniká bezpečnostní riziko. Doporučujeme nechat provést montáž specializovaným personálem!
Upozornění o údržbě:
Čistěte, prosím, pouze prachovkou nebo vlhkým hadrem. Nepoužívejte abrazivní čisticí prostředky!
Použití v souladu s účelem:
Výrobek je určen k soukromému domácímu použití.

A

5,0x35



40 x VB4



8 x VB1

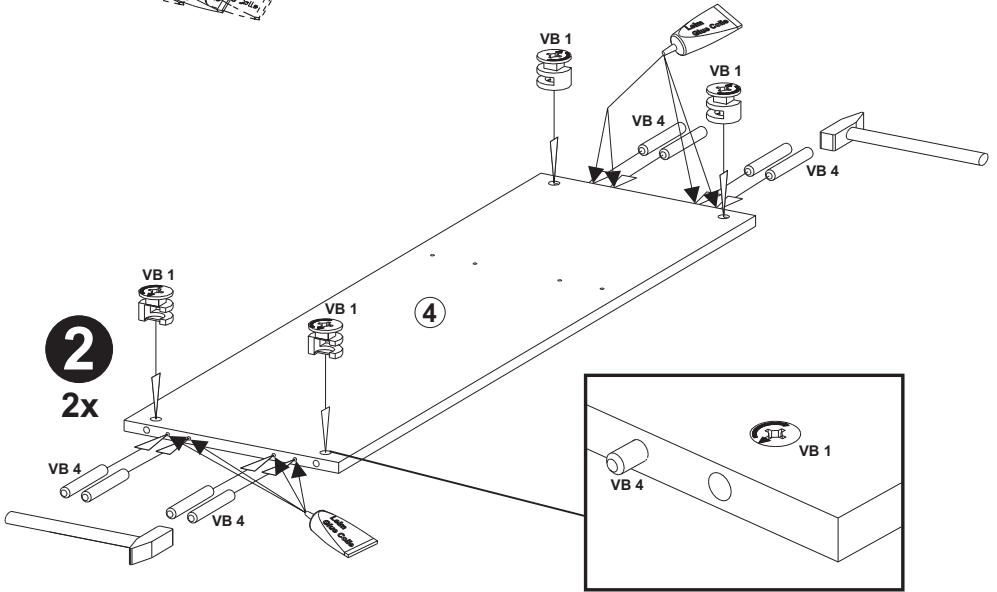
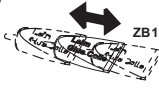

ZB1

1**3**

3x

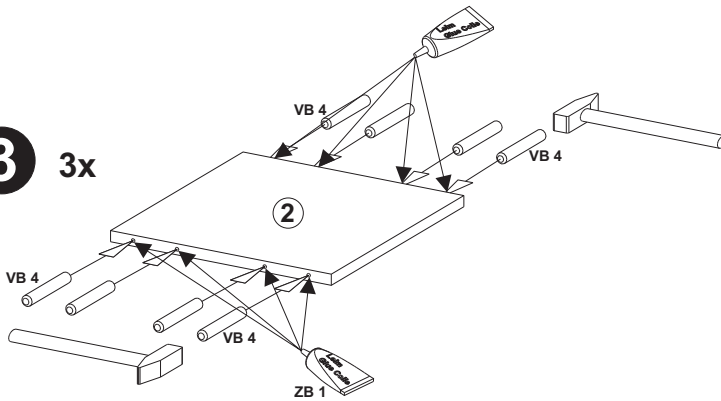

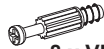
B

8 x VB14

8,0x35



16 x VB18



ZB1

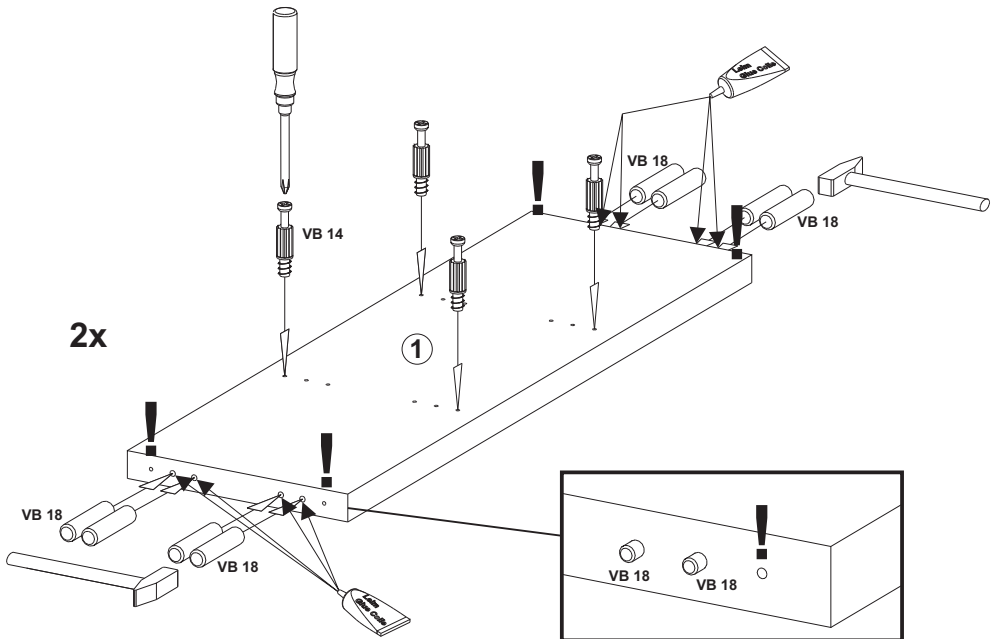

C



ZB1

1 2x

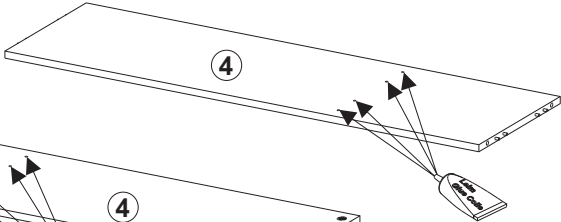

2
2x

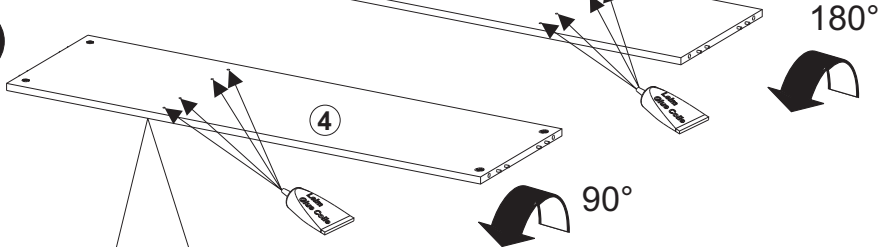

180°



3

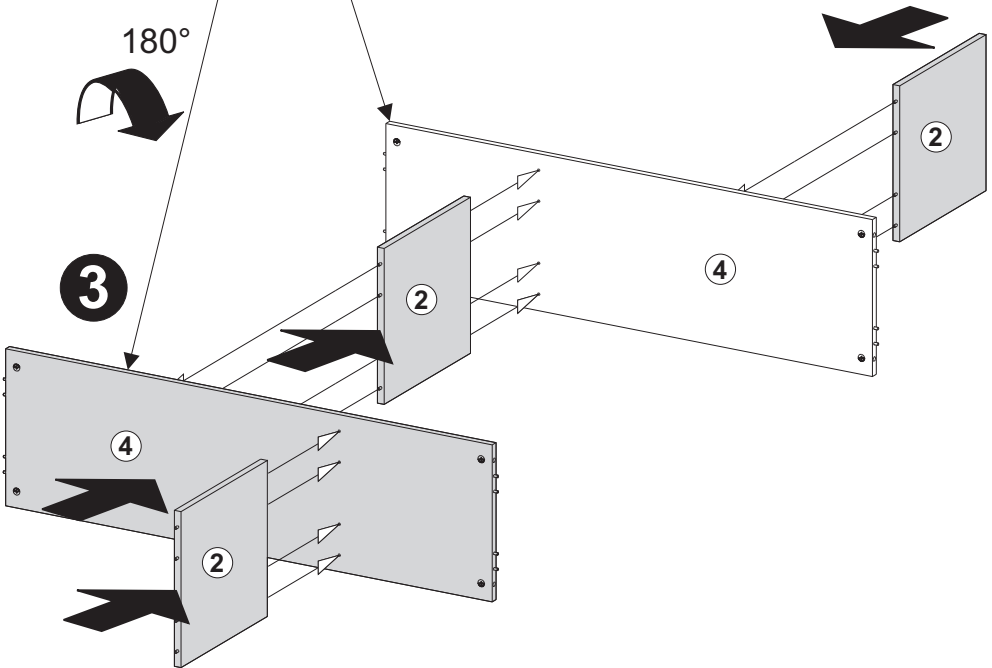

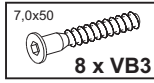
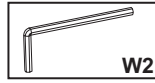
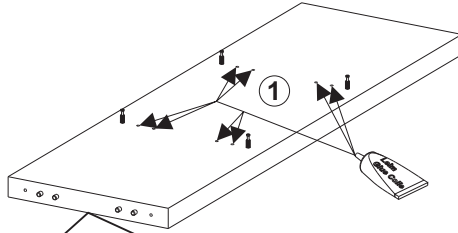
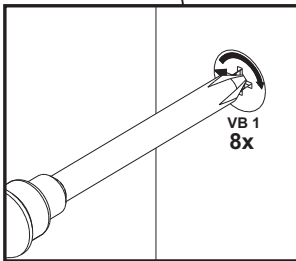
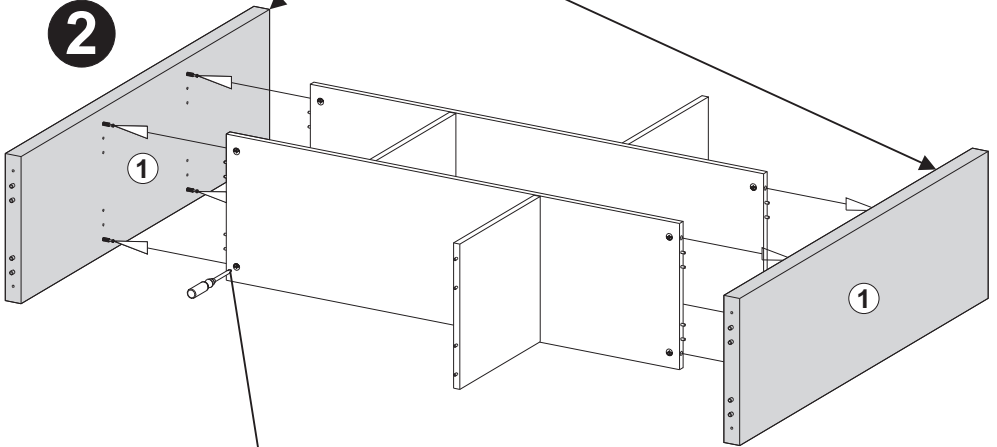
D**1** 2x**2**

E

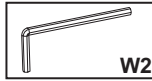

W2

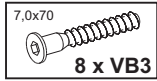

7.0x70

8 x VB3

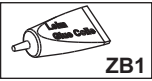

ZB1

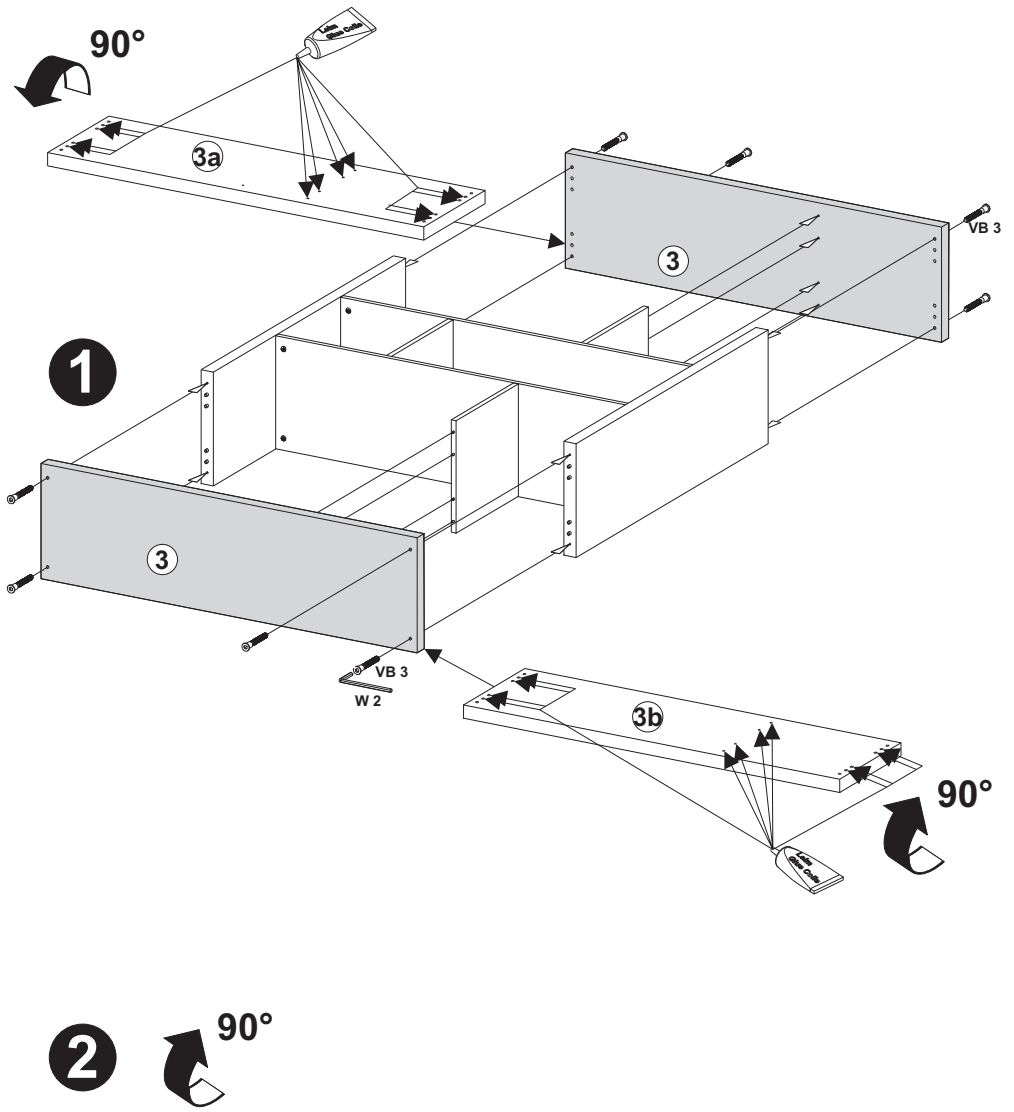

F1

A

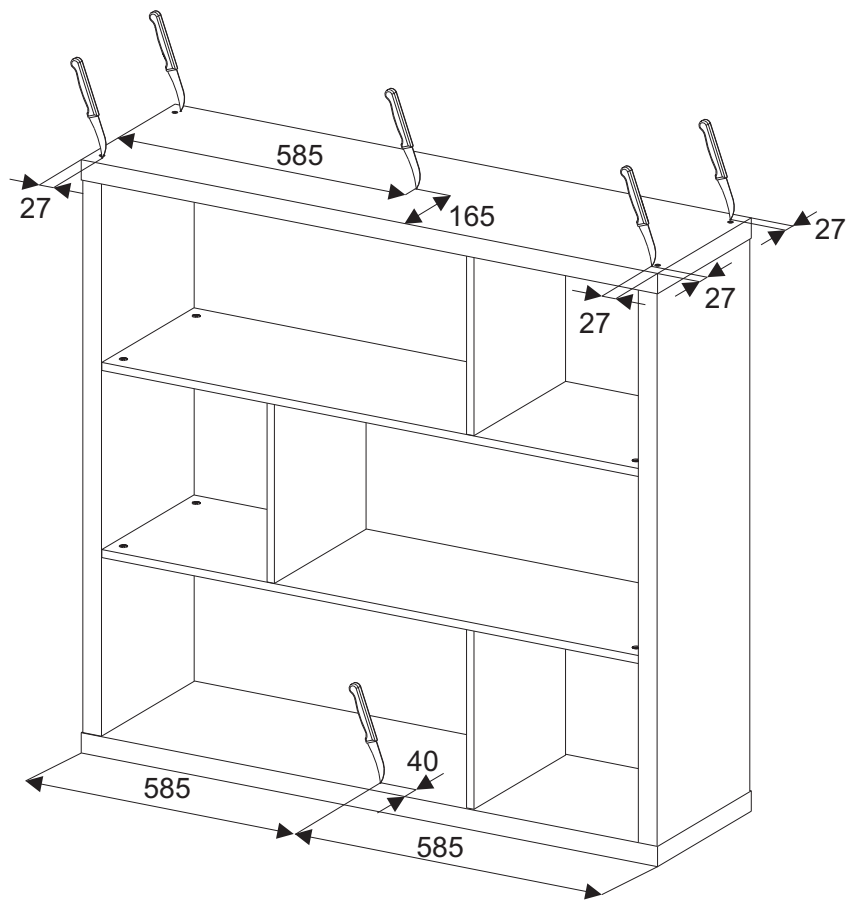
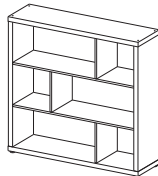

G1

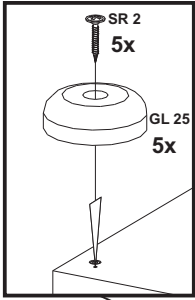
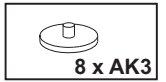
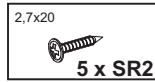
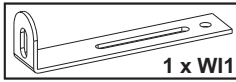

A

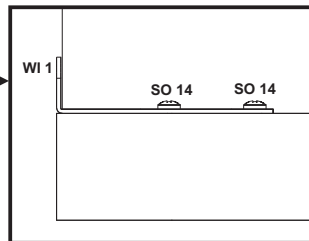
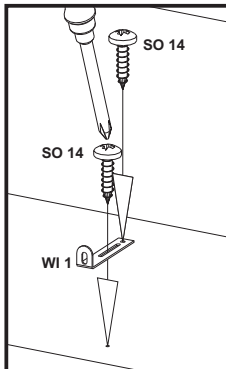
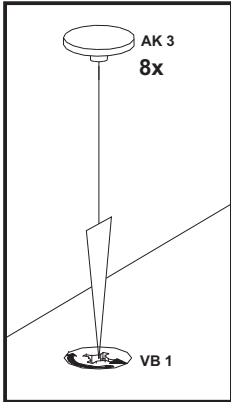
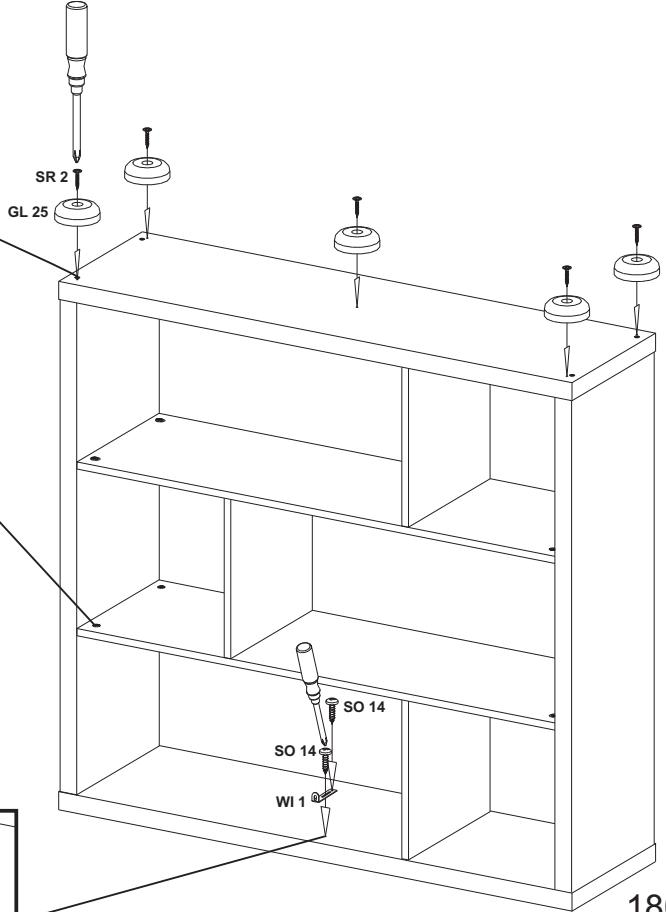
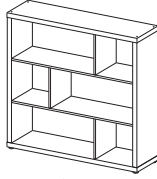

H1

A

4 x AK7

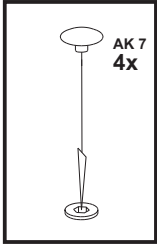
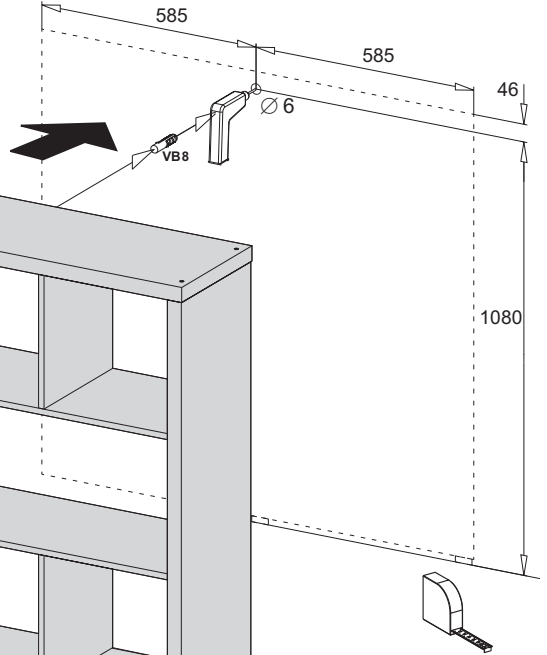
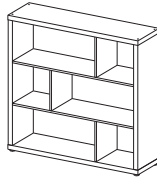

1 x VB8

4,0x40
1 x SO8AK 7
4x

SO 1

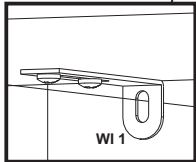

WI 1

(DE) (AT) (CH)**Wandmontage:**

Bei Verbindungsmitteln für die Wandbefestigung ist das Trägermaterial auf Eignung zu prüfen.

Um ein Umkippen zu verhindern, ist dieses Produkt mit der mitgelieferten Wandbefestigung zu verwenden.

(FR) (CH) (BE)**Montage mural:**

Um ein Umkippen zu verhindern, ist dieses Produkt mit der mitgelieferten Wandbefestigung zu verwenden.

Pour éviter tout basculement, utilisez ce produit avec le support mural fourni.

(IT) (CH)**Montaggio su parete:**

Nel caso di mezzi di connessione per il fissaggio della parete il materiale portante deve essere esaminato in vista della sua idoneità.

Per evitare ribaltamenti, utilizzare questo prodotto con il supporto da parete in dotazione.

(GB) (IE)**Wall fixing:**

In case of connective devices for the wall mounting, the supporting material must be checked for suitability.

To prevent tipping over, use this product with the supplied wall bracket.

H1

A

4 x AK7

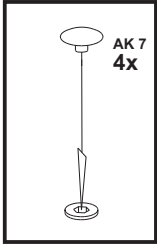
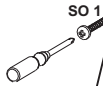
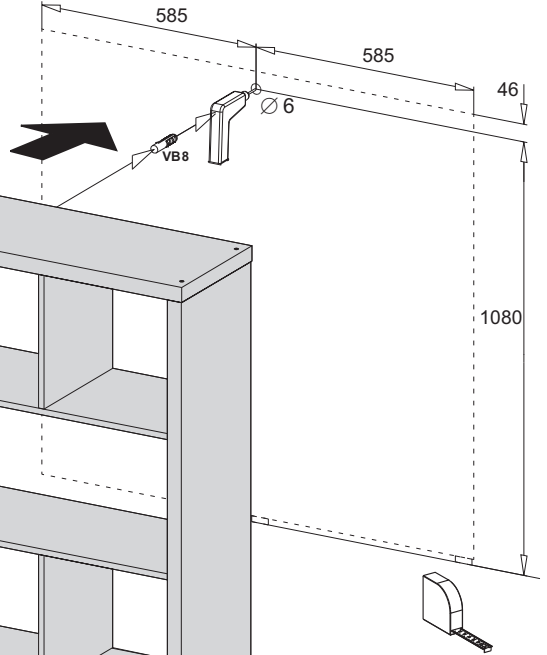
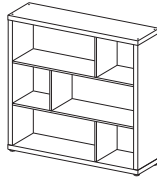

1 x VB8

4,0x40
1 x SO8AK 7
4x

SO 1

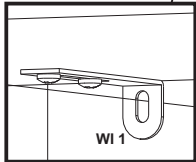

WI 1

(NL) (BE)**Wandmontage:**

Bij verbindingsmiddelen voor de wandbevestiging moet de geschiktheid van het dragermateriaal worden gecontroleerd.

Gebruik dit product samen met de bijgeleverde muurbeugel om kantelen te voorkomen.

(ES)**Montaje en pared:**

Al emplear material de unión para la fijación de paredes, debe comprobarse la idoneidad del material de soporte.

Para evitar que se vuelque, utilice este producto con el soporte de pared suministrado.

(PT)**Montagem em parede:**

Em caso de meios de ligação para a fixação na parede, o material de suporte deve ser verificado quando à aptidão.

Para evitar que tombe, este produto deve ser usado com o suporte de parede fornecido.

(CZ)**Montáž na stěnu:**

U spojovacích prostředku určených k montáži na stěnu je nezbytné zkontrolovat vhodnost nosného materiálu.

Para evitar que tombe, este produto deve ser usado com o suporte de parede fornecido.

F2

B

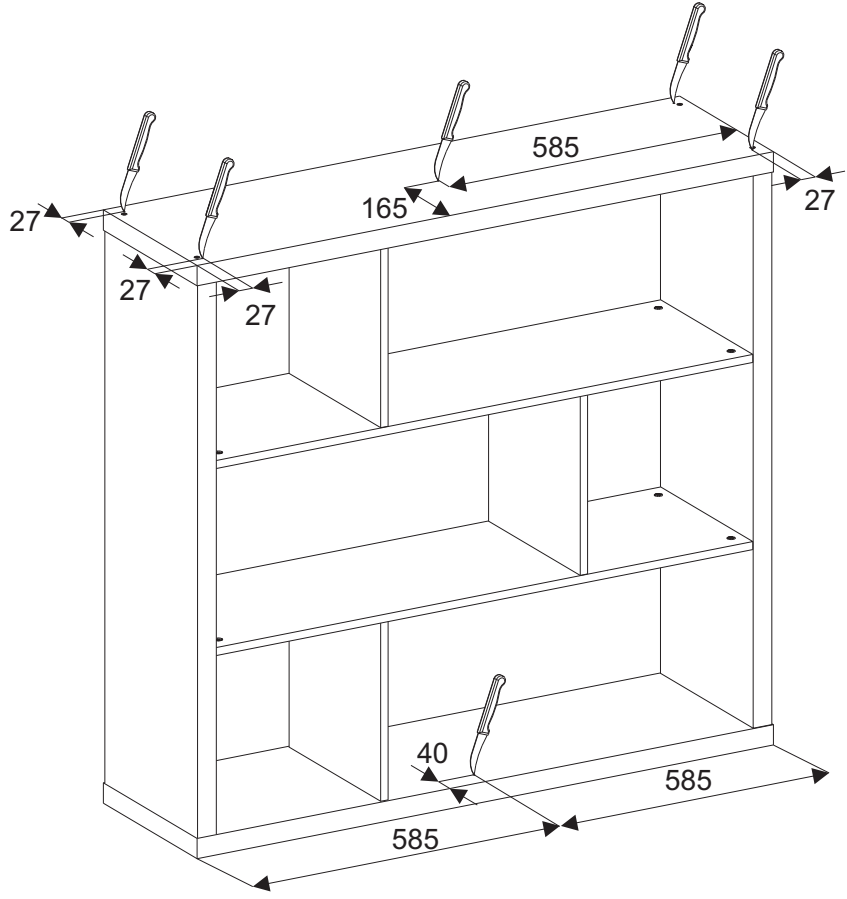
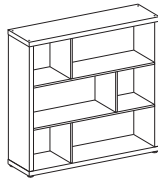

G2

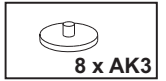
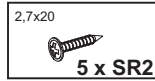
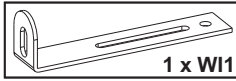

B

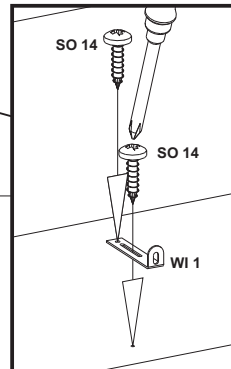
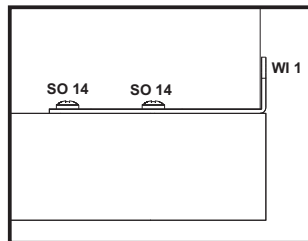
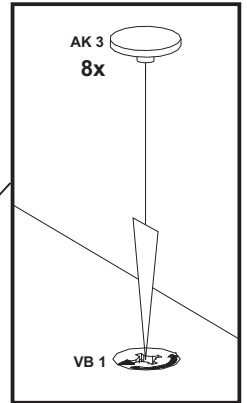
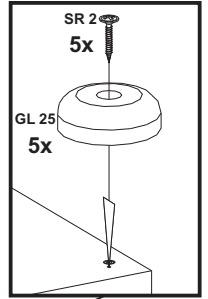
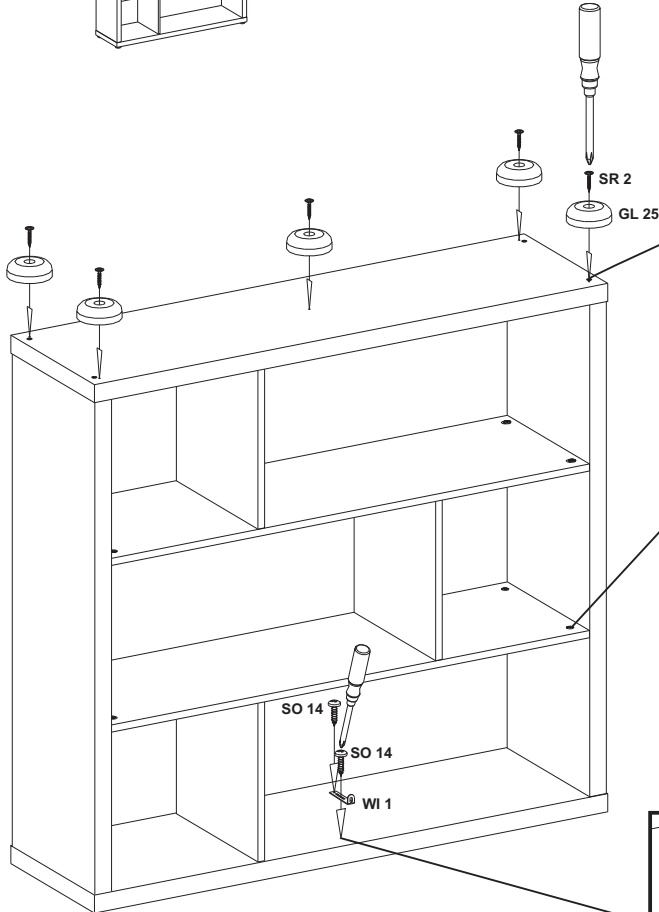
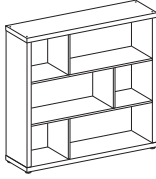

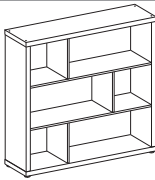
H2**B**

4 x AK7

∅ 6



1 x VB8

4,0x40

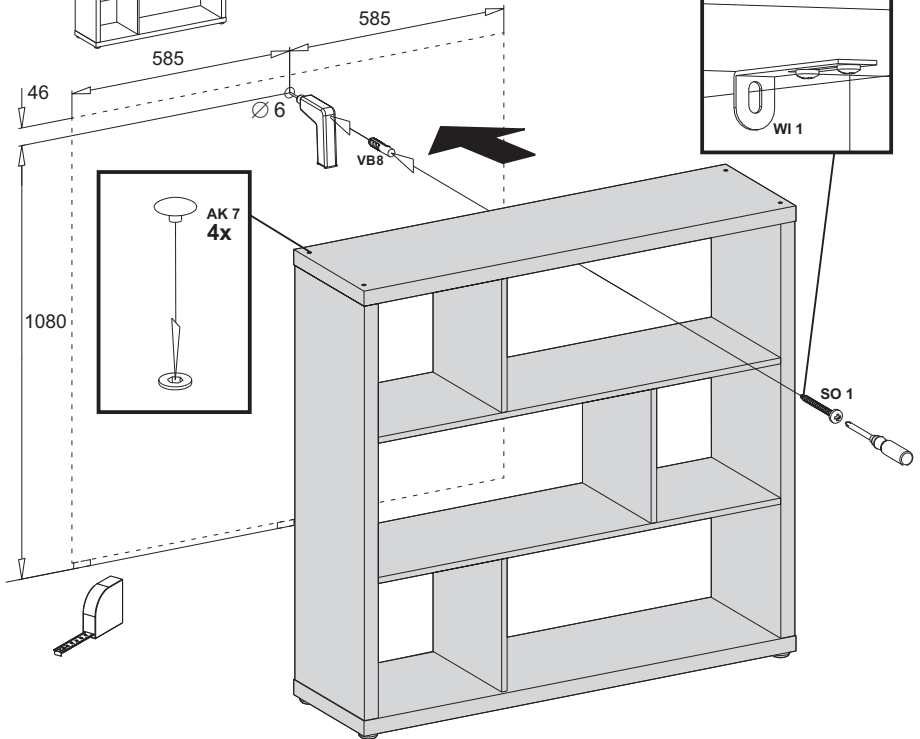

1 x SO8

**(DE) (AT) (CH)****Wandmontage:**

Bei Verbindungsmitteln für die Wandbefestigung ist das Trägermaterial auf Eignung zu prüfen.

Um ein Umkippen zu verhindern, ist dieses Produkt mit der mitgelieferten Wandbefestigung zu verwenden.

(FR) (CH) (BE)**Montage mural:**

Um ein Umkippen zu verhindern, ist dieses Produkt mit der mitgelieferten Wandbefestigung zu verwenden.

Pour éviter tout basculement, utilisez ce produit avec le support mural fourni.

(IT) (CH)**Montaggio su parete:**

Nel caso di mezzi di connessione per il fissaggio della parete il materiale portante deve essere esaminato in vista della sua idoneità.

Per evitare ribaltamenti, utilizzare questo prodotto con il supporto da parete in dotazione.

(GB) (IE)**Wall fixing:**

In case of connective devices for the wall mounting, the supporting material must be checked for suitability.

To prevent tipping over, use this product with the supplied wall bracket.

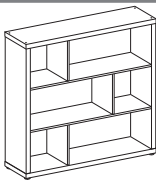
H2**B**

4 x AK7

∅ 6



1 x VB8

4,0x40

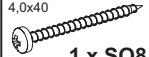

1 x SO8

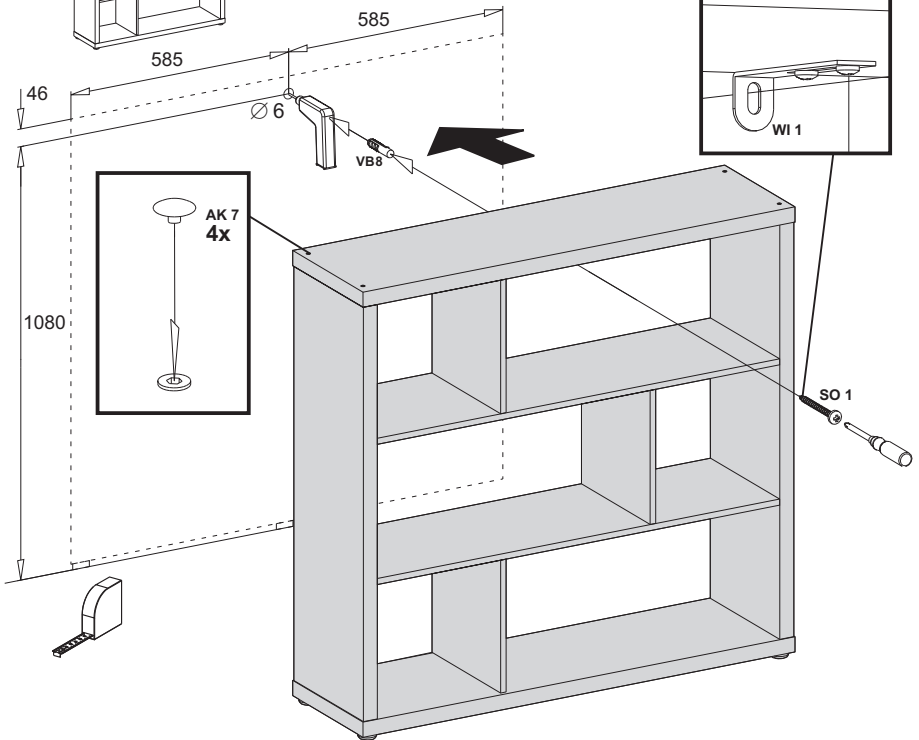
**(NL) (BE)****Wandmontage:**

Bij verbindingsmiddelen voor de wandbevestiging moet de geschiktheid van het dragermateriaal worden gecontroleerd.

Gebruik dit product samen met de bijgeleverde muurbeugel om kantelen te voorkomen.

(ES)**Montaje en pared:**

Al emplear material de unión para la fijación de paredes, debe comprobarse la idoneidad del material de soporte.

Para evitar que se vuelque, utilice este producto con el soporte de pared suministrado.

(PT)**Montagem em parede:**

Em caso de meios de ligação para a fixação na parede, o material de suporte deve ser verificado quando à aptidão.

Para evitar que tombe, este produto deve ser usado com o suporte de parede fornecido.

(CZ)**Montáž na stěnu:**

U spojovacích prostředku určených k montáži na stěnu je nezbytné zkontrolovat vhodnost nosného materiálu.

Para evitar que tombe, este produto deve ser usado com o suporte de parede fornecido.

FMD Möbel GmbH
Heidländer Weg 68
D-49201 Dissen a.T.W.
@ service@fmd-moebel.de
☎ +49 5421 9448-44

IAN 302646

