



ALU-INSEKTENSCHUTZ-TÜR

ALU-INSEKTENSCHUTZ-TÜR
Montage- und Sicherheitshinweise

MOUSTIQUAIRE DE PORTE EN ALUMINIUM
Instructions de montage et consignes de sécurité

ALUMINIUM HORDEUR
Montage- en veiligheidsinstructies

ALUMINIUM DOOR INSECT SCREEN
Installation and safety instructions

OCHRANA NA DVĚRE PROTÍ HMYZU
Montážní a bezpečnostní pokyny

PORTA DE ALUMÍNIO PARA PROTEÇÃO CONTRA INSETOS
Indicações de montagem e segurança

RAMA ALUMINIOWA NA DRZWI PRZECIŃ OWADOM
Wskazówki dotyczące montażu i bezpieczeństwa

ALUMINIUS DURU APSAUGOS TINKLEIS NUO VABZŲIU
Montavimo ir saugos nurodymai

SZŰNYOGHÁLÓS ALUMINIUM AJTÓ
Szerelési és biztonsági útmutató

ALUMINIJASTA VRATNA ZAŠČITA PRED MRČESOM
Navodila za montažo in varnostni napotki

HĹINIKOVÁ OCHRANA PROTÍ HMYZU
Montážne a bezpečnostné pokyny

ALUMINIJSKI OKVIR ZA VRATA SA ZAŠTITOM OD INSEKATA
Napomene o montaži i sigurnosti

ALUMINIUMSKI OKVIR ZA VRATA SA ZAŠTITOM OD INSEKATA
Uputstva za montažu i bezbednosne napomene

HYÖNTESUOJA OVEEN
Asennus- ja turvaohjeet

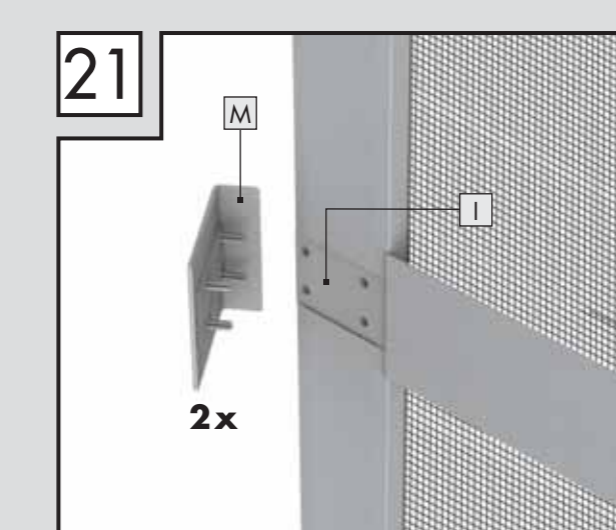
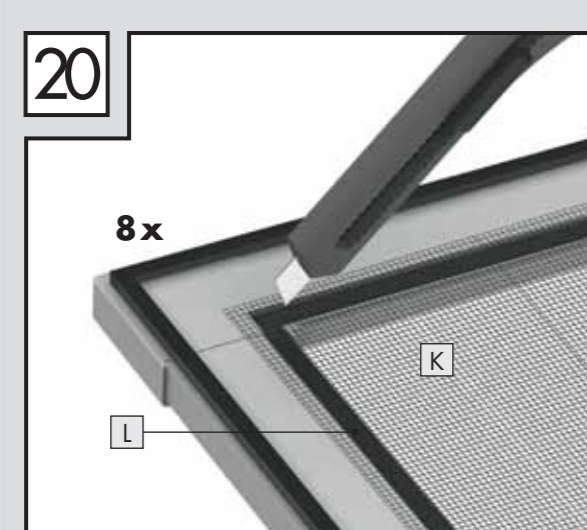
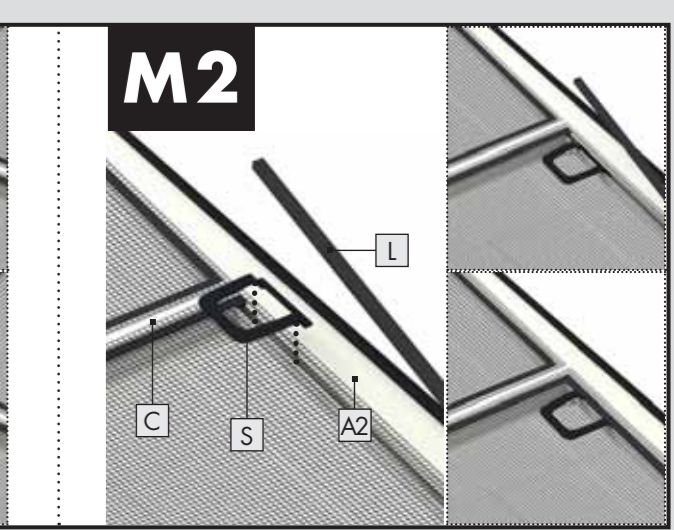
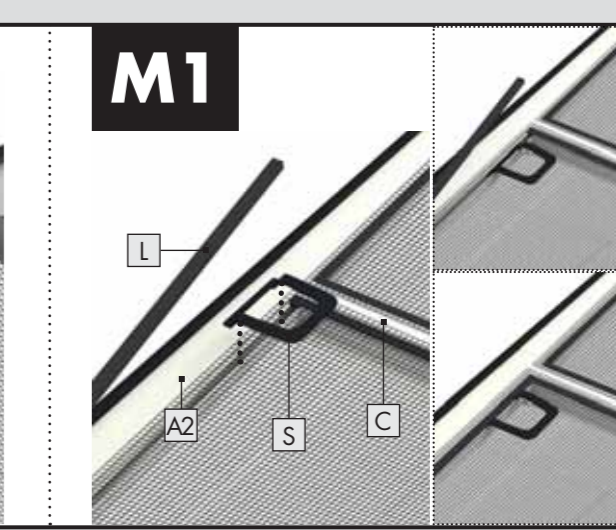
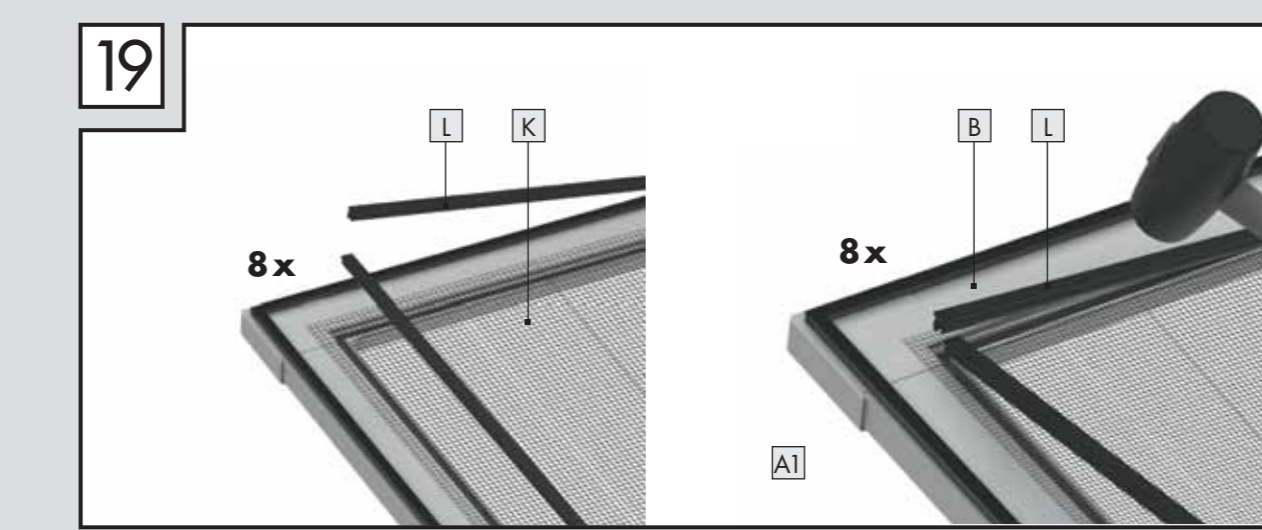
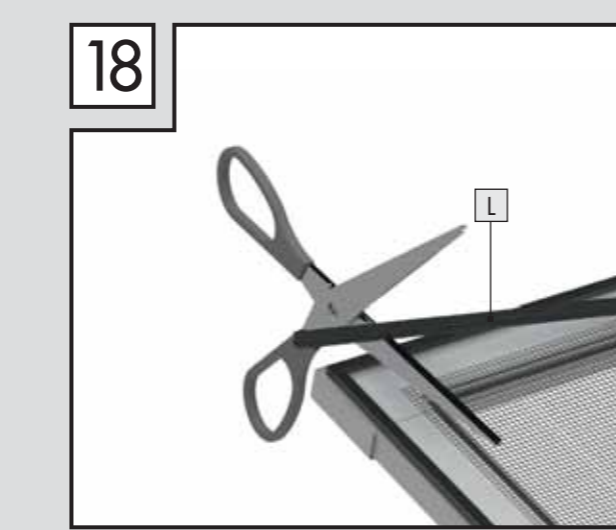
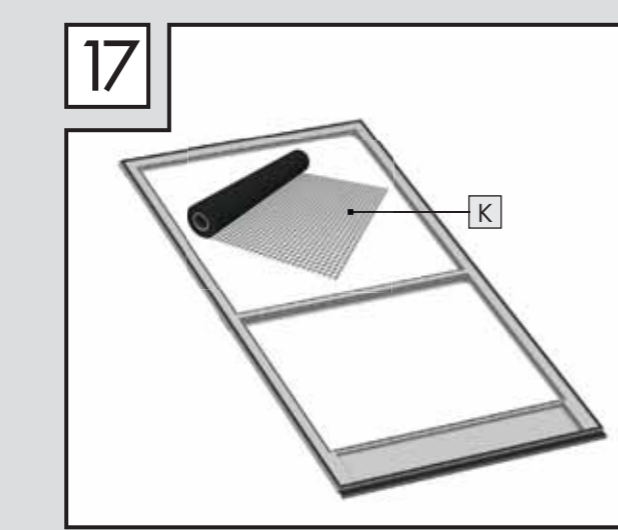
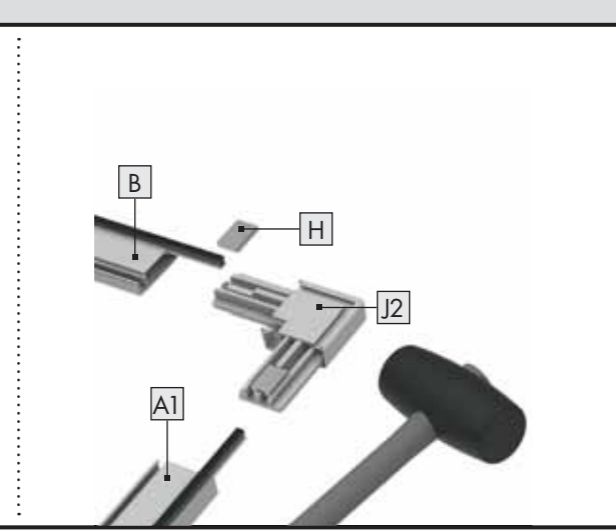
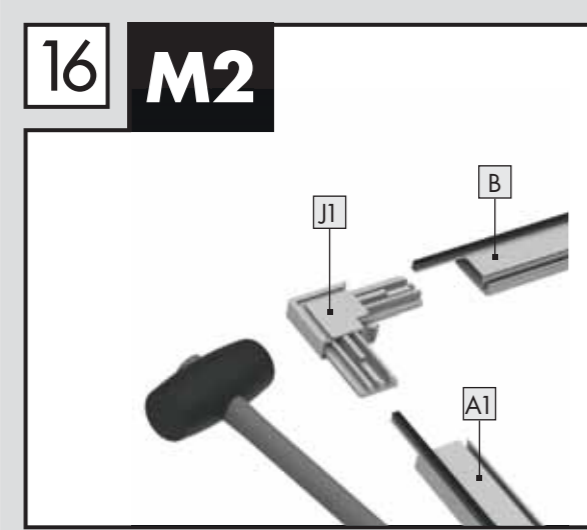
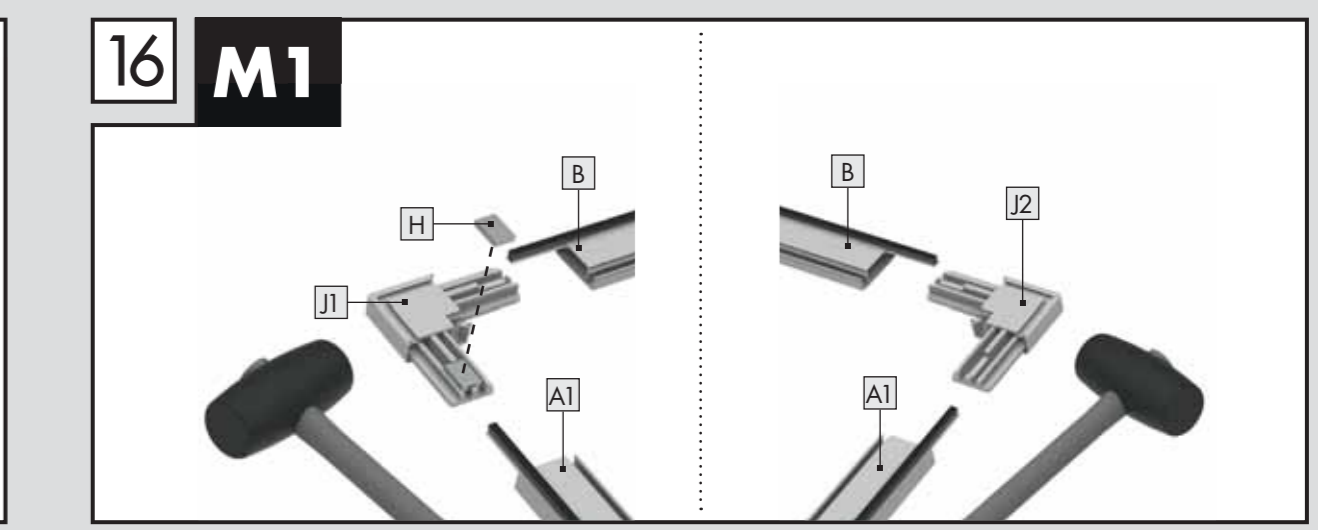
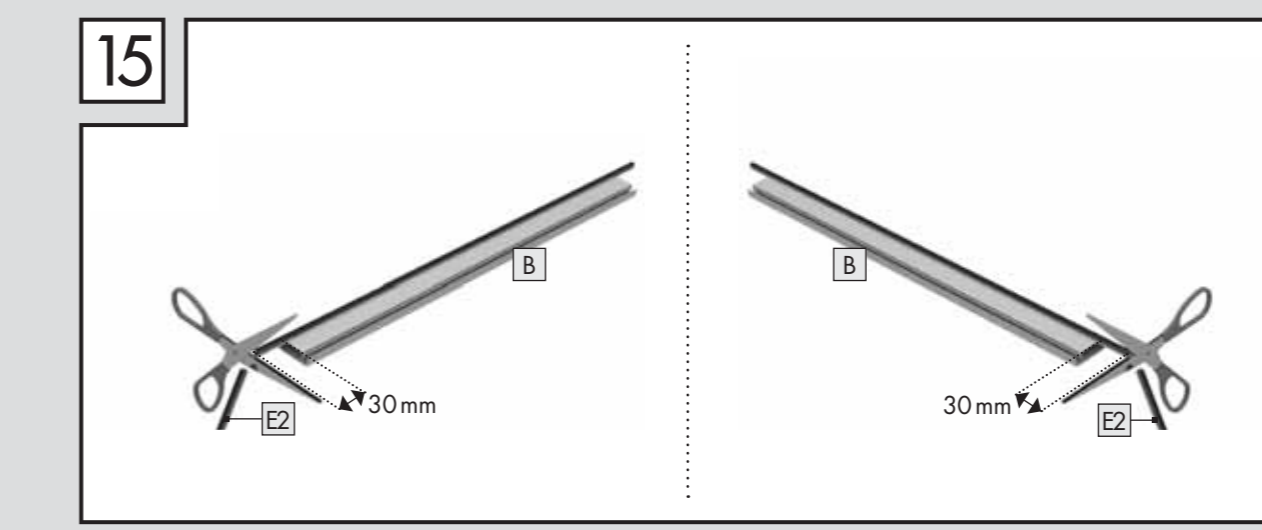
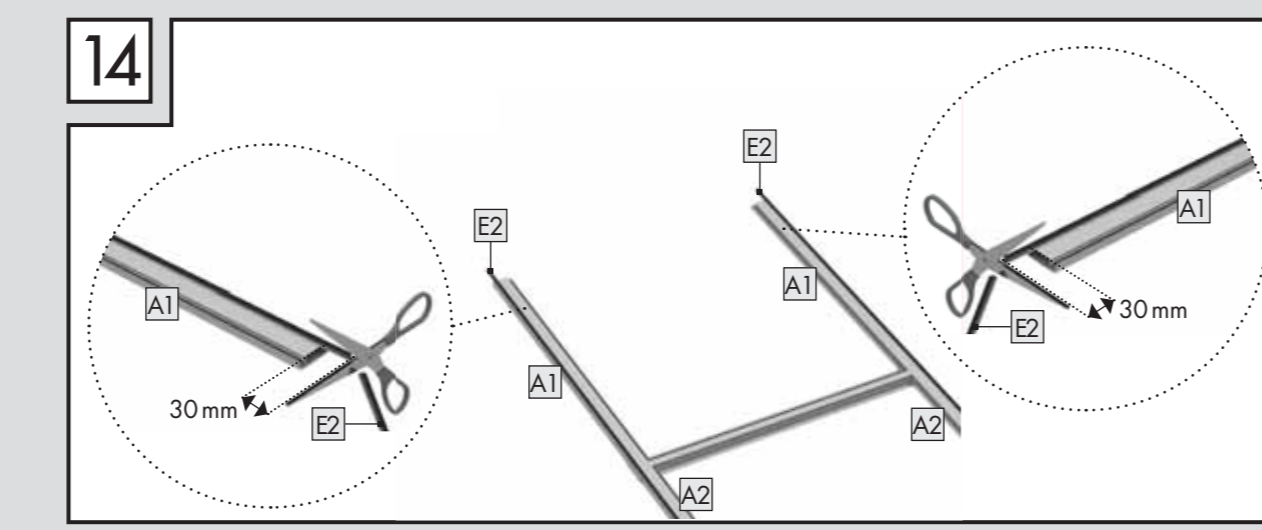
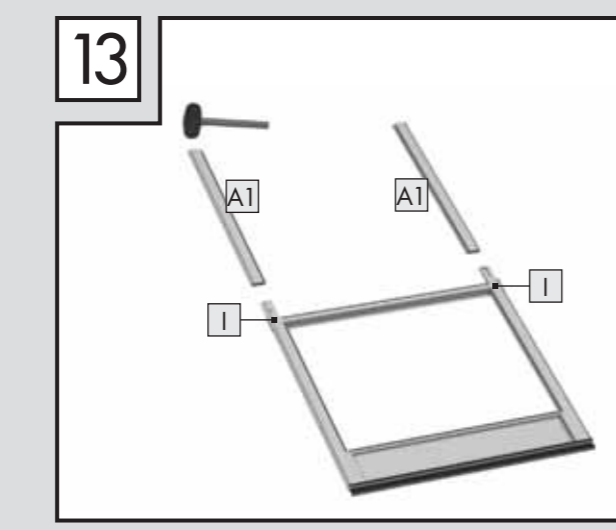
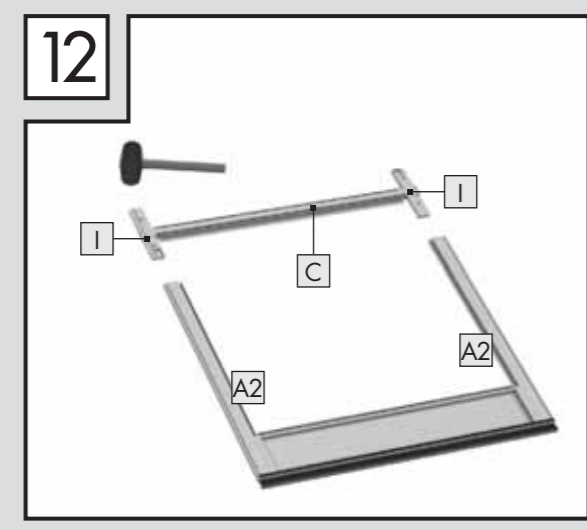
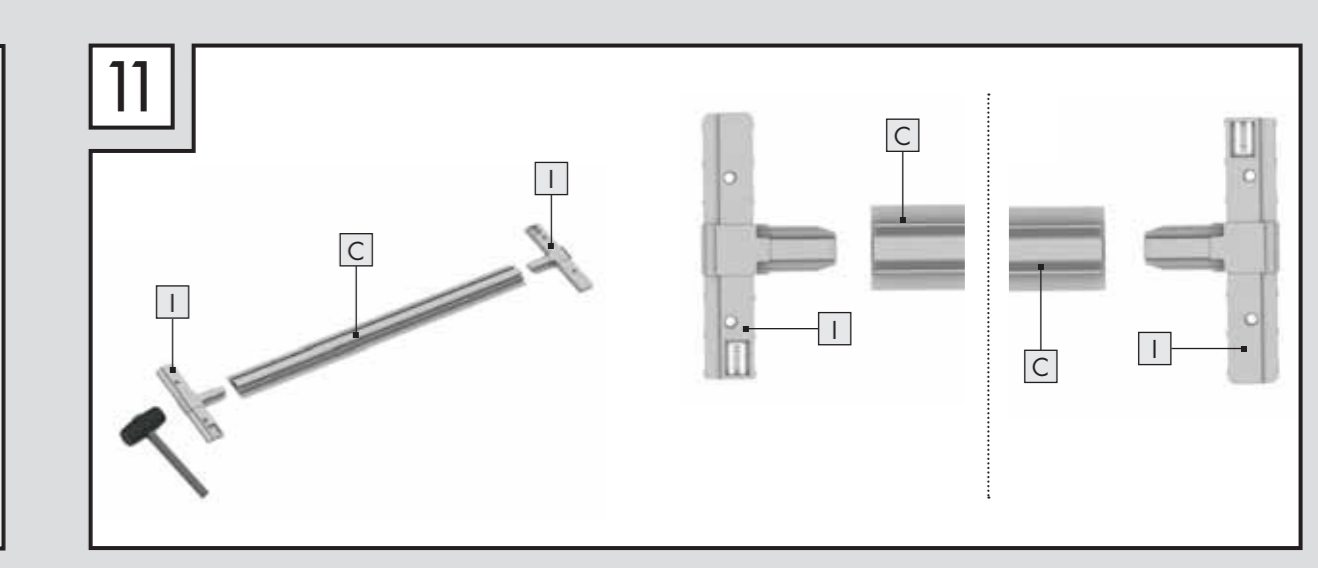
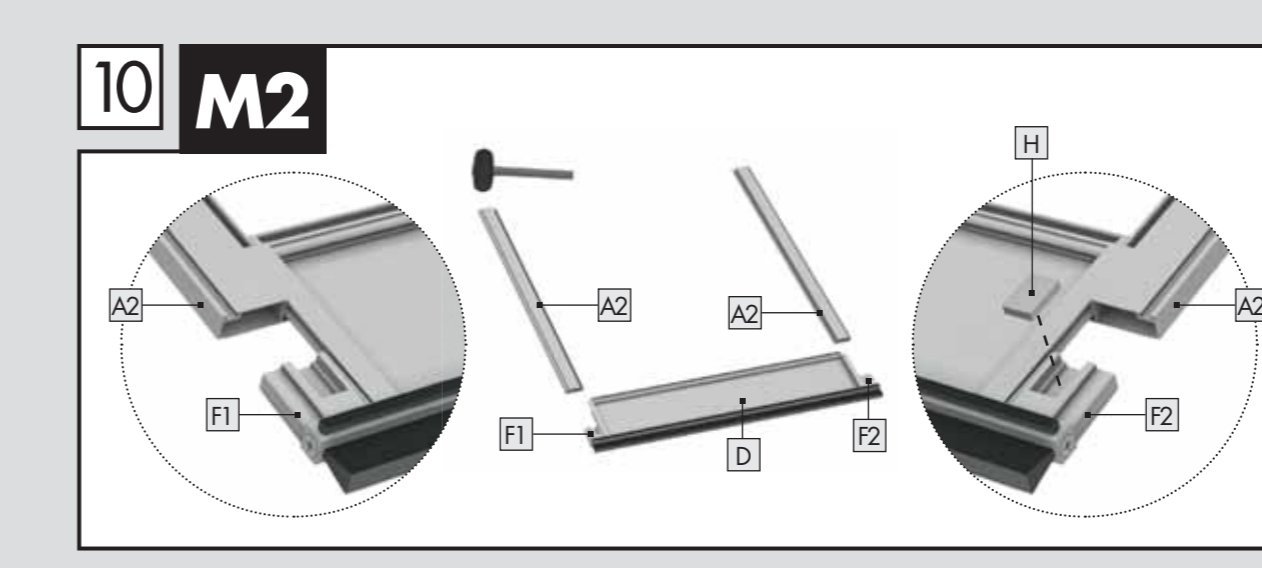
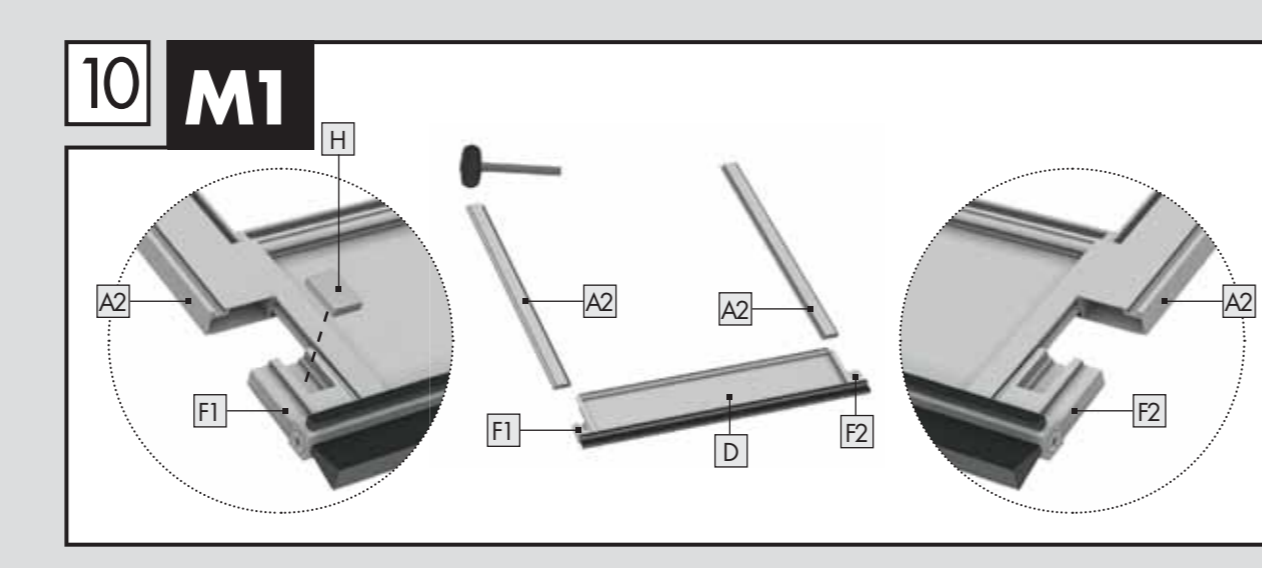
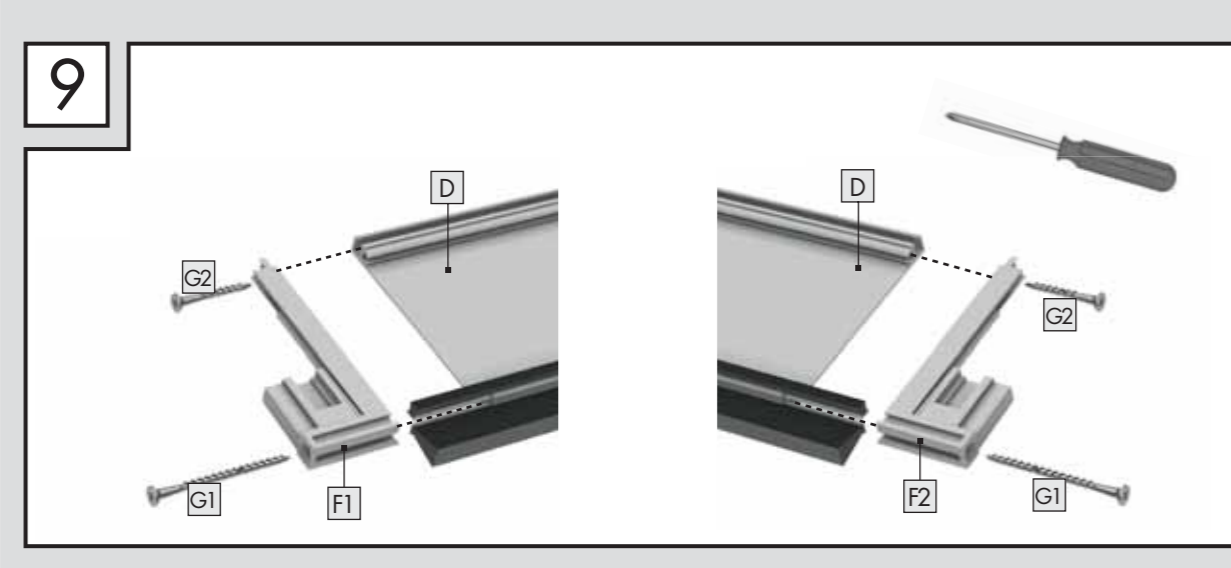
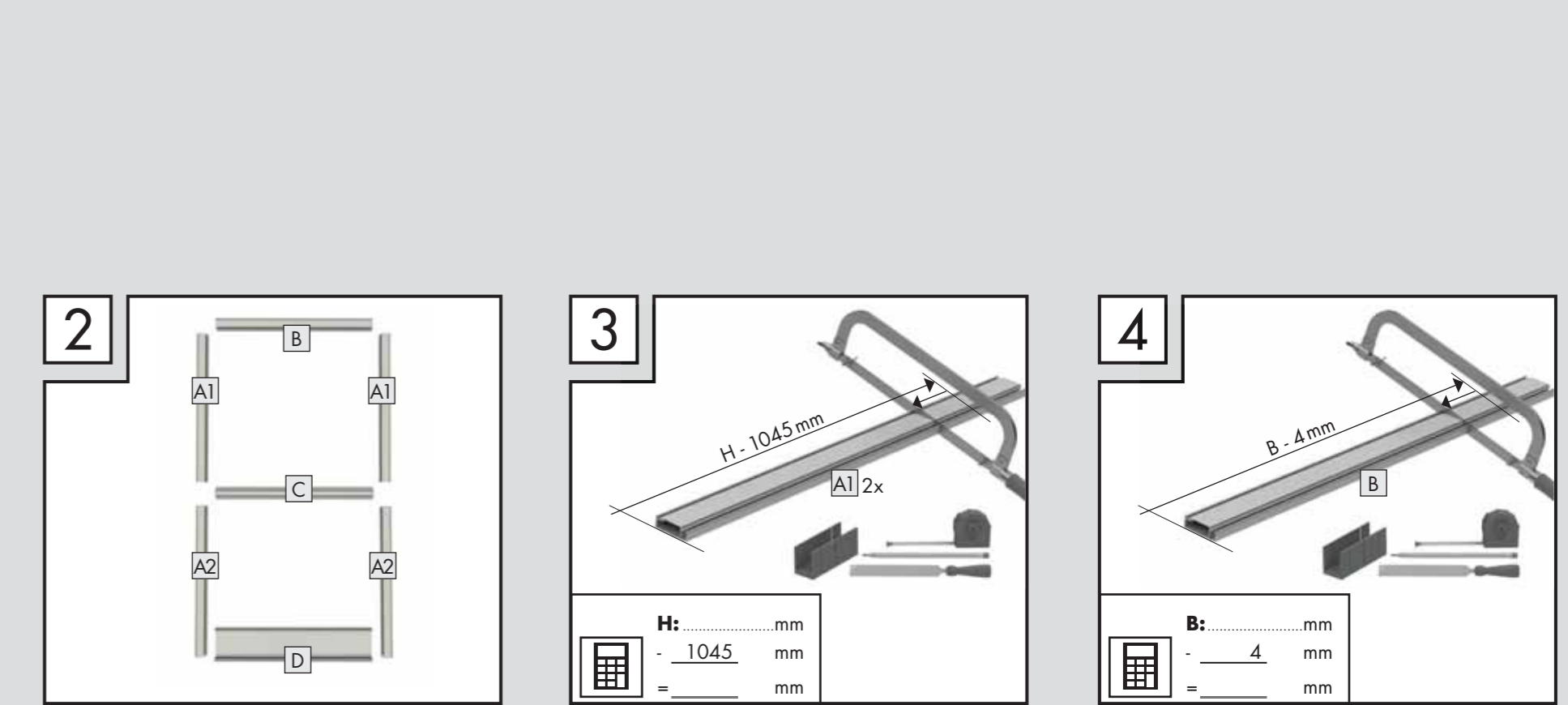
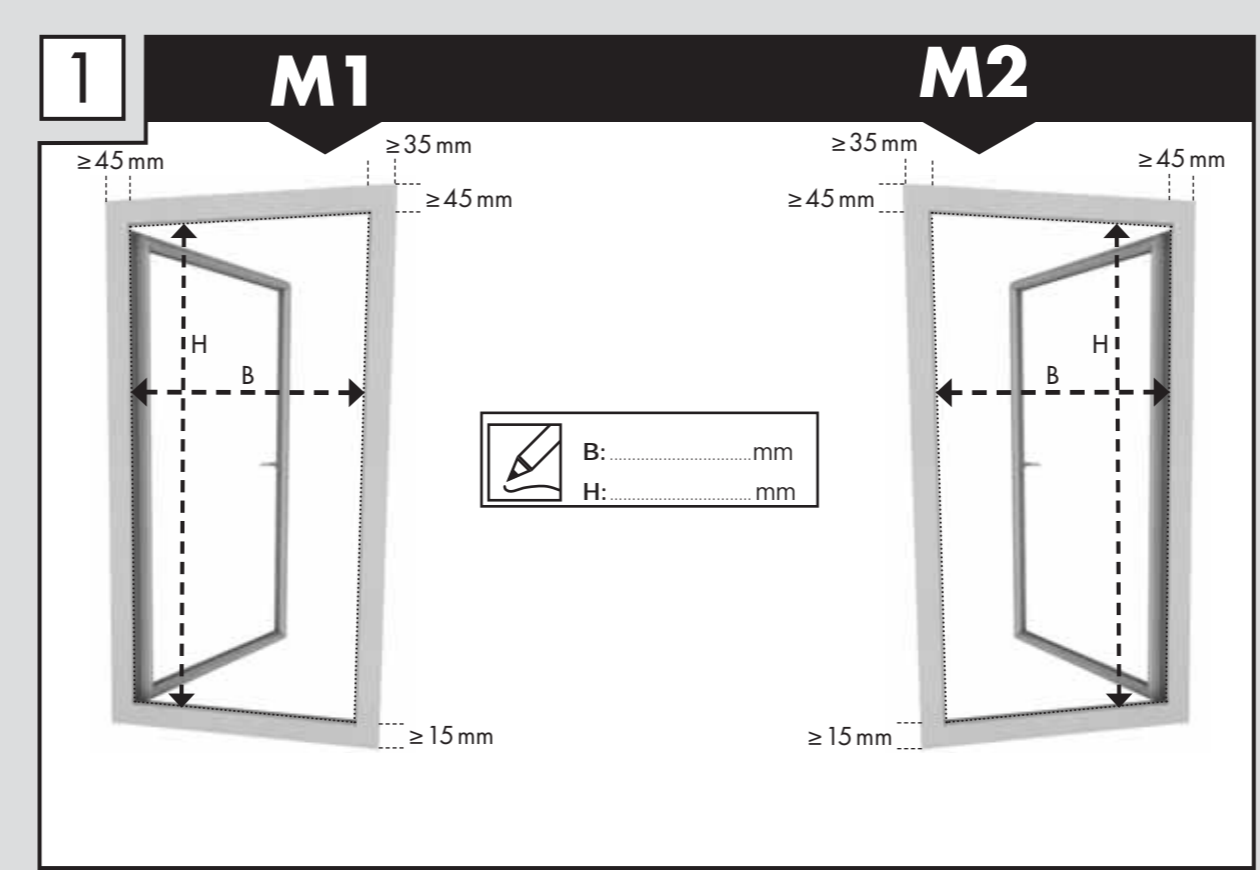
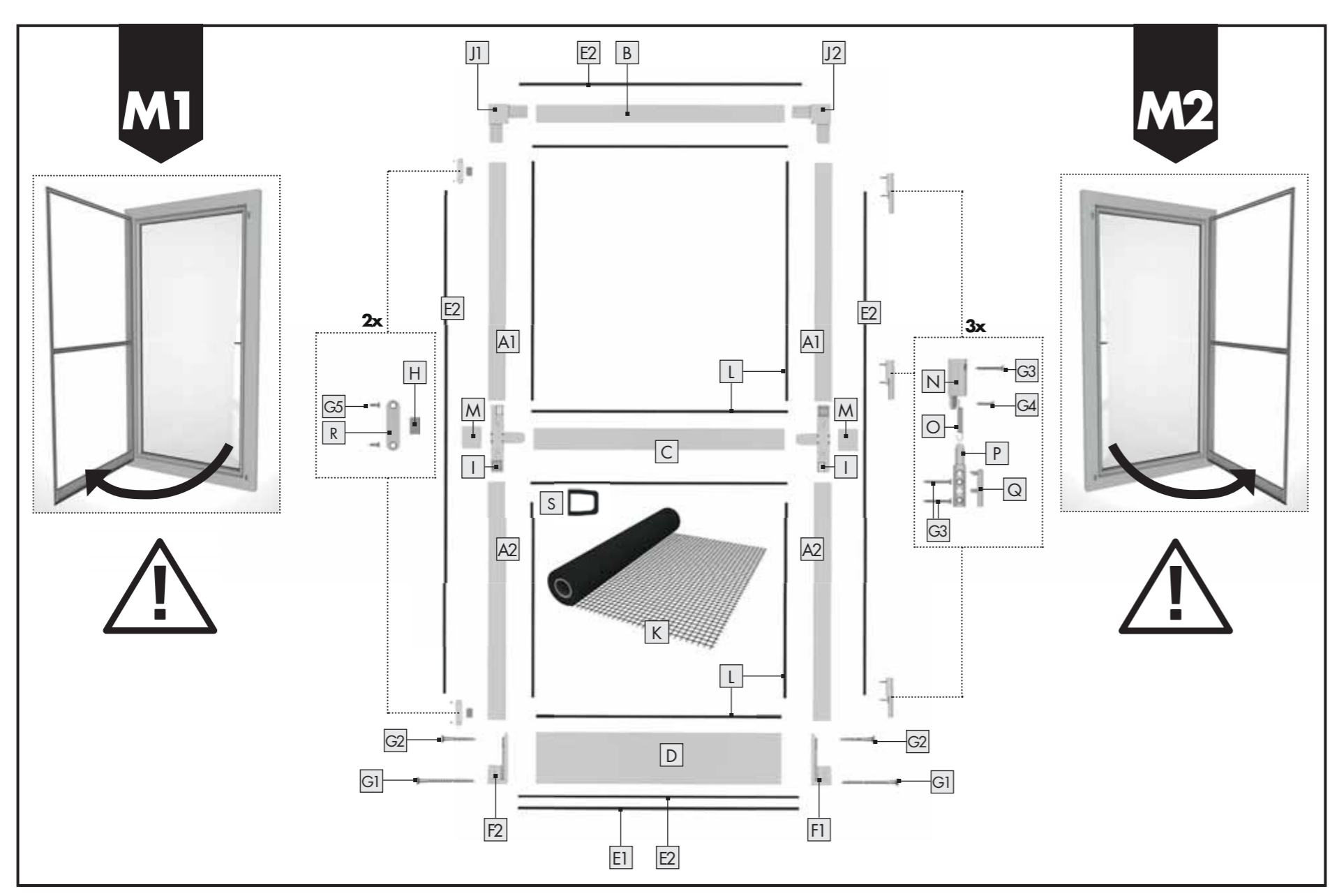

IAN 331013_1907

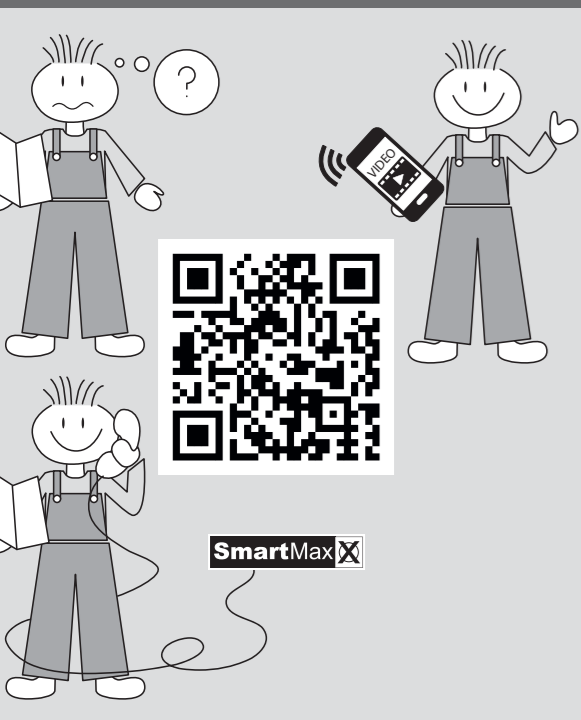

Smartmaxx GmbH
Schulzstraße 2c, DE-85579 Neuburg, GERMANY

